



Combine harvesters

LEXION

8800 8700 7700 7600

CLAAS



True revolutions
start in the heart.



We've listened to you.

And now you can look forward to a combine harvester which has never existed in this form before. A combine harvester which we have redesigned and redeveloped from the ground up in close cooperation with farmers, contractors and operators. Because we know the LEXION means as much to them as it does to us.

The results of this process include the APS SYNFLOW HYBRID, a threshing system which revolutionises the hybrid machine segment and delivers 10% more throughput with the lowest fuel consumption and the best straw quality. And because one revolution leads to others, all the parameters of the new LEXION which make your harvest a success have also been optimised: efficiency, precision, comfort and reliability. Experience the revolution in your fields now!

Enough to make your heart beat faster.
LEXION 8800-7600.



The revolution and its advantages	
Efficiency	6
Precision	8
Convenience	10
Reliability	12
Front attachments	14
Feeder housing	18
Crop flow	20
APS SYNFLOW HYBRID	22
Threshing unit	24
ROTO PLUS	26
Crop cleaning	28
Grain collection	30
Chaff and straw spreading	32
CLAAS POWER SYSTEMS	34
DYNAMIC POWER	36
DYNAMIC COOLING	38
Ground drive and drive concept	40
TERRA TRAC	42
Cab	44
Comfort cab	46
Control concept	48
CEMOS AUTOMATIC	52
Operator assistance systems	54
FLEET VIEW and TELEMATICS	56
Automatic steering systems	58
Maintenance	60
CLAAS Service & Parts	62
Technology in detail	64
Features	66
Technical data	67

Efficiency means success.

APS SYNFLOW HYBRID increases throughput by 10%.
Page 22

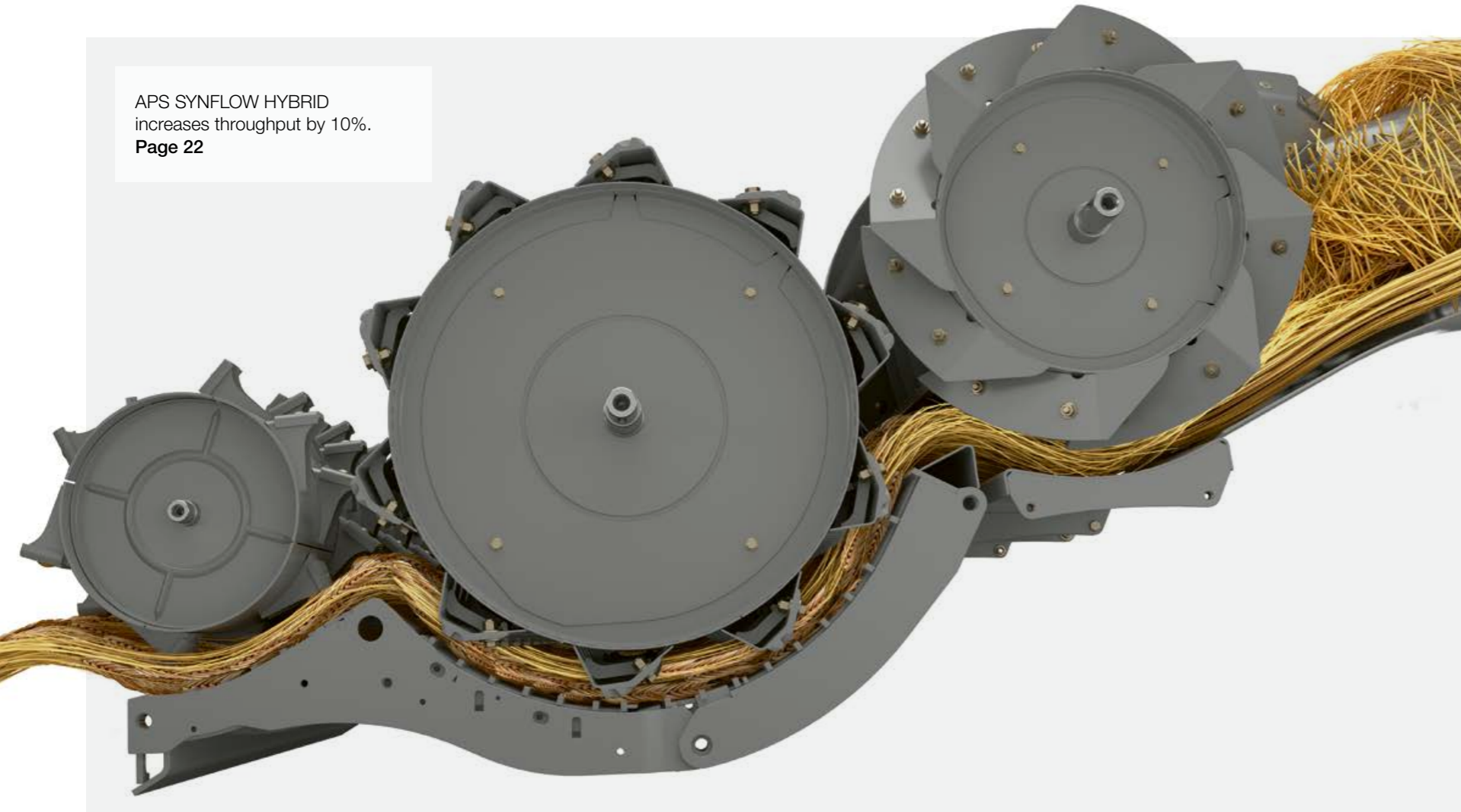

Cutterbars up to 13.8 m allow you to work even more productively.
Page 16



40 km/h gets you there quickly.
Page 40



DYNAMIC POWER for fuel savings of up to 10%.
Page 36



Increase your productivity.

Impressively powerful performance translates into profitable efficiency. The new top-of-the-range LEXION models deliver their top performance precisely when your operators really need it. This means that you save time and money while benefiting from exceptional productivity.

New solutions that boost your efficiency:

- APS SYNFLOW HYBRID threshing system with maximum separation performance
- Straight, fuel-saving crop flow
- Large threshing drum with 755 mm diameter
- Greater threshing concave separation area with reduced contact angle
- Parallel threshing concave adjustment with overload protection
- Grain tank for up to 18,000 l and 180 l/s unloading rate
- DYNAMIC POWER intelligent engine management
- 40 km/h top speed for wheeled machine and TERRA TRAC version
- Cutterbars up to 13.8 m

18,000 l unloaded in 100 s.
Page 30



Discover how much it can do for you.

Precision means profitability.

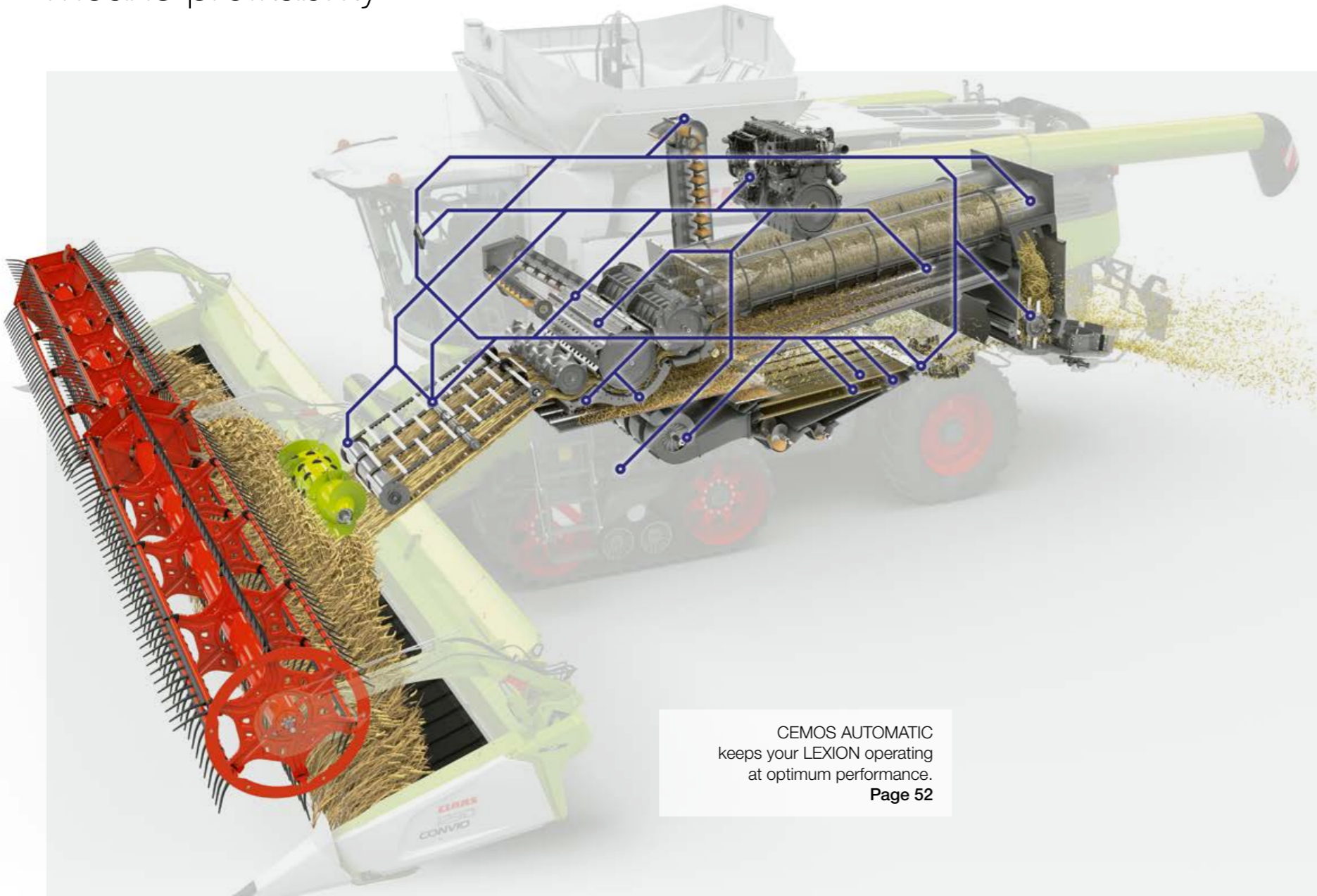

CEMOS AUTOMATIC keeps your LEXION operating at optimum performance. **Page 52**



QUANTIMETER measures your yield precisely. **Page 30**

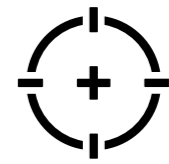

Make use of its intelligence.

To get even more out of your fields, you need a combine harvester that is able to think for itself and think ahead - and to do so precisely. In the new LEXION, self-learning assistance systems, such as CEMOS AUTOMATIC, are working in the background to support the operator during every minute of the harvesting process.



The future is connected. **Page 56**

What's new and improves your precision:

- CEMOS AUTOMATIC continuously optimises threshing unit, cleaning system and crop flow
- CEMOS AUTO THRESHING can now also adjust the threshing concave bar and flap
- CEMOS AUTO SEPARATION optimises secondary separation
- CEMOS AUTO CHOPPING optimises straw management and fuel consumption
- The FIELD SCANNER detects the edge of the crop and recognises tramlines
- QUANTIMETER provides continuous information about the yield
- Remote Service connects your machines and speeds up service support

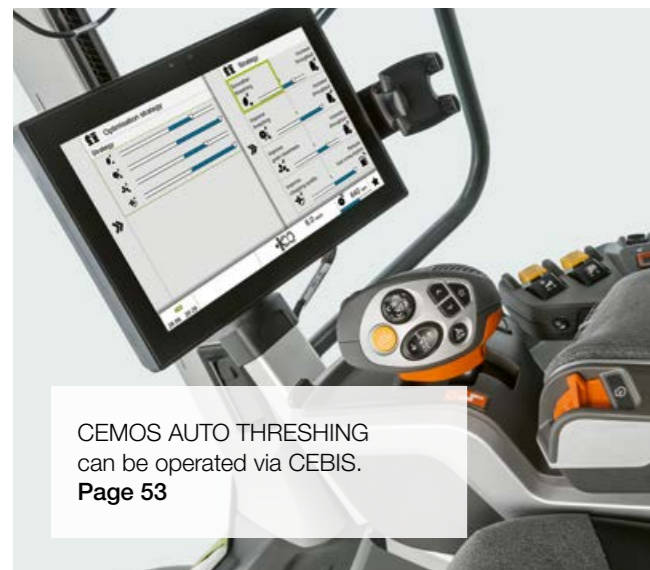

CEMOS AUTO THRESHING can be operated via CEBIS. **Page 53**



FIELD SCANNER gives you a free hand. **Page 58**



CEMOS AUTO CHOPPING was awarded the DLG Silver Medal in 2019. **Page 32**



Discover how precision gives you a greater advantage.

Comfort improves performance.



LEXION comfort cab provides more space and control options. **Page 46**

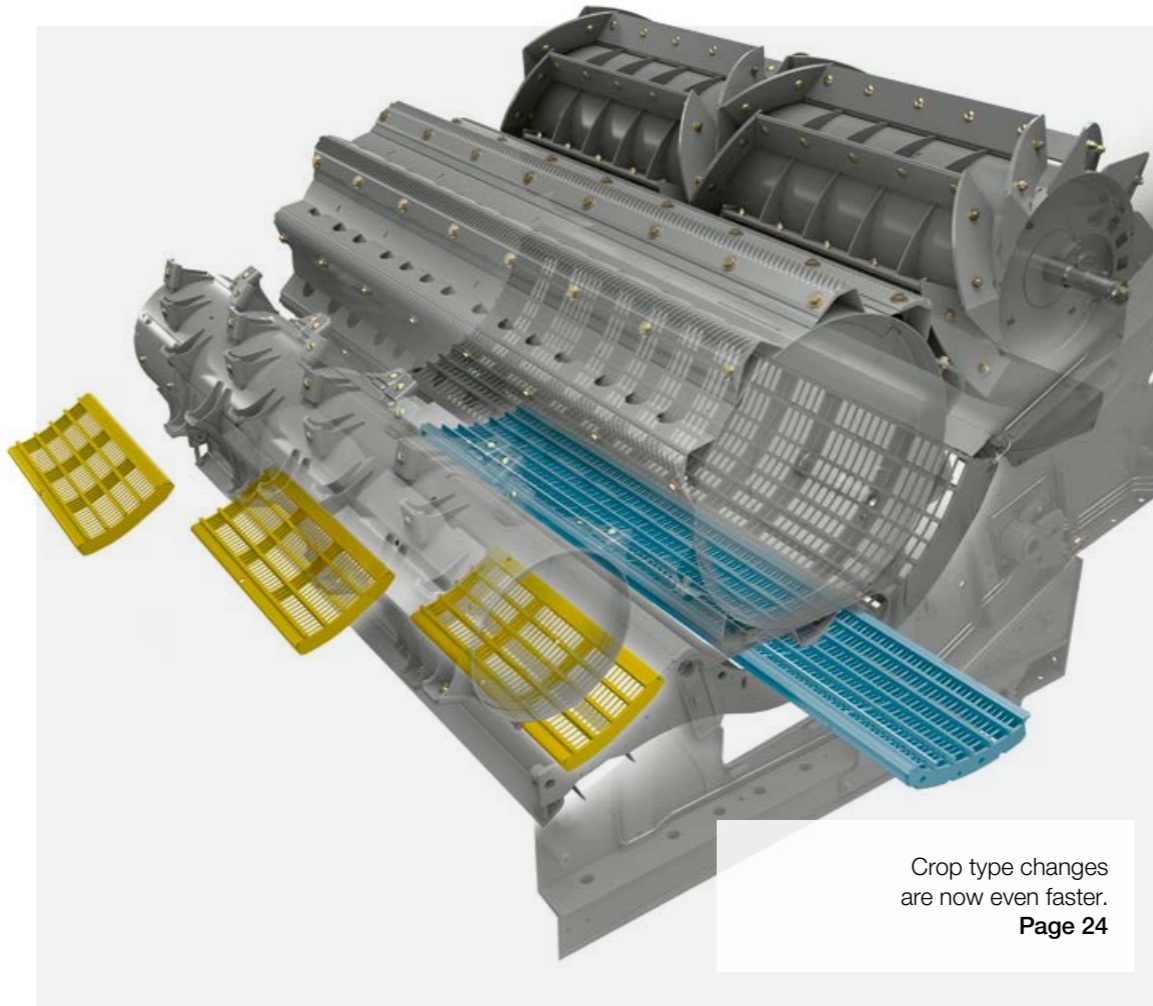

Crop type changes are now even faster. **Page 24**



Harvest for longer.

Few, if any, brands can match CLAAS for comfort features which make your work in the field easier or even do away with some tasks altogether. The new functions of the LEXION offer operators a maximum of individual support so that they remain focused and productive – regardless of how early they start work or how late they stop.

New features for enhanced comfort:

- CEBIS terminal with touchscreen and slide controllers for CEMOS AUTOMATIC
- CEBIS MOBILE with new, intuitive user interface
- Fast crop type changes requiring only a few, simple actions
- Larger grain tank inspection window for fast crop inspection
- Hydraulic adjustment of the pivoting concave bar
- Unloading tube with 105° pivot angle
- Large cool box with active cooling

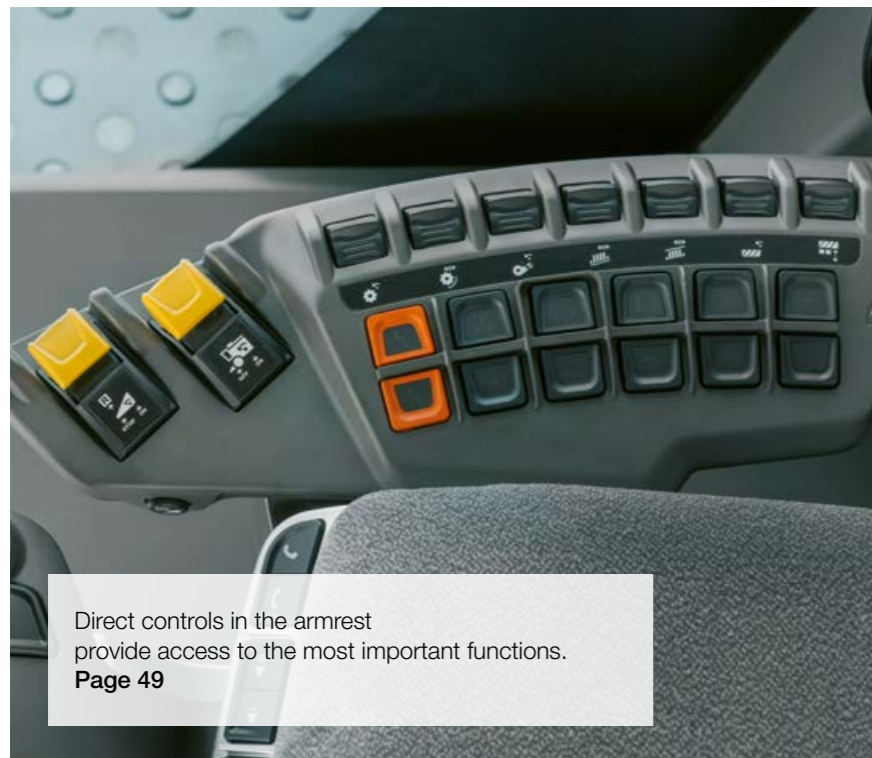

Direct controls in the armrest provide access to the most important functions. **Page 49**



CEBIS touchscreen is as easy to use as your smartphone. **Page 50**



CMOTION multifunction lever can be operated intuitively. **Page 49**



Discover why comfort is an indispensable factor for successful harvesting.

Reassuringly reliable.

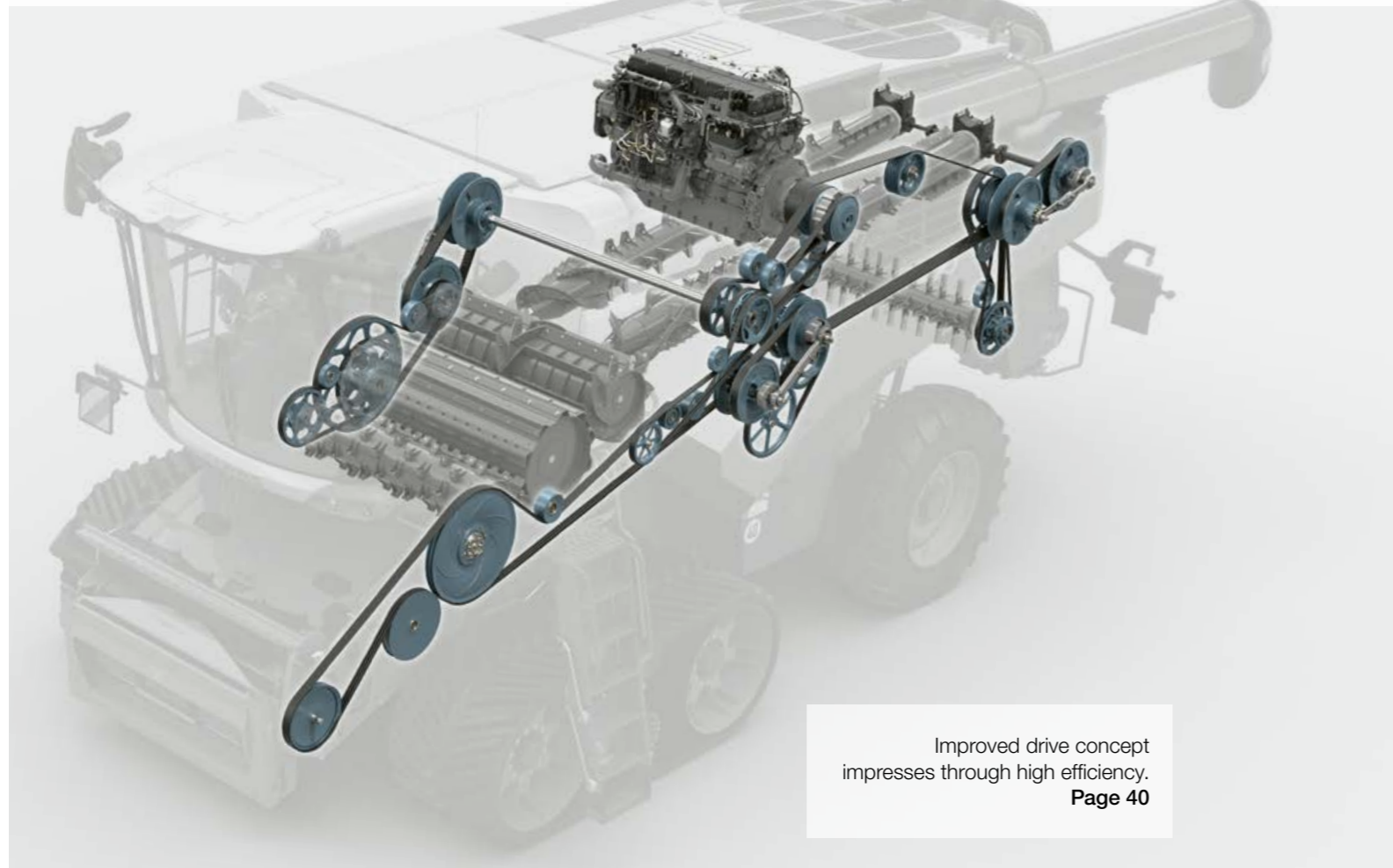

Improved drive concept impresses through high efficiency.
Page 40

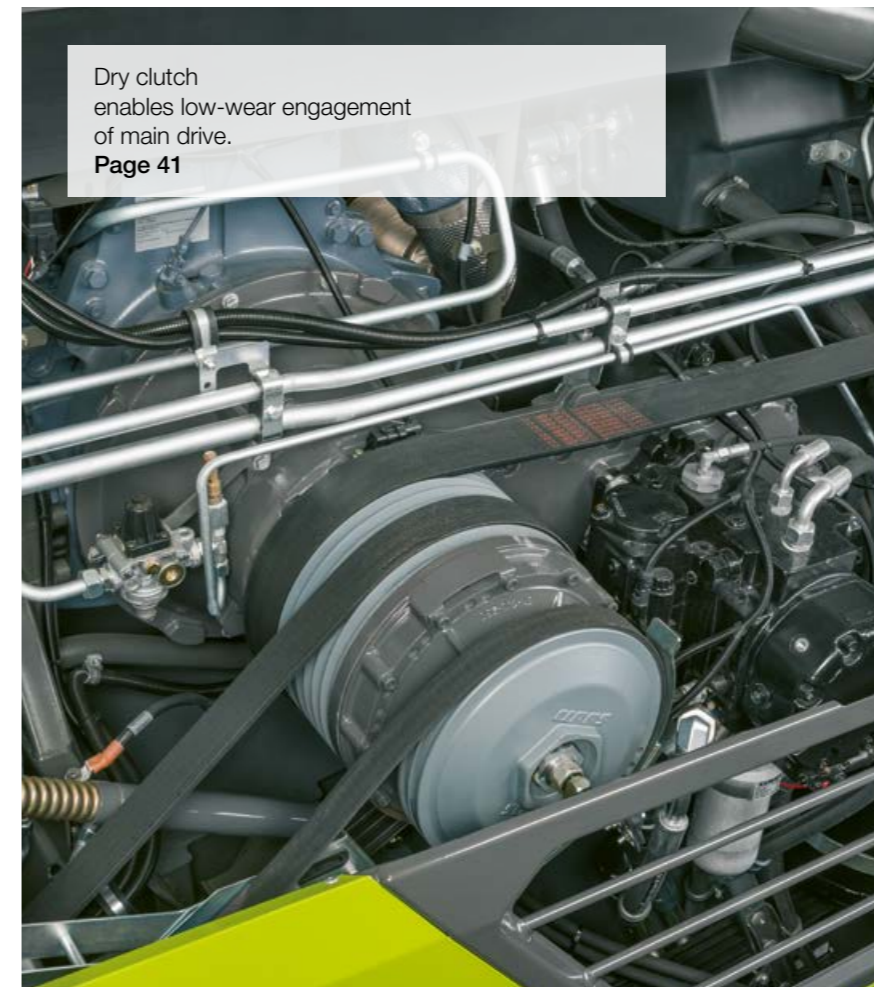

Dry clutch enables low-wear engagement of main drive.
Page 41



You can count on it.

When a revolutionary combine harvester sets new standards for power and performance, it should do the same with regard to endurance and reliability, too. The intelligent drive concept of the LEXION is one of the many factors which keep maintenance requirements low and operating reliability high.

New features which ensure you stay up and running:

- Central lubrication system for all lubrication points, including the variators
- Integrated overload protection to avoid blockages in the threshing unit
- Automatic parking brake for enhanced safety
- More powerful dust extraction with enlarged cross-section
- Belt conveyors for V and HP feeder housing with twice the service life of a feeder chain
- Lowered floor plate in feeder housing for higher throughput



Belt conveyor in feeder housing for smoother running and longer service life.
Page 18

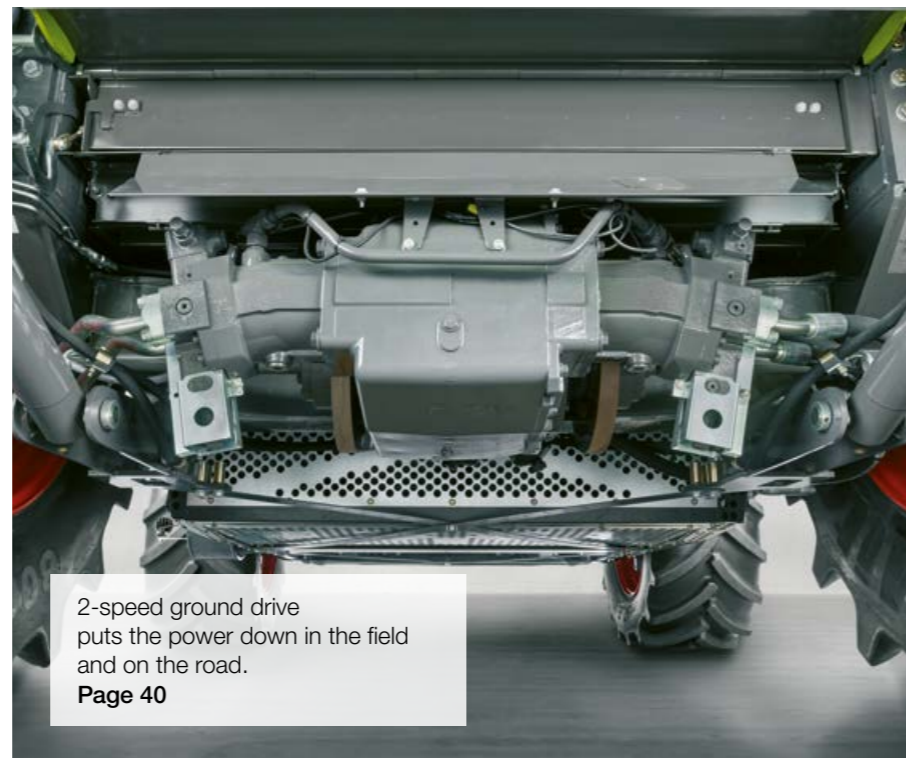

2-speed ground drive puts the power down in the field and on the road.
Page 40



Automatic parking brake for greater safety when machine is stationary.
Page 40



Get to know the features that make the new LEXION a model of reliability.

The revolution starts here.



Cutterbars for all crops.

The harvesting process starts with the front attachment. The right cutterbar ensures optimal cutting performance right from the start and allows your machine to work effectively and at maximum productivity.

Whether you are harvesting grain, such as wheat, rye, barley, oats and triticale or rapeseed, maize, sunflowers, rice, soya, flax, beans, lentils, millet, grass seed or clover seed, CLAAS front attachments allow you to make full use of the performance potential of your LEXION.

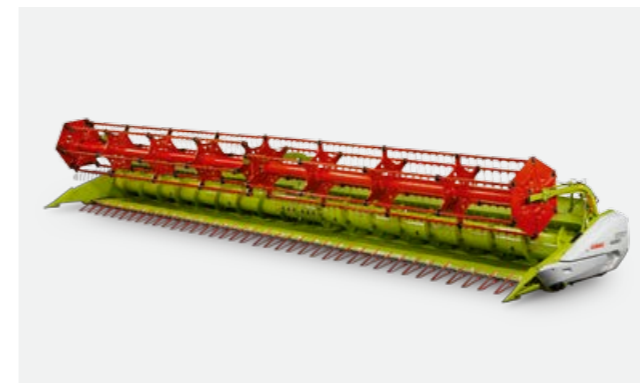

VARIO



CERIO



CONVIO / CONVIO FLEX

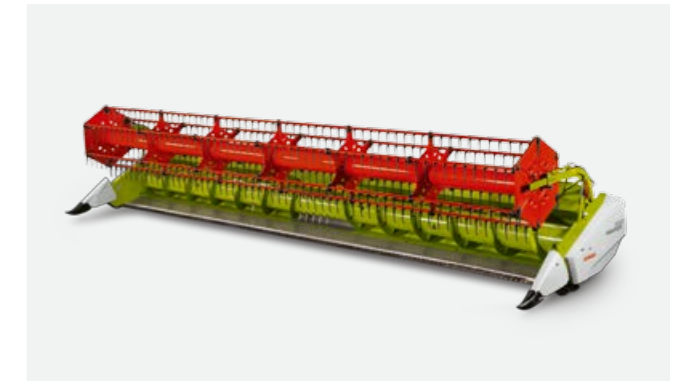

MAXFLEX



CORIO / CORIO CONSPEED



SUNSPEED



SWATH UP

Choose your front attachment.

Regardless of where in the world you are harvesting, CLAAS has the right cutterbar for every threshable crop.



combine-front-attachments.claas.com

On top of the job right from the start.

The LEXION detects its front attachments.

Automatic front attachment detection reduces your operators' workload substantially before harvesting even starts and also helps to prepare the combine harvester more quickly. In order to allow the LEXION to adjust its key parameters to the new front attachment, the latter supplies the combine harvester with the following information:

- Cutterbar type
- working width
- Number of sections
- Reel position
- Parking position for reel and VARIO cutterbar table
- AUTO CONTOUR set values for working height and hectare counter
- Operating hours meter and maintenance counter



Front attachment brake and reverser to enhance safety.

The front attachment brake offers you effective protection against foreign objects. In an emergency, the front attachment can be stopped immediately via the multifunction control lever. Blockages can be overcome with gentle reversing with high starting torque. The direction of rotation of the reel also changes automatically. The reverser is operated from the comfort of the cab.



Multicoupler saves time.

The central coupling for all hydraulic and electronic connections saves you valuable time when fitting and removing the cutterbar. The high-quality, wear-free multicoupler is suitable for all models of front attachment. It is located on the left-hand side near the front attachment lock. No connections need to be made on the right-hand side.



AUTO CONTOUR - precise cutterbar control.

AUTO CONTOUR adjusts every cutterbar to the terrain precisely by reliably compensating for all ground irregularities parallel and transverse to the direction of travel. Sensor bands under the cutterbar are deflected by the undulations and trigger the actuation of the corresponding cutterbar ram. The desired cutting height is programmed via CEBIS.

AUTO CONTOUR

- Allows the front attachment to work smoothly and provides gentle damping
- Reduces the operators' workload considerably when wide cutterbars are used
- Is ideal at night, in lodged crops, on side slopes and on stony ground
- Increases output and makes the LEXION even more cost-effective

New features that reduce your workload:

- Automatic front attachment detection means that the LEXION is ready for action even faster
- Fast response of front attachment brake protects the threshing unit from foreign objects
- Powerful reversing action of feeder housing, intake auger and reel keeps downtime to a minimum
- Central multicoupler for all connections saves time when fitting and removing cutterbar
- AUTO CONTOUR adjusts every cutterbar to the terrain precisely

The feeder housing takes things as they come.

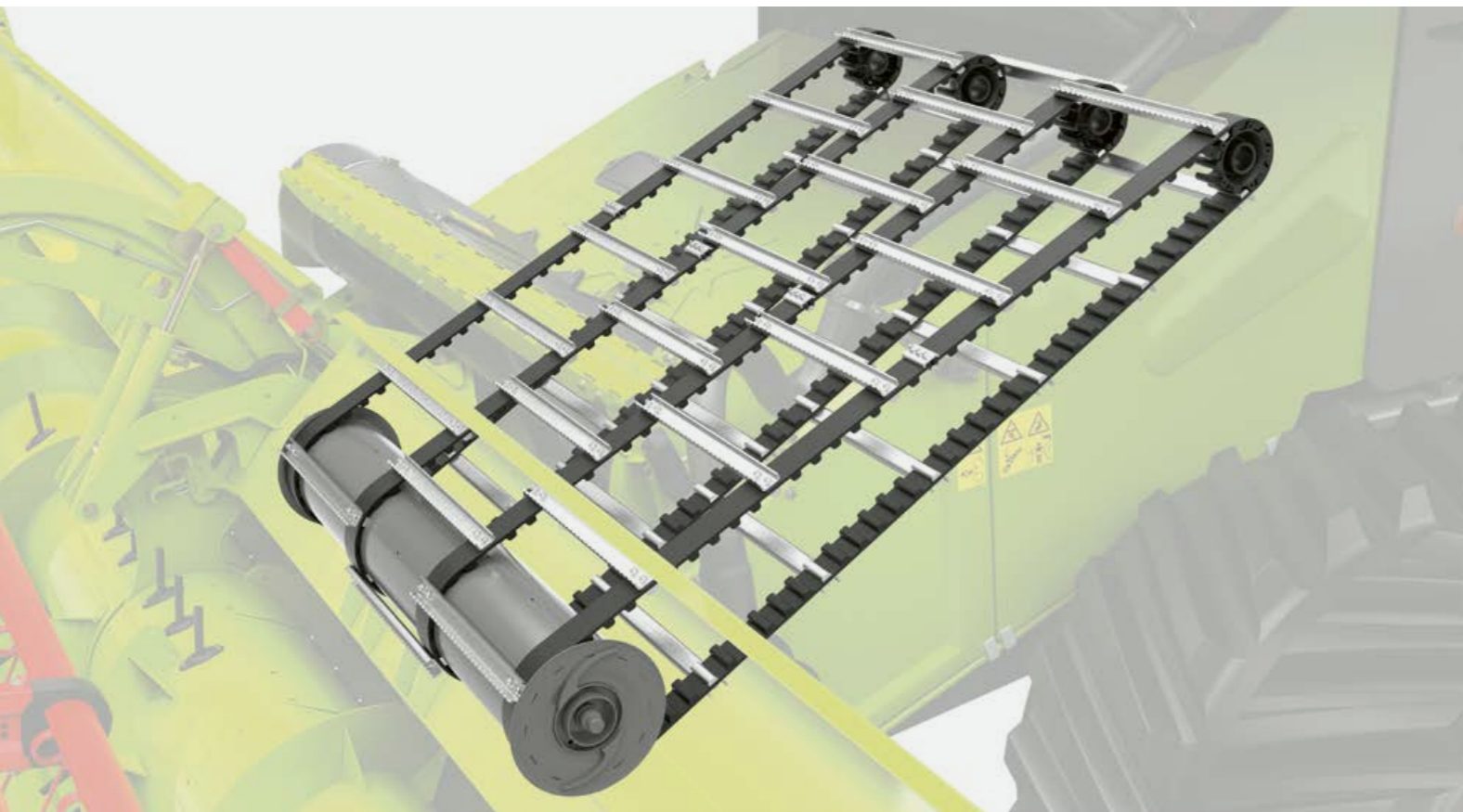

Belt conveyors with twice the service life.

As an option, every feeder housing of the new LEXION is available with belt conveyors linking the reinforced feeder slats. You benefit from them every minute the machine is in use, as the extremely robust belt conveyors run more smoothly and quietly than conventional chain conveyors.

Feeder housing without support roller.

The redesigned feeder housing does not require a central support roller. As a result, it is less susceptible to disruption by foreign objects in the crop flow.

VARIO with automated cutterbar control.

The VARIO cutterbar with automated reel control allows you to save the reel levelling and table position settings in CEBIS. The values are recalled automatically as soon as you activate the automatic cutterbar control via the multifunction lever.

New features that make the feeder so effective:

- Belt conveyors for V and HP feeder housing are more robust and require less maintenance than chains
- Belt conveyors provide stability and operating reliability
- Dust extraction with enlarged cross-section delivers even greater cleaning performance
- The additional fan on the feeder housing prevents dust deposits
- The height of the feed roller can be adjusted in the HP feeder housing without tools
- A lowered floor plate enables even higher throughputs



The V feeder housing.

The V feeder housing allows you to carry out fast, mechanical adjustment of the cutting angle, even with the front attachment fitted. The height of the guide roller can be adjusted easily. You can order the V feeder housing ex factory with chain or belt conveyors as well as with an open or closed guide roller.

The advantage for you:

By adjusting the cutting angle, you can harvest lodged crops, soybeans and grass more easily and with reduced losses as the tendency for the crop to pile up is reduced.



HP feeder housing.

Using the multifunction lever in the cab, you can perform continuous hydraulic adjustment of the cutting angle of the HP feeder housing from -8° to $+11^\circ$ – when running at full speed with the front attachment fitted. You can store a separate cutting angle for each of four cutting heights in CEBIS.

The advantage for you:

Easy cutting angle adjustment in response to changing crops (lodged crops), threshing crops (soybeans, grass) or terrain conditions (slopes, undulating terrain).



Standard feeder housing.

The standard feeder housing with a manual tensioning system is available with chain or belt conveyors as well as with an open or closed guide roller. The simplified height adjustment procedure for the guide roller enables a fast changeover from maize to small grains.

The advantage for you:

Can be used universally for all cutterbars with a working width of up to 12.30 m or for maize pickers up to 12 rows.

Revolution: when peak performance becomes the new normal.

Revolutionary thanks to your input.

Feeder housing, APS SYNFLOW threshing unit, ROTO PLUS secondary separation, straw management – in theory, there are many parameters which can be improved to accelerate the crop flow. And in practice, too. Working in close cooperation with our customers, we have rethought all the systems in the LEXION from the ground up. On top of this, we have provided the operators with assistance systems so that they can run this machine permanently at its performance limits.



Crop flow acceleration to 20 m/s makes for outstanding throughput.



The new heart has a name: APS SYNFLOW HYBRID.

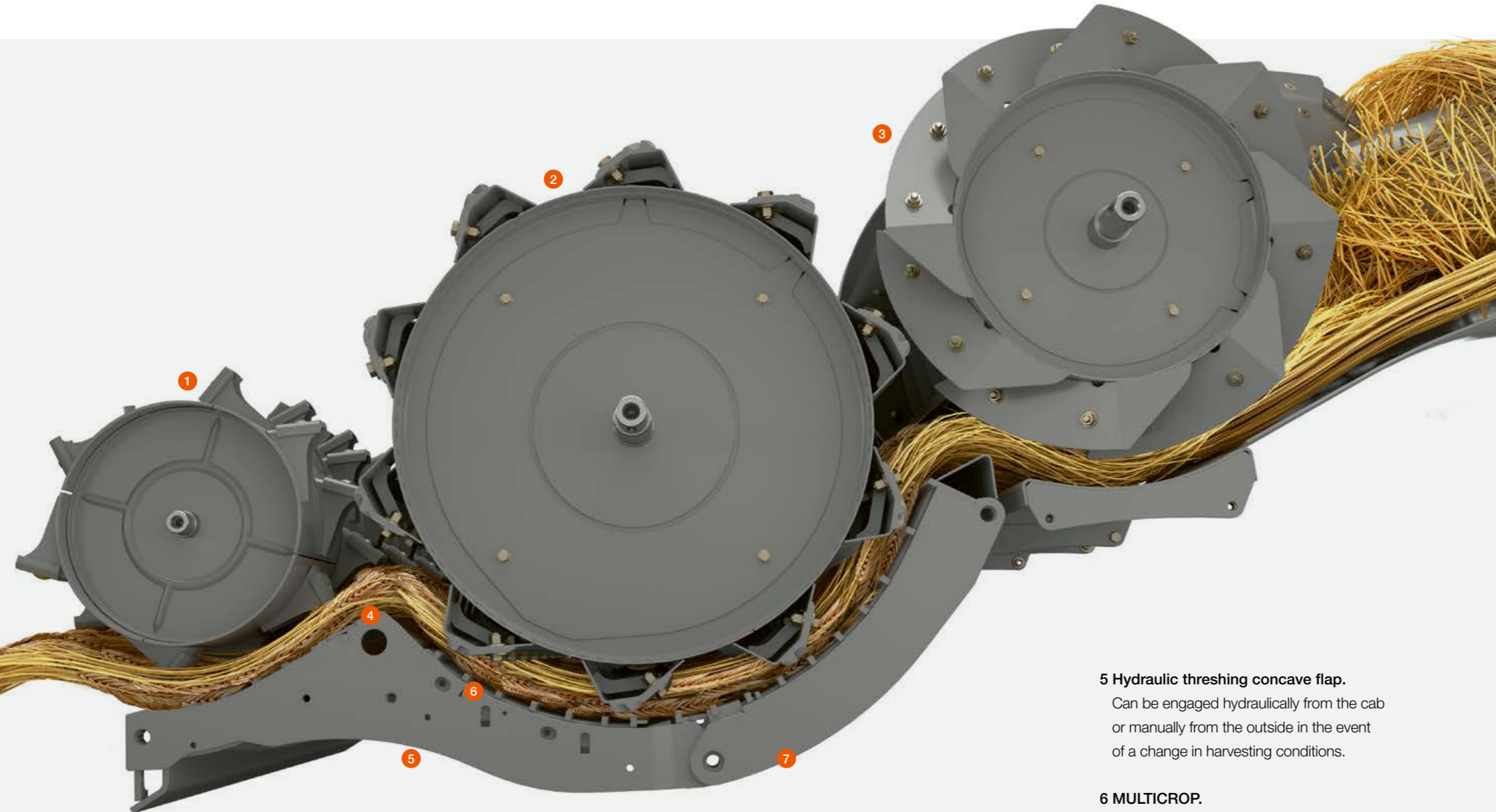

1 Maximum separation performance.
Smooth acceleration of crop flow to as much as 20 m/s across all concave areas.

2 755 mm threshing drum.
Threshing drum enlarged by 26% for optimal crop flow.

3 600 mm feeder drum.
Blockage-free feeding of the harvested material to the rotors.

4 Pivoting concave bar.
Can be engaged hydraulically from the cab via CEBIS for fast crop-type changes.

5 Hydraulic threshing concave flap.
Can be engaged hydraulically from the cab or manually from the outside in the event of a change in harvesting conditions.

6 MULTICROP.
Short changeover times and various combination options make it easier for you to change crop types.

7 Synchronised adjustment.
The preconcave and threshing concave are adjusted in parallel. The drum speed changes are synchronised.



The straighter the crop flow, the more efficient your harvest.

Straight-line crop flow saves fuel.

The 450 mm accelerator drum in the APS SYNFLOW HYBRID starts an extremely efficient threshing process which allows you to achieve outstanding throughput rates. It accelerates the crop flow smoothly to as much as 20 m/s. In so doing, it generates a high centrifugal force which enables maximum separation performance across all concave areas.

Large drum diameters and small contact angles enable particularly flat transitions between the threshing and feeder drums as well as the rotors. This means that there is a straight, fuel-saving crop flow through the combine harvester. What's more, there are no unnecessary changes of speed or direction of flow. This makes for gentle straw handling and saves fuel.

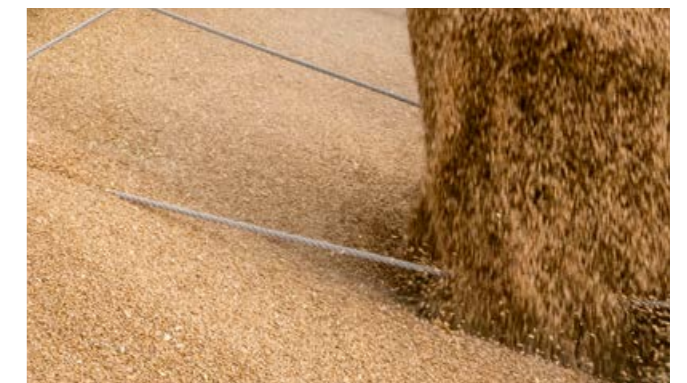

APS SYNFLOW threshes every crop.

Increase throughput by 10%.

We have revolutionised the threshing system of the new LEXION from the ground up. The combination of the tangential APS SYNFLOW threshing unit and the axial ROTO PLUS secondary separation makes the APS SYNFLOW HYBRID threshing unit the trendsetter for its class. You can look forward to 10% higher throughput during your next harvest – with extremely low fuel consumption and top straw quality.

Easy actuation of preconcave flap and threshing concave flap.

In order to react to a change in crop type or for flexible adjustment of the friction path in the threshing and separation sections, the operator can engage the preconcave flap and the threshing concave flap manually from outside. The threshing concave flap is also available with optional hydraulic adjustment. When this option is specified, it can be operated conveniently from the cab and is integrated in CEMOS AUTO THRESHING.

Synchronised speed adjustment.

The threshing drum speed can be matched easily to all conditions and crop types. It can be adjusted – independently of ROTO PLUS – in CEBIS to any setting between 330 and 930 rpm. The speeds of the accelerator drum, the threshing drum and the feeder drum change in synchronisation.

Perfect adjustment of threshing unit.

In order to align your LEXION optimally with your business and your preferred crops, six threshing unit versions and three rework kits are available to match the profile of the areas you work. The range allows you to find the ideal threshing unit for rice, maize, beans and grains with high or low yields.



Crop type change
in 60 seconds.

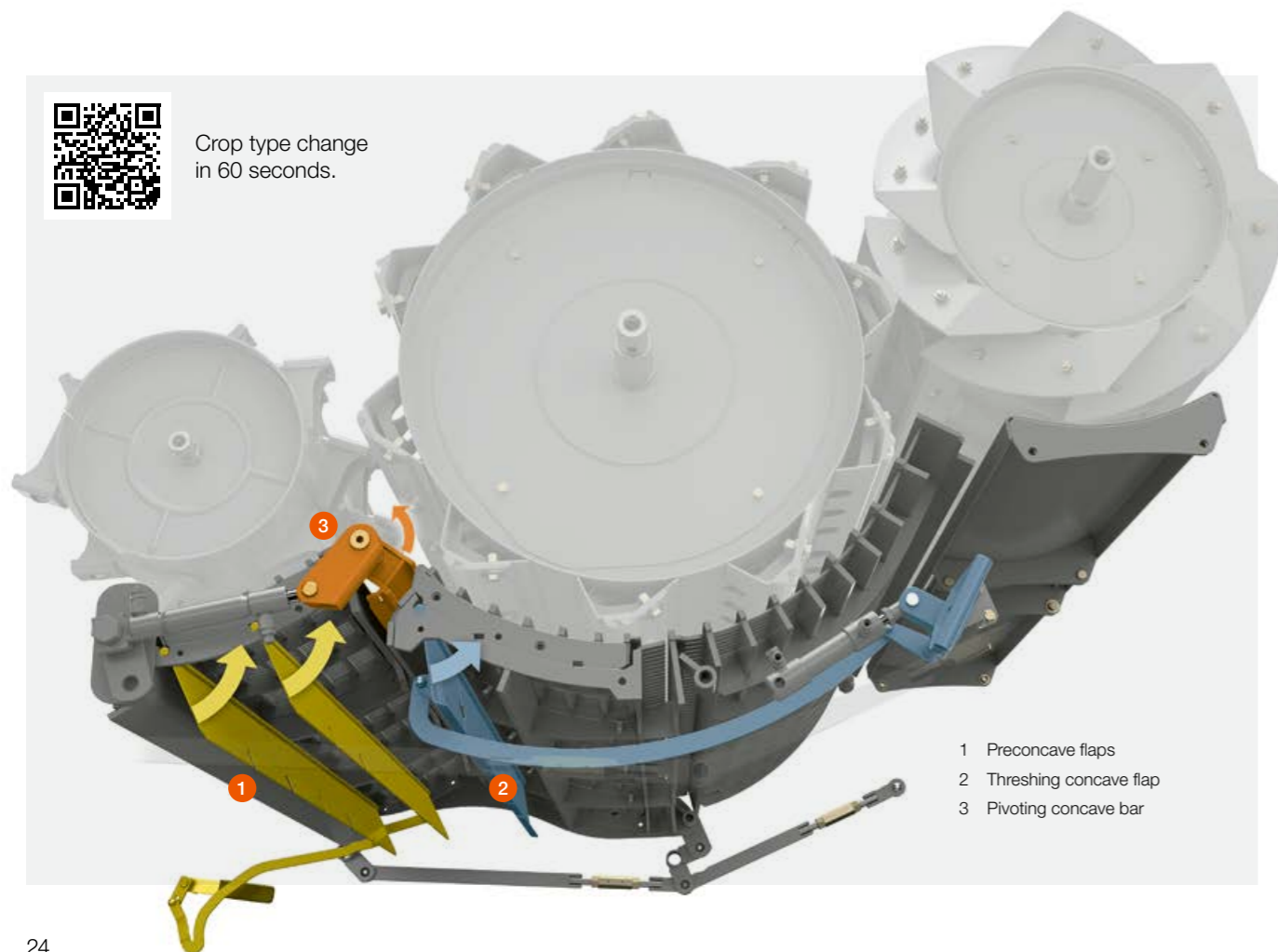

- 1 Preconcave flaps
- 2 Threshing concave flap
- 3 Pivoting concave bar

Parallel adjustment of threshing concave.

CEBIS allows infinitely variable hydraulic adjustment of the position of the threshing concave. As this involves the parallel and synchronised adjustment of the preconcave, threshing concave and separator concave, you can be certain that the entire crop flow will run evenly while handling the straw gently. Integrated overload protection prevents blockages and protects the threshing unit from damage.

Hydraulically pivoting threshing concave bar.

For clean threshing under all conditions, including when deawning or decortication is difficult, the threshing concave bar can be pivoted hydraulically via CEBIS. Like the hydraulic actuation of the threshing concave flap, this comfort feature is integrated in CEMOS AUTO THRESHING.

Change concave segments quickly.

Changeover times from one crop type to another are getting ever shorter. When a changeover is carried out, the main components of the threshing concave remain in the machine. You can quickly change the preconcave segments through the stone trap simply by pulling the threshing concave segment out to the side. The numerous combination options are the key to the unique MULTICROP capability of the LEXION.

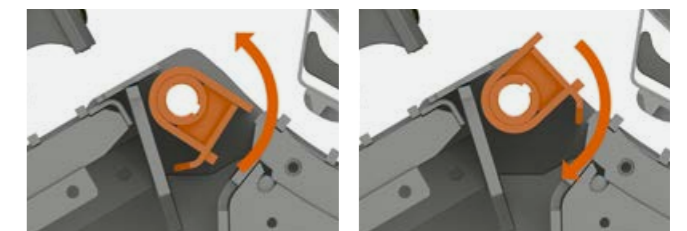

ROTO PLUS

makes the most of your crop.

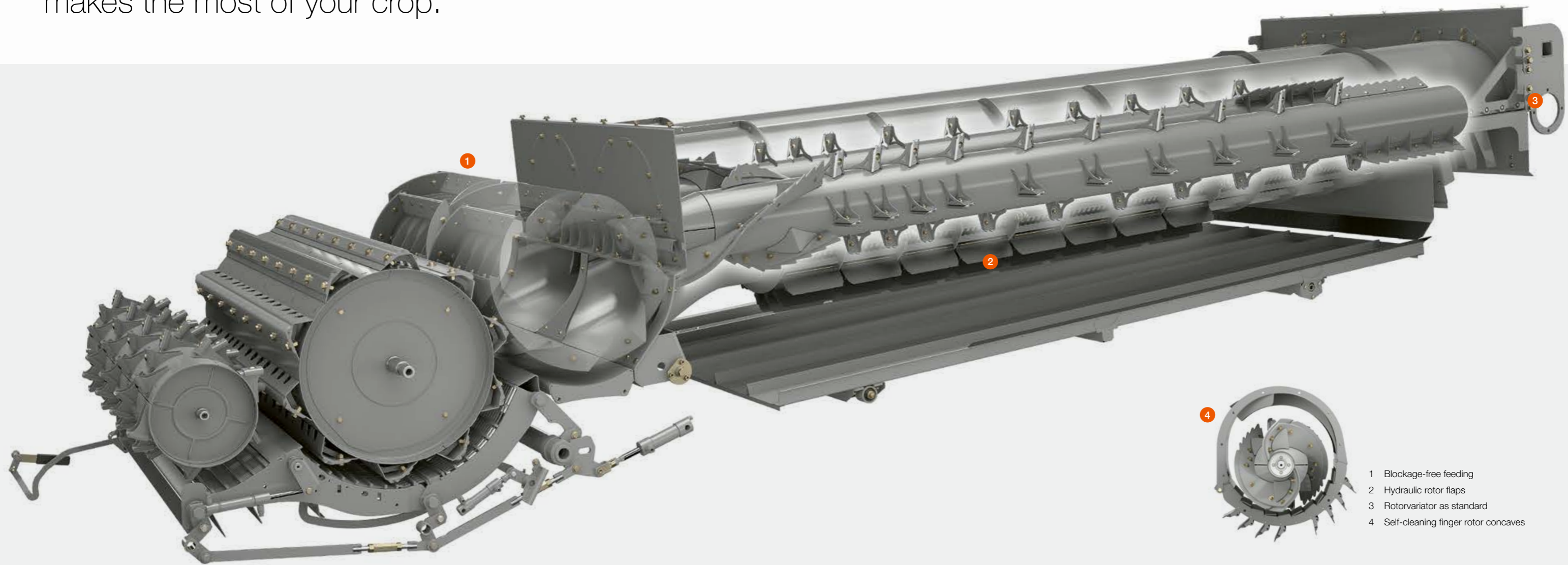

- 1 Blockage-free feeding
- 2 Hydraulic rotor flaps
- 3 Rotor variator as standard
- 4 Self-cleaning finger rotor concaves

Every grain counts.

The eccentrically mounted ROTO PLUS high-performance rotors generate tremendous centrifugal force to separate the remaining grains from the straw. With a diameter of 445 mm and a length of 4,200 mm each, they provide a huge separation area.

The mixture of grain, straw and chaff first reaches the preparation floor via the separate returns pan before passing over the straw walker steps to the sieve pan. This significantly reduces the load on the sieve pan.

New features that optimise your secondary separation:

- A 57% larger feeder drum ensures that no blockages occur as the harvested material is transferred to the rotors
- Up to four divided hydraulic rotor flaps are fitted ex factory and prepared for incline-dependent control
- The finger rotor concaves are self-cleaning and wear-resistant
- Together, all these features increase the separation performance, even under difficult harvesting conditions

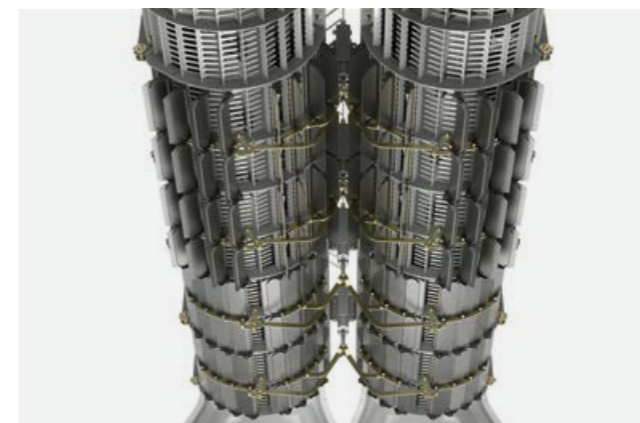

Hydraulic rotor flap adjustment.

You can adjust the secondary separation area as required in CEBIS. Hydraulic rotor flaps close up to four rotor segments while the machine is on the move.



Powerful 4D cleaning system.

The cleaning performance remains stable, even when operating in undulating terrain: the 4D cleaning system adjusts the position of the rotor flaps automatically and acts in the background to support the operator.

Clean grain is worth real money.

JET STREAM cleans more intensively.

With the JET STREAM cleaning system, a dual-ventilated straw walker step provides intensive pre-cleaning.

- High standard of cleaning through extremely powerful cleaning system
- High performance from a compact system with a low level of sieve loading

In addition to larger sieve areas and a bigger grain auger, there are three key differences compared with the standard cleaning system:

- A 56% higher first step
- A long airflow equalisation duct with the airflow oriented upwards
- An additional turbine fan unit

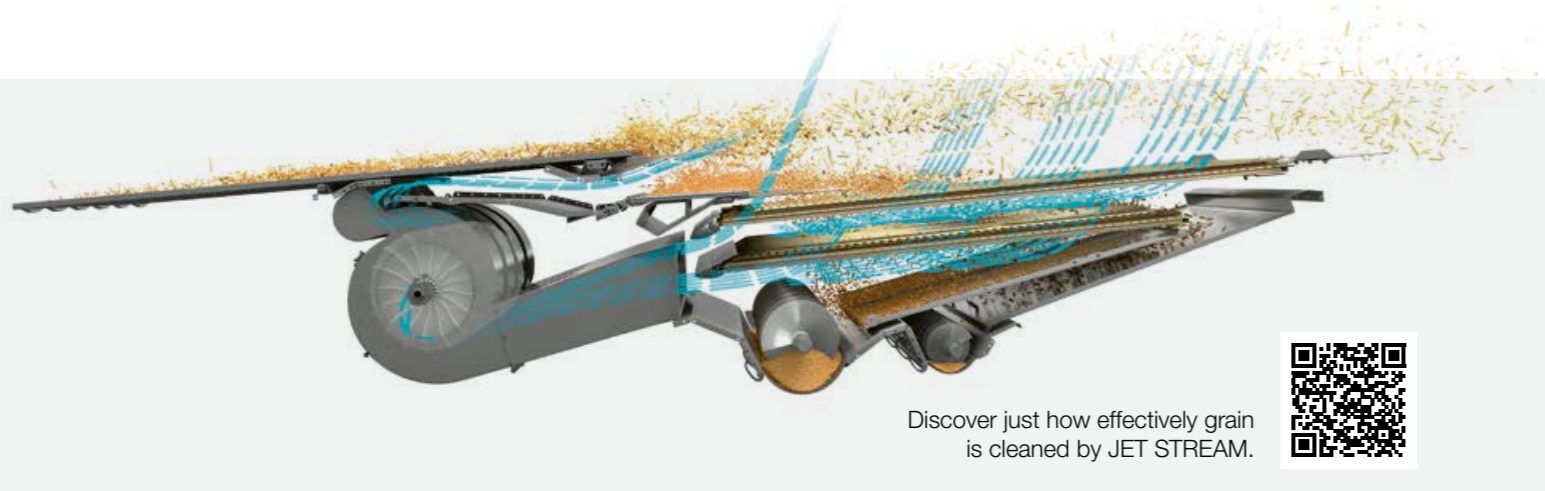

Discover just how effectively grain is cleaned by JET STREAM.

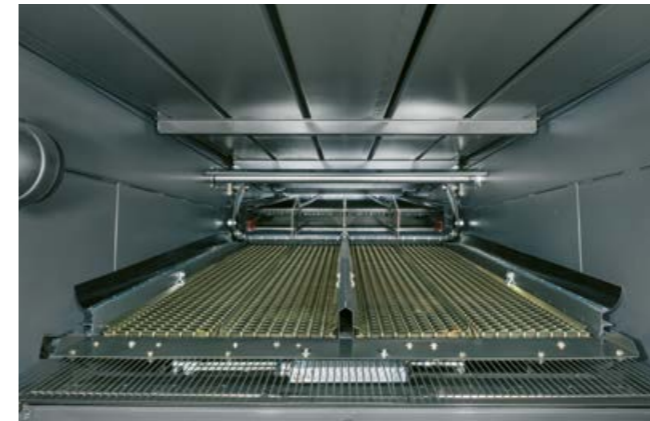

The 3D cleaning system makes a difference on slopes.

Using active transverse control of the upper sieve, the 3D cleaning system provides dynamic compensation for side slopes of up to 20%. The material is distributed evenly across the sieves, the cleaning performance remains absolutely stable. In combination with AUTO CONTOUR, this maintenance-free system forms an ideal hillside package.

The preparation floor reduces the load on the upper sieve.

The crop is pre-sorted into grains (bottom) and chaff and broken straw (top) on the preparation floor, thereby reducing the load on the upper sieve and increasing the cleaning capacity. The individual plastic elements can be easily pulled out towards the front through the stone trap for cleaning.

The GRAINMETER analyses the returns.

Using two sensors at the end of the lower sieve, the GRAINMETER registers the grains in the returns. Measurement of the returns by means of the photo cell makes it possible to calculate the proportion of grains to the total volume in the returns. The sensitivity is set in CEBIS where you can also read off the data conveniently and optimise the combine settings, if necessary.

The returns flow evenly into the threshing unit.

The returns are deposited on the accelerator drum, spread out and fed evenly to the threshing drum. At 15 l/s, the feed rate of the returns is a perfect match for the increased throughput of the new LEXION.

The returns volume is measured electronically.

A photo cell on the returns elevator measures the entire volume of material and reduces the operator's workload by providing a continuous display of the returns figure in CEBIS. The cab is designed to allow the illuminated returns to be viewed directly from the operator's seat, thereby allowing conclusions to be drawn about the optimal machine settings.



With its combination of hydraulic and mechanical elements, the fully automatic 3D cleaning system is able to dispense completely with electronic sensors.

Collect your grain quickly and safely.

Up to 18,000 l of grain in the tank.

With a volume of up to 18,000 litres, the grain tank has a capacity to match the increased throughput of the LEXION. Buttons on the armrest control the automatic opening and closing of the grain tank. Additional steps and handrails make access even safer.



Grain tank unloading at up to 180 l/s.

At 180 l/s you can unload the large grain tank of the LEXION in record time. The rate can be reduced from 180 l/s to 90 l/s. If necessary, you can stop the process immediately or turn off the augers gradually in order to completely empty the grain tank unloading tube first.

- Reliable filling of the transport vehicles
- No losses during unloading

Precise yield measurement.

The new measuring principle used by the QUANTIMETER no longer requires the hectolitre weight for calibration. It determines the yield quickly and precisely by means of a baffle plate with an integrated measuring cell at the ejection point of the grain elevator. This system can be calibrated from the cab.



A simple explanation of the new QUANTIMETER measuring principle.



- 1 Grain elevator
- 2 GRAIN QUALITY CAMERA
- 3 QUANTIMETER yield measurement
- 4 Moisture measurement

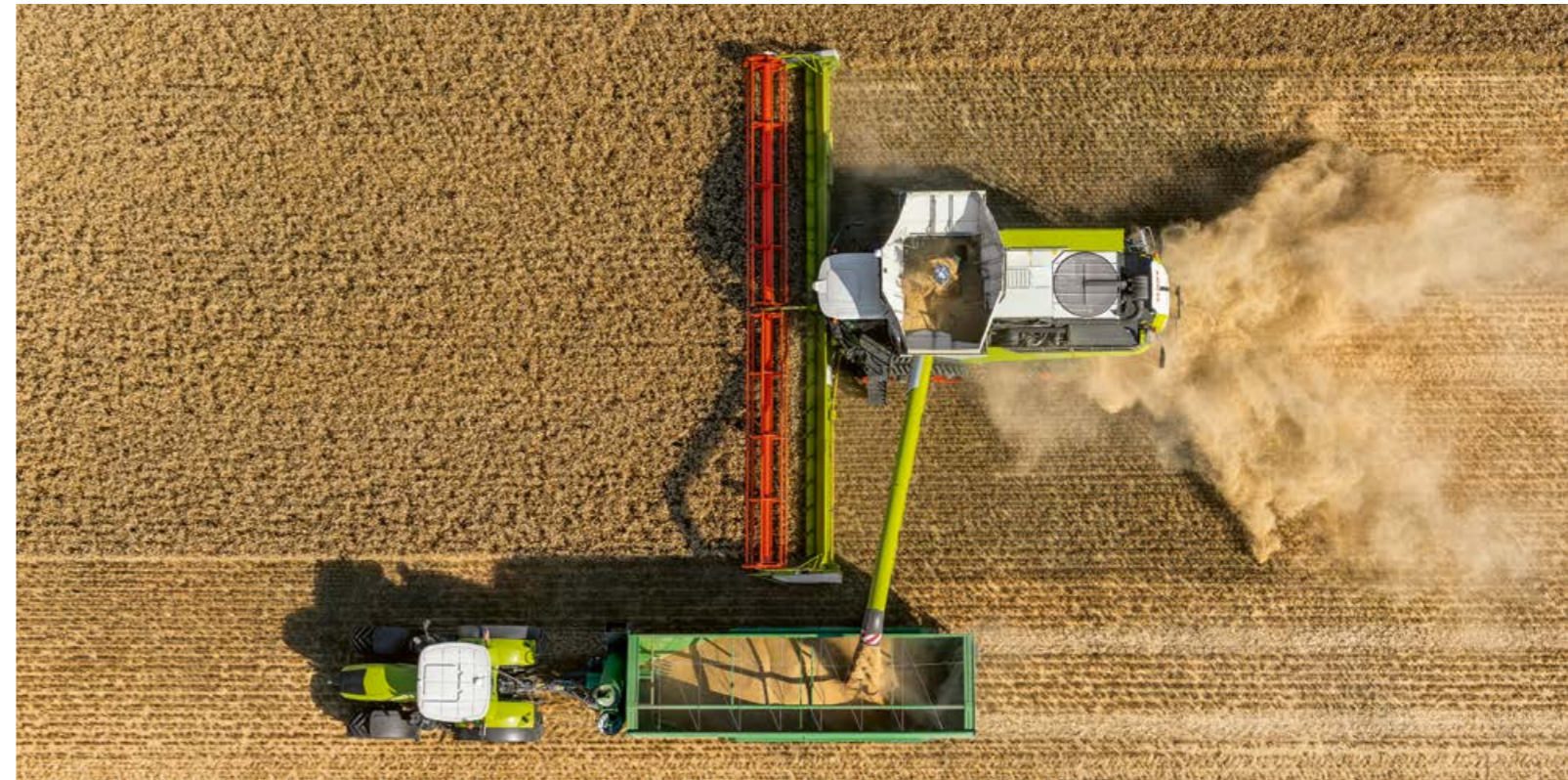

Grain tank unloading tube with 105° pivot angle.

In order to improve your view of the grain tank unloading tube, the pivot angle has been increased from 101° to 105°. You can select the length in accordance with the width of the front attachment. The diameter depends on the desired unloading rate: 420 mm for 180 l/s or 330 mm for 80 to 130 l/s.

Grain tank unloading tube 7XL.

The 7XL grain tank unloading tube makes it possible to use the CTF (Controlled Traffic Farming) principle to protect the soil while working. The transport vehicle can follow 12 m away in the track which the combine harvester made during the previous pass.

Precise GRAIN QUALITY CAMERA.

The GRAIN QUALITY CAMERA provides real-time pictures of the crop. As the software identifies non-grain constituents and broken grains, you can use CEBIS to monitor the grain quality and assess it digitally at any time.

Grain elevator with 80 l/s.

In view of the high throughput, the feed rate of the grain elevator has been increased to 80 l/s. The integrated moisture meter takes samples straight from the elevator and returns them once the measurement has been performed.

Fast crop inspection.

The port for manual inspection of the crop is situated in the cab access area. Even when the content of the grain tank is low, there is sufficient crop available here to allow you to take the first samples as soon as you start threshing.



This is how you empty the grain tank in record time.



Its straw management is excellent.



Top quality straw chopping.

Use CEMOS AUTO CHOPPING to improve the quality of the chopped straw. Awarded the DLG Silver Medal in 2019, this system continuously determines the straw moisture content and quantity and automatically adjusts the static knife and friction concave plate positions in the straw chopper to the current condition of the straw. This can save up to 10% on diesel use.

Technology that makes your straw management efficient:

- SPECIAL CUT with up to 108 knives
- Hydraulic or mechanical adjustment of the static knife array to three positions
- Switchover to swathing from the cab

Three straw chopper drives.

In addition to two straw chopper drives with a manually adjustable chopper speed, there is also a version with hydraulic speed adjustment which can be controlled conveniently from the operator's seat. This option comes into its own when you have to work frequently in changing crop types. During swathing, a neutral setting saves fuel and reduces wear.

Precise power spreader.

The power spreader from CLAAS is synonymous with precise straw spreading – even with high volumes of straw, strong crosswinds or sloping terrain. Comprising two discharge rotors turning in opposite directions at a constant speed, it takes both the chopped material and the chaff straight from the cleaning section, accelerates it further and spreads it evenly across the entire working width.

Automatic discharge direction adjustment.

You can equip your LEXION with two sensors which automatically adjust the discharge direction of the chopped material to the terrain conditions. The sensors are fitted on the light brackets at the rear of the machine and ensure that the power spreader and deflector spread the chopped material evenly on slopes or in the event of crosswind. You set the sensitivity of this system in CEBIS.

Targeted chaff spreading.

During swathing, the chaff blower automatically turns outwards. Swaths of long straw and chaff/broken straw mixture are laid separately. For straw spreading, however, the chaff blower forces the sieve pan discharge straight into the power spreader and deflector spread the chopped material evenly on slopes or in the event of crosswind. You set the sensitivity of this system in CEBIS.



Static knife and pivoting bottom element in SPECIAL CUT chopper

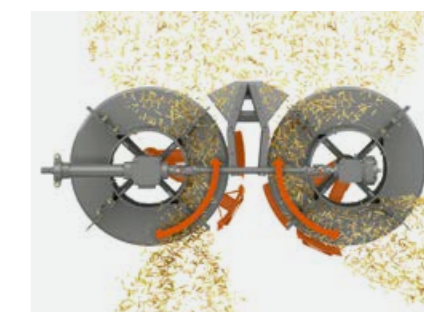

Power spreader for efficient straw spreading with minimal use of power

Every revolution needs power.
CLAAS POWER SYSTEMS.



CPS | CLAAS POWER SYSTEMS

Our drive system: optimal components interacting optimally.

A CLAAS machine is much more than the sum of its individual parts. Top performance is only possible when all the parts are ideally matched and work together optimally. The name CLAAS POWER SYSTEMS (CPS) stands for a combination of the best components which we have brought together to create an intelligent drive system.

Full engine output only when it is required. Drives that are suited to the way the machines are used. Fuel-saving technology which quickly pays off.

DYNAMIC POWER - the intelligent way to put power down.

More intelligence for the engine.

DYNAMIC POWER automatically adjusts the engine output of your LEXION to the operating conditions. This means that you are always running with the most efficient power curve when operating under partial load and can save – during swathing, for example – up to 10% of fuel. At full load when the grain tank is being unloaded and the straw chopper is engaged, for example, maximum engine output is automatically maintained.

Lower revs on the road.

On the road, the LEXION makes do with just 1,600 rpm. This technology makes it possible for you to save significantly more fuel while running at a reduced noise level and with a high level of driving comfort.



New features that help you save fuel:

- DYNAMIC POWER adjusts the engine output to the current power requirement
- Fuel savings of up to 10% are possible
- The engine speed is reduced to 1,600 rpm during road travel
- This significantly reduces the noise level and diesel consumption

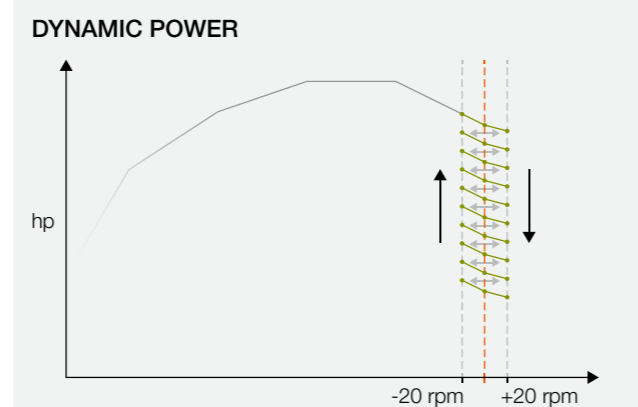

Intelligent power.

DYNAMIC POWER uses a variety of power curves on the basis of the engine load. The parameter which triggers the power adjustment is the reduction or increase in the engine speed resulting from a change in the power requirement.



Perkins 2206 D.

- Six-cylinder in-line layout with 12.5 l displacement
- Reduced rated engine speed of 1,800 rpm
- Emissions standard Stage III A (Tier 3)



Good access and easy maintenance.

- Safe access to engine compartment via ladder
- Air filter by access steps for easy removal
- Long maintenance intervals as only pre-cleaned air is drawn in

DYNAMIC COOLING - the smart solution.



Intelligence saves diesel.

Based on a variable fan drive which is unique in the combine harvester sector, DYNAMIC COOLING adjusts its speed automatically and, above all, in accordance with the degree of cooling required.

Whatever the outside temperature, DYNAMIC COOLING is able to cope easily. The system not only delivers reliable cooling, but also uses a curtain-effect air flow to reduce the extent to which dust is able to rise. DYNAMIC COOLING requires 20 kW less engine output, thereby helping you to save fuel.

What makes DYNAMIC COOLING so unique:

- Variable fan drive provides cooling when required
- Provides effective and reliable cooling
- Uses full fan speed only under full load
- Minimises extent to which dust is able to rise
- Reduces soiling of the radiator and engine compartment
- With grain tank unloading tube extended, automatically increases speed to actively blow dust away from engine compartment
- Extends the air filter maintenance intervals

Cooling and cleaning in one.

Drawn in vertically at the top, the fresh air passes through a rotating sieve with a diameter of 1.60 m. It is then vented through the engine compartment and over side cooling fins. This ideal air flow prevents almost all dust from rising and so effectively functions as a permanent cleaning system.

Large cooling package for sufficient reserves of cooling capacity.

- 1 Radiator
- 2 Oil cooler
- 3 Intercooler
- 4 Condenser
- 5 Fuel cooler



Smart drive concepts that pay off.



Hydrostatic ground drive up to 40 km/h.

All LEXION models are equipped with a 2-speed hydrostatic ground drive with convenient gear selection via the buttons on the armrest. The high efficiency of the hydrostatic motor saves power which is available to the rest of the machine. Both the wheeled machines and the TERRA TRAC models can travel at up to 40 km/h.

Automatic parking brake for your safety.

If you run for more than one second at less than 1 km/h, change gear, switch the engine off or get out of the seat, the LEXION automatically activates the parking brake. This increases both driving comfort when making frequent stops and your safety when you leave the cab. The brake is released again as soon as you operate the ground speed control lever.



40

40 km/h top speed for all wheeled machines and TERRA TRAC models



Differential lock for improved traction.

The electrohydraulically operated differential lock, which is activated simply by means of a pushbutton in the centre console, ensures that you can continue to operate safely and reliably in extreme conditions. The high traction and pulling power of the LEXION are maintained on slopes and in the wet. You can also engage the differential lock under load.

Automatic function for more comfort.

The differential lock automatic engagement and disengagement function makes working with the LEXION particularly comfortable and safe.

- Automatic engagement when ground speed is less than 10 km/h, steering angle less than 15° or slippage occurs
- Automatic disengagement when ground speed is over 10 km/h, steering angle over 15° or braking occurs

Tyres for high level of soil protection.

Tyres with a diameter of up to 2.15 m on the front axle and 1.71 m on the rear are gentle on the soil. Developed in an intensive joint effort with renowned manufacturers, the tyres are designed for the increased loads associated with the greater grain tank volumes and wider front attachments of the new LEXION. Featuring a significantly increased contact area, they are able to provide more traction, less slippage and reduced fuel consumption.

The optimal tyre pressure - automatically.

Using its tyre pressure control system on the rear axle, the LEXION adjusts the tyre pressure automatically to the prevailing conditions on the road or in the field. You only have to set the required values in CEBIS once.

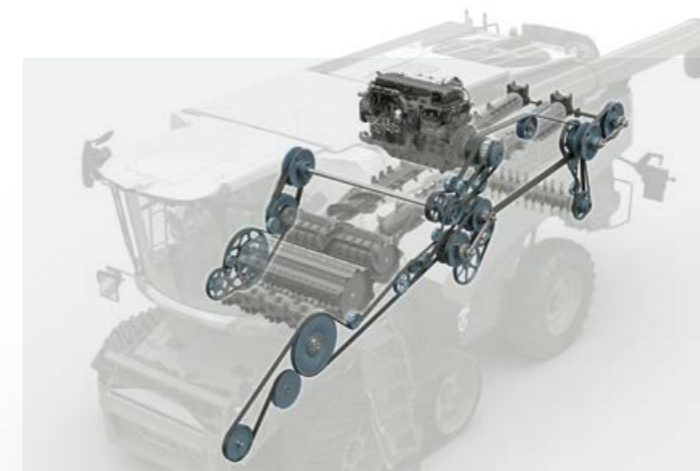

A drive concept that has what it takes:

- Hydraulically actuated dry clutch
- Hydraulically tensioned main belts
- Standardised belt tensioners
- As many as two belts and two chains less
- Improved power transmission
- Lower maintenance costs

The soil is your greatest asset.



TERRA TRAC for every requirement.



TERRA TRAC 635 mm



TERRA TRAC 735 mm



TERRA TRAC 890 mm



TERRA TRAC 890 mm
spoke design



TERRA TRAC 890 mm Rice

Third-generation crawler unit.

The soil is the most important basis for production available to you. As it is impossible to create more of it, you need to be able to obtain ever greater yields from the existing land. The key to this is more productive machines which, thanks to TERRA TRAC, are extremely gentle on the soil.

The third generation of TERRA TRAC crawler tracks impresses with the large diameter of the land wheels, hydropneumatic suspension, improved track tensioning and automatic level compensation from 2 km/h. The TERRA TRAC system increases traction drastically and leaves hardly any trail behind it when operating in the wet, on soft ground or on side slopes. This makes the work of the transport vehicles considerably easier.

TERRA TRAC on the road.

- 40 km/h top speed possible
- Fully suited to road travel at 20, 25, 30 and 40 km/h
- High driving safety and directional stability
- More driving comfort compared with a wheeled machine

TERRA TRAC in the field.

- Up to 66% less ground pressure than wheeled machines
- Better traction in maize, in the wet and on slopes
- Less slip and greater stability on side slopes
- Lower drive resistance and fuel consumption

TERRA TRAC in rice.

- Special rice track, 890 mm wide
- Greater spacing of tread lugs for self-cleaning
- High traction and load-bearing capacity
- Will not sink in when operating in wet field conditions

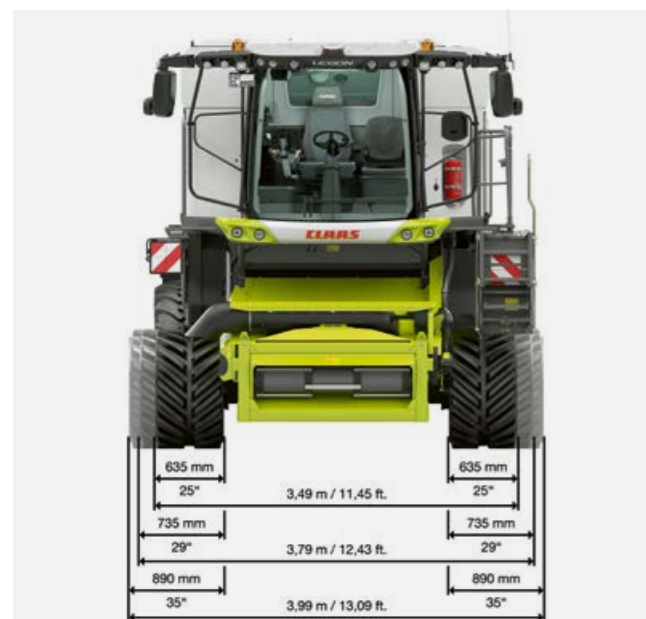

LEXION 8000 TERRA TRAC

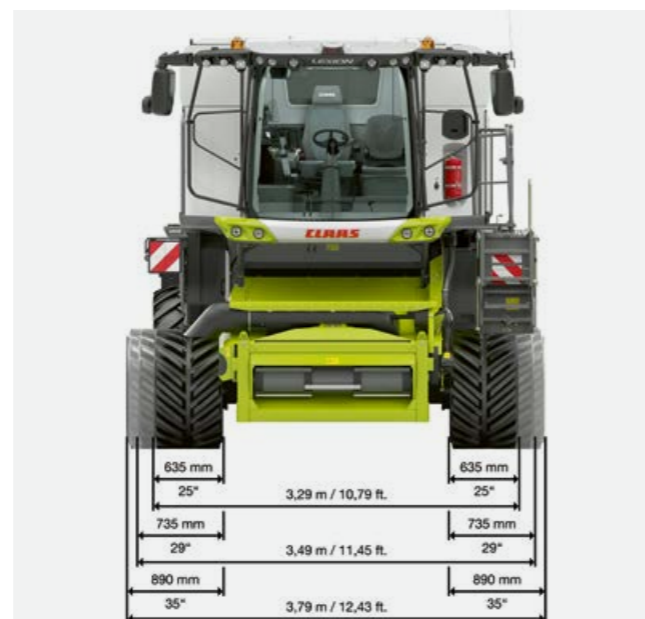

LEXION 7000 TERRA TRAC

Productivity calls for comfort.

More support for the operator.

With self-learning operator assistance systems, such as CEMOS AUTOMATIC and the comprehensively expanded functionality of CEMOS AUTO THRESHING, the new LEXION is able to work more efficiently than any previous combine harvester – regardless of whether you send it out into the field in the early morning or late at night. To help ensure that your operators are as productive, focused and relaxed as possible at all times, everything in the new cab is designed for comfort. The intelligent control concept supports them during every task.

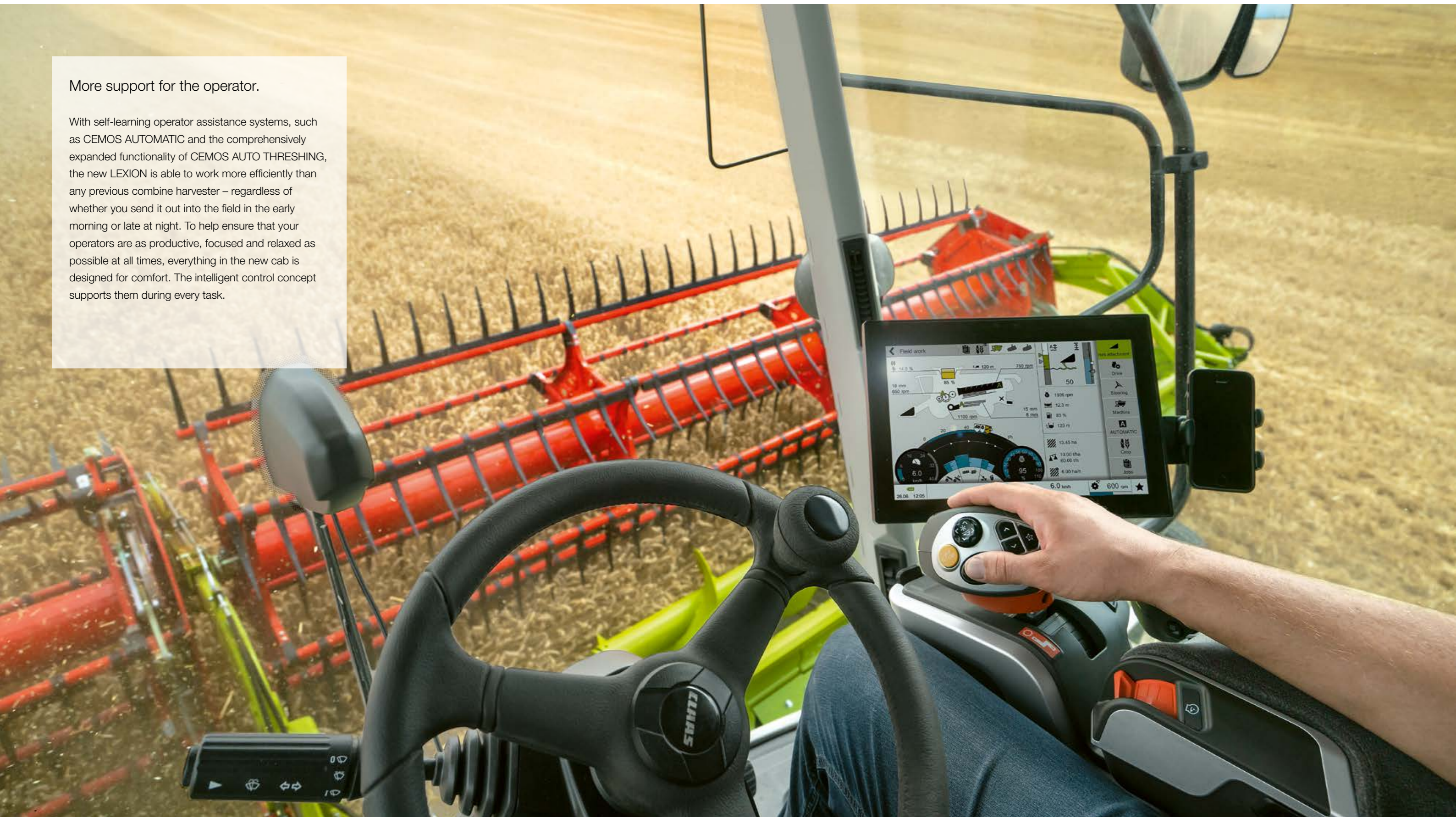

We give operators what they want.



Make the most of the new LEXION comfort.

More shoulder room in the cab, a new CEBIS terminal with touchscreen and an armrest, in which the switches for direct adjustment of the most important functions are integrated – these are just some of the many new features with which the LEXION makes the task of harvesting easier.

Cab equipment.

- 1 NEW: Adjustable, narrower steering column
- 2 NEW: CEBIS with touchscreen
- 3 NEW: More interfaces and connection options
- 4 CMOTION multi function lever
- 5 NEW: Armrest providing direct adjustment of the most important functions
- 6 Adjustable comfort operator's seat
- 7 Comfortable instructor's seat

- 8 NEW: Cool box with active cooling
- 9 Bright internal cab lighting
- 10 A/C MATIC automatic climate control
- 11 Front and side sunblinds
- 12 NEW: Washer and wiper system for the side windows
- 13 Printer for CEBIS
- 14 Large grain tank inspection window

Turn night into day.

LED light packages provide reliable illumination for the entire work area and key machine components.

- Stubble lights
- Main and dipped beam
- Marker lights
- Direction indicators
- Front area illumination
- Front attachment illumination
- Sidefinder
- Grain tank unloading tube
- Rear spotlights
- Side panels
- Returns, sieve pan, grain tank
- Steering axle
- Engine compartment
- Tool box
- Access lighting
- Tank filler lighting

Trust your intuition.

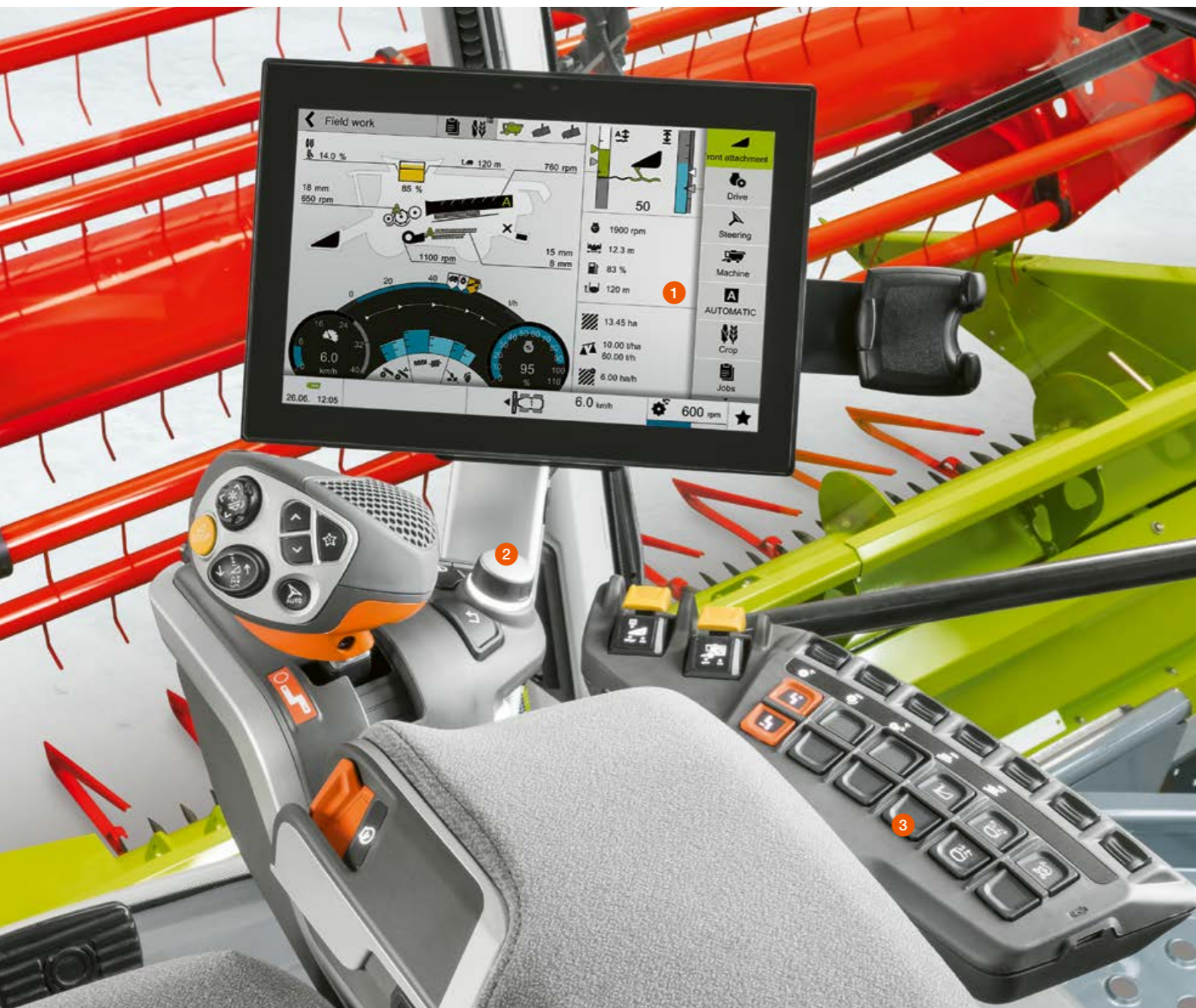

Reliable operation, three ways.

Depending on the operator's preference, the settings of the LEXION can be adjusted in three ways. Operation is intuitive and possible without previous knowledge. This means that even new operators are able to use the machine's performance capacity to the full in a short time.

- 1 Via the CEBIS touch function
- 2 Via the CEBIS rotary push switch
- 3 Via switches for direct adjustment



7 direct adjustment switches.

The operator can adjust the most important functions directly by means of switches identified by self-explanatory symbols. At the same time, a large dialogue box opens in CEBIS to show the changes made.

- 1 Threshing drum speed
- 2 Threshing concave distance
- 3 Fan speed
- 4 Upper sieve opening
- 5 Lower sieve opening
- 6 Rotor speed
- 7 Rotor flaps



13 functions at your fingertips.

The CMOTION multifunction lever has been specially developed for the ergonomics of the right hand. The three-finger control concept allows several functions to be controlled intuitively without repositioning one's hand.

- 1 Ground speed / direction of travel
- 2 Front attachment: cutting height / ground pressure
- 3 Front attachment: pre-set cutting height
- 4 Front attachment: manual raising and lowering
- 5 Reel setting for cutterbars
- 6 Front attachment: stop
- 7 Favourites selection up
- 8 Favourites selection down
- 9 Open favourites management
- 10 Activate steering system
- 11 Grain tank unloading on / off
- 12 Grain tank unloading tube pivot out / in
- 13 Menu-dependent rocker switch / modification of values in favourites management



The multifunction lever is the more compact alternative to CMOTION



Discover how easy it is to control the new LEXION.

You can be good and still get even better.

CEBIS offers immediate assistance.

Stored in CEBIS is a library of measures - based on the experience of countless LEXION operators - for resolving various problem scenarios. They consider and prioritise all the measures which could contribute to solving the problem. They therefore represent a comprehensive aid resource for making optimal use of the installed capacity of the machine.

CEBIS simplifies the menu.

Beginner, normal or expert: you define your user type and CEBIS adjusts the menu system to your level of experience. This ensures that new operators are not overwhelmed by complex menus.

CEMOS AUTOMATIC assists the operator.

The CEMOS AUTOMATIC operator assistance system is controlled comfortably via the CEBIS touchscreen. Using a simple slide controller, you tell the system which optimisation strategy you wish to use. A further reduction in the operator workload is made possible by the combination of CEMOS and the GRAIN QUALITY CAMERA which automatically detects and adjusts the grain quality, threshing quality and standard of cleaning.



Performance optimisation in CEBIS



Intelligent control by CEMOS AUTOMATIC



New features which make CEBIS even more convenient:

- CEBIS touch function and direct adjustment in the armrest are combined
- Operating the direct adjustment system causes a dialogue box to open in CEBIS

- Direct access to all functions is also possible via CEBIS
- All parameters can be modified easily by means of dial and slide controllers in CEBIS
- A numeric keypad helps the operator enter precise target values

CEBIS keeps you informed precisely.

- 1 Machine silhouette with quick access
- 2 Travel speed
- 3 Returns volume, grain content in returns, sieve and rotor losses, non-grain constituents and broken grains
- 4 Engine load
- 5 Vehicle information
- 6 Favourites management
- 7 Performance data
- 8 Freely configurable display area
- 9 AUTO CONTOUR front attachment guidance
- 10 Main menu
- 11 Job menu
- 12 Favourite crops, (freely configurable with three crop types)
- 13 Switch between machine silhouette and camera image

CEMOS operators are unbeatable.

CEMOS AUTOMATIC sets things up for you.

The CEMOS AUTOMATIC self-learning operator assistance system provides the operator with continuous, active support throughout the entire work process. On the basis of agricultural economics parameters, such as grain quality, threshing quality, standard of cleaning, straw quality and throughput, the system checks sensors and settings, optimising the LEXION to its technical performance limits while it is running.

The operator decides.

It is up to you to decide if you are happy with the degree of optimisation and wish to accept the fine adjustments suggested. CEMOS AUTOMATIC can be overridden manually at any time but can also be reactivated via the multifunction lever.

Harvesting at the limit.

CEMOS AUTOMATIC autonomously determines the best setting for every field.

- Your operators' workload is reduced significantly
- They achieve more throughput and an excellent standard of grain cleaning
- The fuel efficiency of your machine is improved
- You have no outages as a result of incorrect settings
- You reduce costs and effort effectively



Experience system intelligence in action.

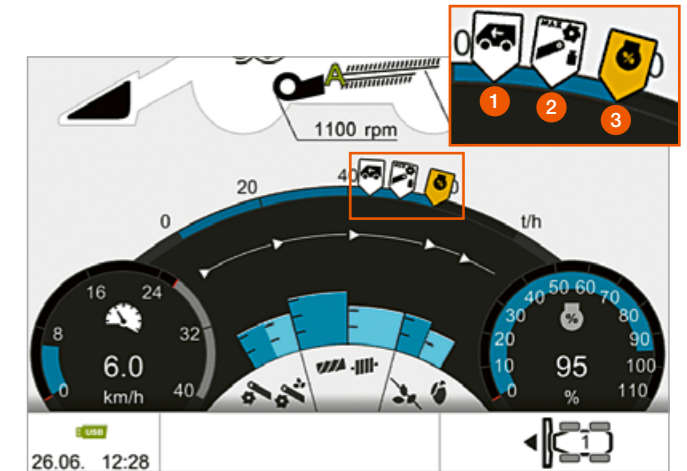
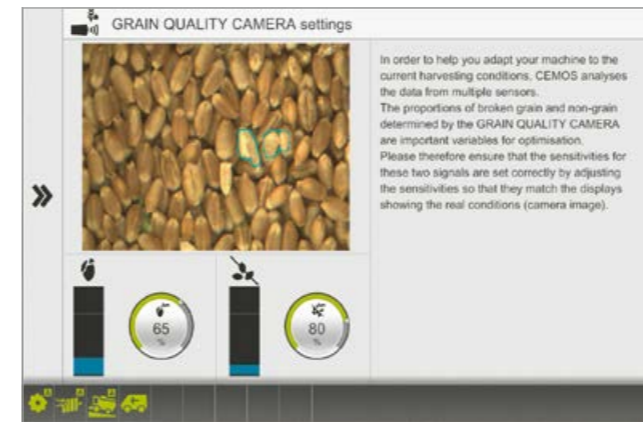

CEMOS AUTO THRESHING.

The system provides fully automatic adjustment of the threshing concave clearance and the threshing drum speed as well as the position of the pivoting concave bar and the threshing concave flap. In the background, it continuously tests various measures to optimise performance using the data from the

- GRAIN QUALITY CAMERA
- GRAINMETER
- QUANTIMETER
- CRUISE PILOT sensor
- Throughput monitoring, secondary separation, cleaning

CEMOS AUTO CLEANING.

The fan speed and the upper and lower sieve opening are the parameters by which CEMOS AUTO CLEANING regulates the cleaning.

CEMOS AUTO SEPARATION.

CEMOS AUTO SEPARATION continuously optimises the secondary separation by automatically adjusting the rotor speed and the rotor flap position in accordance with any change in the harvesting conditions.

CEMOS AUTO CHOPPING.

The positions of the static knife and the friction concave plate are automatically adjusted to the current condition of the straw in order to improve the quality of the chopped material.

CEMOS performance analysis.

The LEXION always keeps you informed about the scope for performance optimisation – and it is able to manage this with far greater precision than an operator could ever do manually. The most significant factors limiting throughput are displayed permanently:

- CRUISE PILOT, speed is limited (1)
- Maximum crop volume in feeder housing (2)
- Maximum engine load (3)
- Threshing unit load
- Separation losses
- Cleaning losses
- Returns volume limit

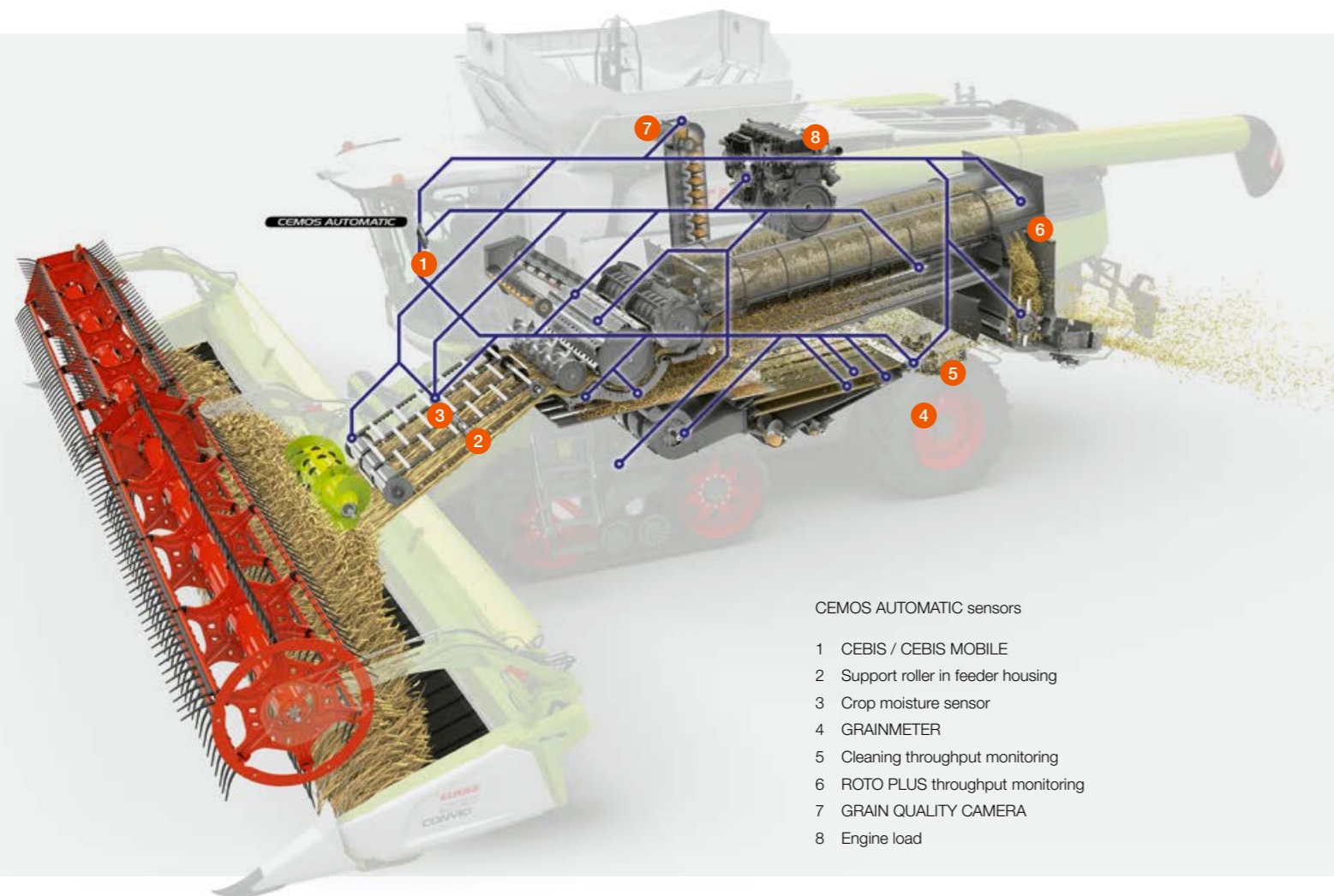

CEMOS AUTOMATIC sensors

- 1 CEBIS / CEBIS MOBILE
- 2 Support roller in feeder housing
- 3 Crop moisture sensor
- 4 GRAINMETER
- 5 Cleaning throughput monitoring
- 6 ROTO PLUS throughput monitoring
- 7 GRAIN QUALITY CAMERA
- 8 Engine load

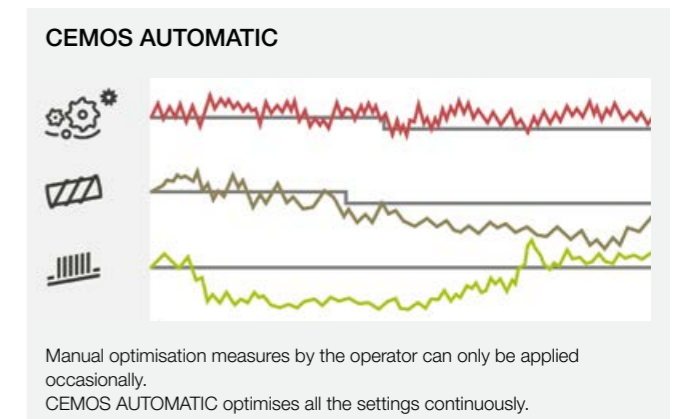

Manual optimisation measures by the operator can only be applied occasionally. CEMOS AUTOMATIC optimises all the settings continuously.

Assistance systems don't get tired.

AUTO CROP FLOW recognises peak loads.

CLAAS operator assistance systems were developed to make your operators safer, to make your harvesting run more smoothly and to reduce your costs. AUTO CROP FLOW continuously monitors the respective speeds of the APS SYNFLOW threshing unit, the secondary separation section and the engine.

If the preset slip limit is overshoot, the system automatically takes measures to prevent any more material from entering the machine. In this way, downtime because of blockages or damage is avoided and components are not overloaded.

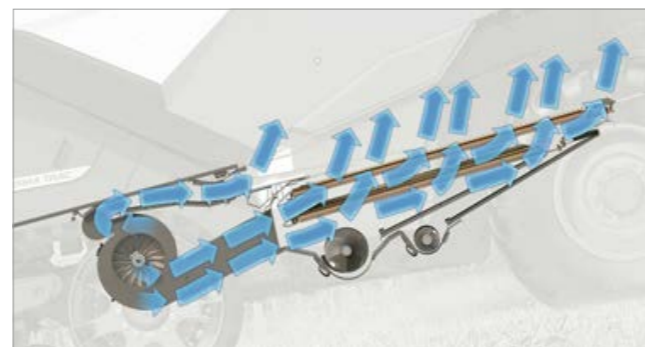
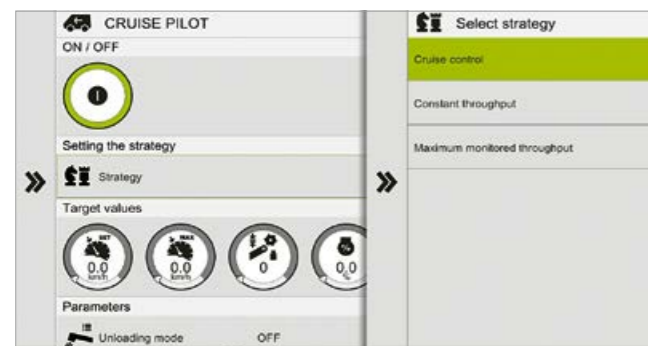
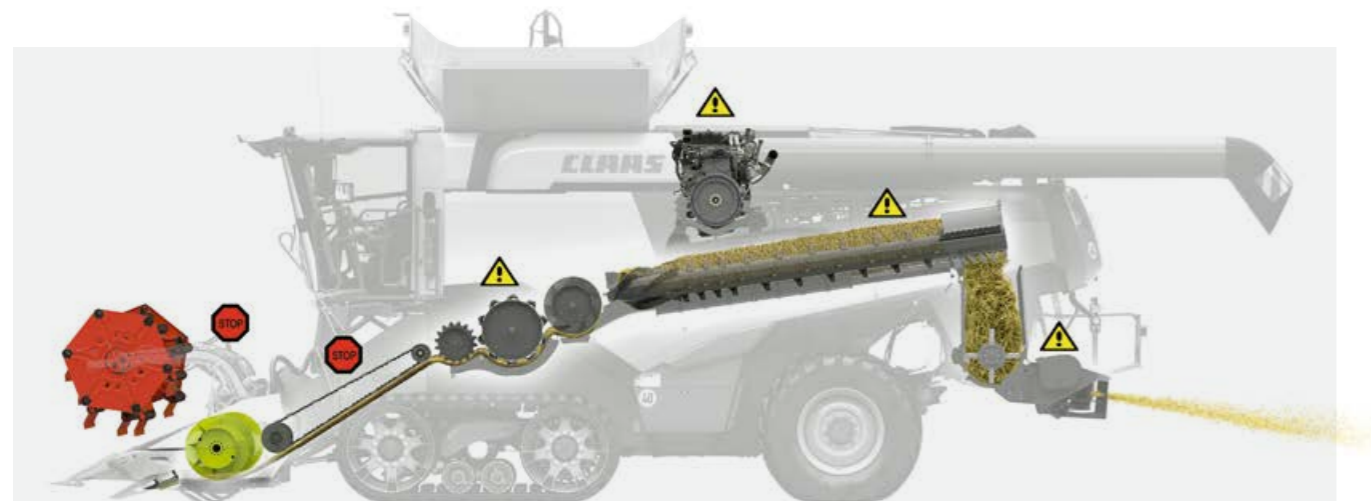

CRUISE PILOT controls the speed.

The optimal harvesting speed increases your productivity. CRUISE PILOT controls it automatically on the basis of the engine load. It is possible to choose from three strategies:

- Cruise control: harvest at a constant speed
- Performance: harvest with maximum throughput
- Throughput: harvest with maximum throughput with consideration of losses

AUTO SLOPE manages cleaning on slopes.

Hilly fields are a challenge for the grain cleaning system. Uphill, the fan speed has to be reduced, downhill it has to be increased. AUTO SLOPE controls the fan speed and the sieve opening on the basis of the longitudinal tilt.

- More throughput and lower grain losses on slopes
- The cleaning performance always remains stable
- The crop flow in the cleaning system is maintained
- The operator's workload in undulating terrain is reduced



The free CEMOS Advisor smartphone app is a valuable adjustment aid for the operator. It comes with an integrated lost grain calculation function.

CEMOS DIALOG motivates the operator.

The CEMOS DIALOG assistance system guides the operator to the optimal machine setup. Settings confirmed by the operator are implemented directly by CEMOS DIALOG.

- Operators are motivated to check settings more frequently and to optimise them
- They are more confident about adjusting settings
- Even experienced operators benefit from the learning effect

The future is connected.

Connected machines are more productive.

Artificial intelligence is a key factor for efficiency. To enable you to get more out of your CLAAS machines than ever before, CLAAS offers you a variety of modules to connect both machines and farm.

Yield mapping lets you see things in a new way.

Sensors in the LEXION measure the yield and grain moisture. CEBIS uses GPS satellites to complement these data with geographical coordinates. The AGROCOM MAP software, which is included, combines the two datasets to generate informative yield maps which have a major influence on your future production strategy.

FLEET VIEW coordinates the fleet.

With FLEET VIEW, you can coordinate the grain transport team in your harvesting fleet in such a way that the combine harvesters can keep on working without idle time. The app informs you in real time about the position of the machines and their grain tank fill levels. You always know which machine needs to be unloaded next. In this way you can avoid idle time and unnecessary vehicle travel, save fuel and make full use of the harvesting machines' capacity.

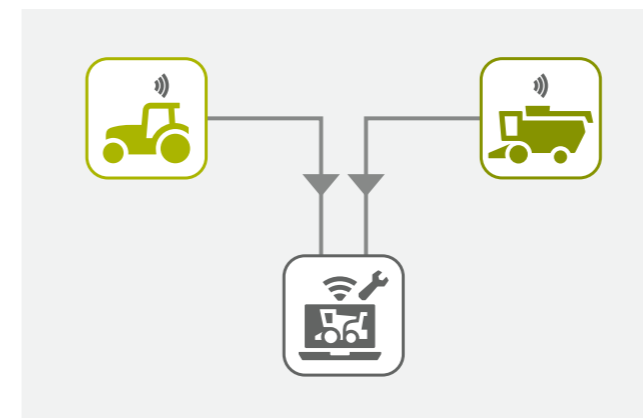
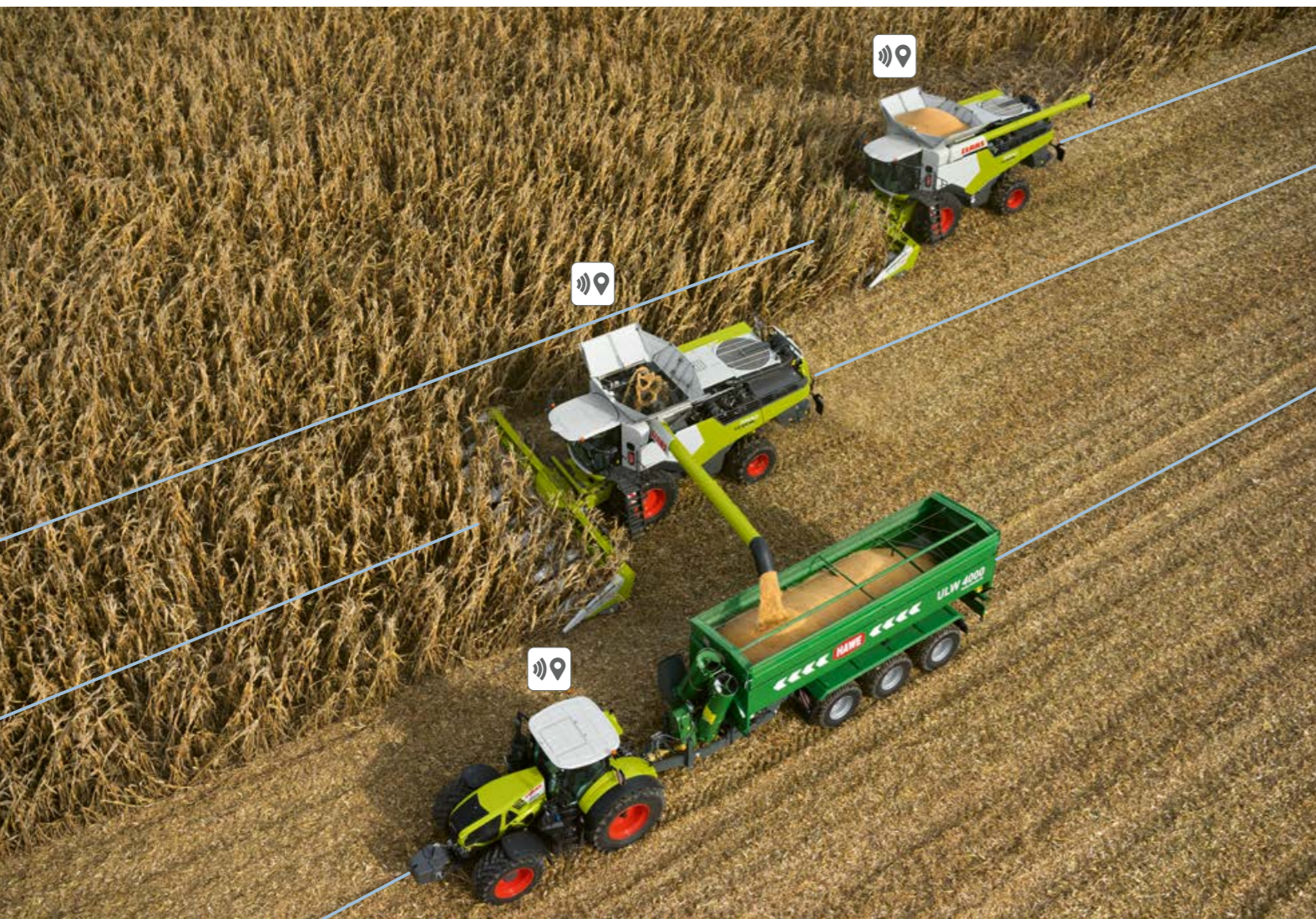
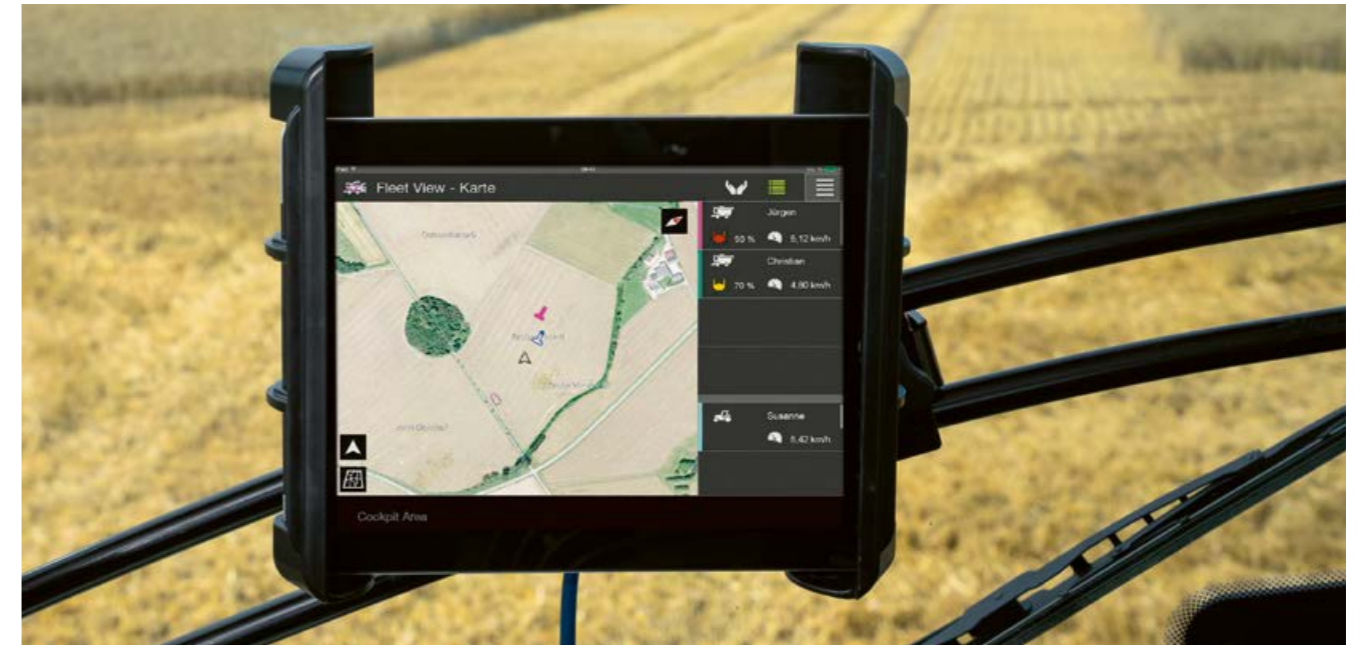

Remote Service costs you nothing.

Remote Service from CLAAS is an important machine connection element. It simplifies maintenance and service support significantly. The machine informs the service partner of an upcoming requirement for maintenance or sends immediate notification if a fault arises. The service partner has access to the relevant data and can prepare optimally for the intervention in both scenarios. CLAAS covers the cost of Remote Service for you during the first five years. All you have to do is give your consent.

TELEMATICS records your success.

Work data, tracks and yield data for your combine harvester can be retrieved and recorded continuously by means of TELEMATICS. All data are transmitted via the mobile phone network from the machine to the server, where they are processed and stored. You can access and evaluate your data online in real time or retrospectively via the TELEMATICS website using your farm PC, laptop or smartphone. It is also possible to export your data to any current farm management software programme.

Don't waste a single centimetre.

Keep the number of passes to a minimum.

Steering systems are an essential tool in your everyday work. Thanks to them, precision to the nearest centimetre is no longer an art. The LEXION is equipped with three automatic steering systems, which you can choose between on the basis of the task in question: the electro-optical LASER PILOT, the digital AUTO PILOT and the satellite-based GPS PILOT.

LASER PILOT for the left-hand edge of the crop.

The electro-optical sensor of the LASER PILOT uses pulses of light to scan the edge between the harvested and unharvested areas and in this way guides the LEXION automatically along the left-hand edge of the crop. The LASER PILOT can be folded and is available for the left-hand side of the cutterbar.

NEW: LASER PILOT with FIELD SCANNER.

As an option, you can replace the sensors at the outer edges of the cutterbar with a FIELD SCANNER which is fitted centrally on the cab roof.

- You no longer need to fold the sensors out and in before and after use
- You don't have to bother with calibration
- Buttons on the control lever are used to activate the three steering modes: along the right or left edge of the crop or along the tramline

AUTO PILOT.

Two digital sensors incorporated in one of the snapping units of the maize picker guide the LEXION automatically through the rows of maize, thereby ensuring it is in the optimal position in the crop.

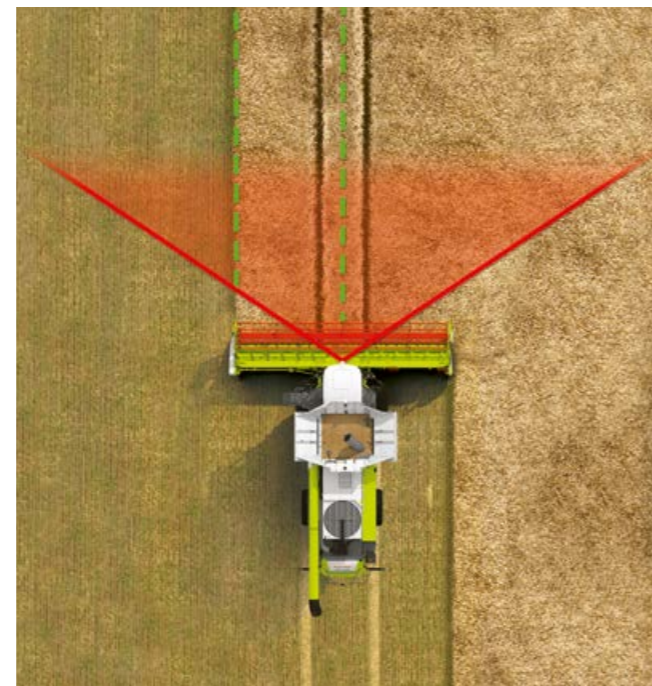

GPS PILOT with unbeatable steering precision.

The satellite-based, automatic steering system from CLAAS is permanently integrated in the machine and supports you in all tasks which depend on maximum pass-to-pass accuracy.

- Actively controls the steering hydraulics
- Guides you across the field precisely at all speeds
- Even in foggy or dark conditions
- Correction signals available for all accuracy requirements



S10 terminal for ISOBUS and GPS.

- High-resolution 10.4" touchscreen
- Operates and controls GPS steering system and ISOBUS attached implements
- Up to four camera connections
- Reference line management, SECTION VIEW and AUTO TURN as standard

S7 terminal for GPS.

- High-resolution 7" touchscreen
- Controls parallel guidance or GPS steering system
- USB interface for data exchange and management
- Reference line management, SECTION VIEW and AUTO TURN as standard



Even large machines
can be maintained easily.



Reduced maintenance requirement.

Like all its predecessors, the new LEXION is also appreciated for being a model of restraint where maintenance requirements are concerned. The maintenance intervals are long: 1000 hours for the oil in the working hydraulics. And when it is time for maintenance work to be carried out, easy access to all the key maintenance points makes it a fast and simple process.

Reliable lubrication.

The central lubrication system supplies grease to all the lubrication service points, including the variators, as required. Lubrication points and intervals only need to be programmed once.

New features that simplify maintenance for you:

- The centrally routed drain hoses for engine oil and hydraulic oil are easily accessible
- All the variators are connected to the central lubrication system
- The air compressor with a reservoir enables cleaning tasks to be performed quickly, even in the field
- The grain tank can be accessed easily via the divided engine compartment cover which is designed to be walked on



Optimal accessibility.

The newly designed, robust engine compartment cover makes it significantly easier for you to access the grain tank and to perform any maintenance tasks required there. It is slip-resistant and designed to be walked on. Handrails and a folding step provide additional safety.

The wide access steps have collision protection and can be swivelled round to the front. They are also available in a folding version for use with the 8-row CORIO maize picker.



Well thought-out convenience package.

The convenient maintenance package features a number of practical solutions to make daily maintenance tasks more user-friendly:

- Secure bracket for the grease gun
- Water tank with 15 litre capacity
- Removable for filling
- Separate drain cock for hand washing on side of tool compartment

Automatic air hose reel.

The convenient maintenance package of the new LEXION also includes an air hose reel with a 15 m compressed air hose which can be unwound and wound up easily and tidily. The reel is locked as soon as you have unwound the hose. Pulling on the hose briefly causes it to be wound up again automatically. This feature makes fast interim cleaning in the course of the day even more convenient.



See how easy it is
to access the LEXION.

Whatever it takes. CLAAS Service & Parts.



Safeguard your machine's reliability.

Increase your operating reliability, minimise the repair and breakdown risk. MAXI CARE offers you predictable costs. Create your own individual service package to meet your particular requirements.



CLAAS Service & Parts is always there for you, 24/7.
service.claas.com



Specially matched to your machine.

Precision-manufactured parts, high-quality consumables and useful accessories. Choose our comprehensive product range to be certain of receiving exactly the right solution to ensure 100% operating reliability for your machine.

Get connected.

Remote Service allows your sales and service partner to access your machine and your specific data directly. This allows you and your CLAAS partner to respond quickly to maintenance and servicing situations. And with CLAAS TELEMATICS, you can access all of your important machine data via the internet, anytime, anywhere.



Global supply.

The CLAAS Parts Logistics Center in Hamm, Germany, stocks almost 200,000 different parts and has a warehouse area of over 140,000 m². This central spare parts warehouse delivers all ORIGINAL parts quickly and reliably all over the world. This means that your local CLAAS partner can supply the right solution for your harvest or your business within a very short time.



Your local CLAAS distributor.

Wherever you are, you can count on us to always provide you with the service and the contact persons you need. Your CLAAS partners are on hand in your local area, ready to support you and your machine around the clock. With know-how, experience, commitment and the best technical equipment. Whatever it takes.



- | | | |
|---------------------------------------|--|--------------------------------------|
| 1 FIELD SCANNER sensor | 9 Grain elevator with QUANTIMETER | 16 CEMOS AUTO CHOPPING |
| 2 Comfort cab | 10 Grain tank with up to 18,000 l | 17 Chaff fan |
| 3 CEMOS AUTOMATIC | 11 Grain tank unloading tube pivots through 105° | 18 Power spreader |
| 4 Feeder housing with dust extraction | 12 Grain tank unloading at up to 180 l/s | 19 TERRA TRAC with 40 km/h top speed |
| 5 APS SYNFLOW HYBRID threshing unit | 13 Cover flap for grain tank unloading tube | 20 Separate returns pan |
| 6 600 mm feeder drum | 14 DYNAMIC COOLING | 21 3D cleaning system |
| 7 JET STREAM cleaning | 15 Perkins engine | |
| 8 ROTO PLUS secondary separation | | |

Arguments that appeal to head and heart.



Efficiency.

- APS SYNFLOW HYBRID revolutionises throughput
- Large threshing and feeder drums provide a straight, even and fast crop flow
- DYNAMIC COOLING provides cooling as required
- DYNAMIC POWER saves up to 10% of fuel
- JET STREAM cleans your grain impeccably
- 18,000 l unloaded in 100 s
- 40 km/h gets you there quickly



Precision.

- CEMOS AUTOMATIC continuously optimises threshing unit, cleaning system and crop flow
- CEMOS AUTO THRESHING in CEBIS adjusts the threshing drum speed, threshing concave distance, threshing concave bar and flap
- AUTO SLOPE reduces your workload on slopes
- LASER PILOT and GPS steering keep the number of passes to a minimum
- Remote Service connects your machines and speeds up service support
- CEMOS AUTO CHOPPING optimises the chopped material quality and reduces fuel consumption



Comfort.

- The CEBIS touchscreen is as easy to use as your smartphone
- You can operate the CMOTION multifunction lever intuitively
- The direct adjustment function in the armrest allows you to access the most important functions
- You can react quickly to crop type changes
- The new 105° pivot angle improves the view of the grain tank unloading tube



Reliability.

- The revised drive concept impresses with its high efficiency
- The main drive engages gently via the dry clutch
- The use of belt conveyors instead of chains makes for smoother running and a longer service life
- The central lubrication system supplies all lubrication points, including the variators
- Safety is enhanced by the automatic parking brake

LEXION		8800 / 8800 TERRA TRAC	8700 / 8700 TERRA TRAC	7700 / 7700 TERRA TRAC	7600 / 7600 TERRA TRAC
Threshing unit and primary separation					
APS SYNFLOW HYBRID		●	●	●	●
Threshing drum width	mm	1700	1700	1420	1420
Threshing drum diameter	mm	755	755	755	755
Threshing drum speed	rpm	330-930	330-930	330-930	330-930
With reduction gear	rpm	170-460 / 330-930	170-460 / 330-930	170-460 / 330-930	170-460 / 330-930
Threshing concave wrap angle	degrees	132	132	132	132
Main concave area	m ²	1.55	1.55	1.30	1.30
Rice threshing unit		○	○	○	○
Secondary separation					
ROTO PLUS high performance rotors	No.	2	2	2	2
Feed drum diameter	mm	600	600	600	600
Rotor length	mm	4200	4200	4200	4200
Rotor diameter	mm	445	445	445	445
Rotor concaves	No.	6	6	5	5
Rotor speed	rpm	450-1250	450-1250	370-1050	370-1050
Crop cleaning					
JET STREAM		●	●	●	●
Turbine fan		8-way	8-way	6-way	6-way
Fan adjustment, hydraulic		●	●	●	●
Dual ventilated step		●	●	●	●
4D cleaning system		○	○	○	○
Total sieve area	m ²	6.20	6.20	5.10	5.10
Returns display in CEBIS		○	○	○	○
GRAINMETER		○	○	○	○
Grain tank					
Capacity (as per ANSI/ASAE S312.2)	l	13500/15000/18000	13500/15000/18000	12500/13500	11000/12500/13500
Unloading auger swivel angle	degrees	105	105	105	105
Unloading rate	l/s	130/180	130/180	130/180	130/180
QUANTIMETER yield meter		○	○	○	○

Greater height and reach for easy unloading.

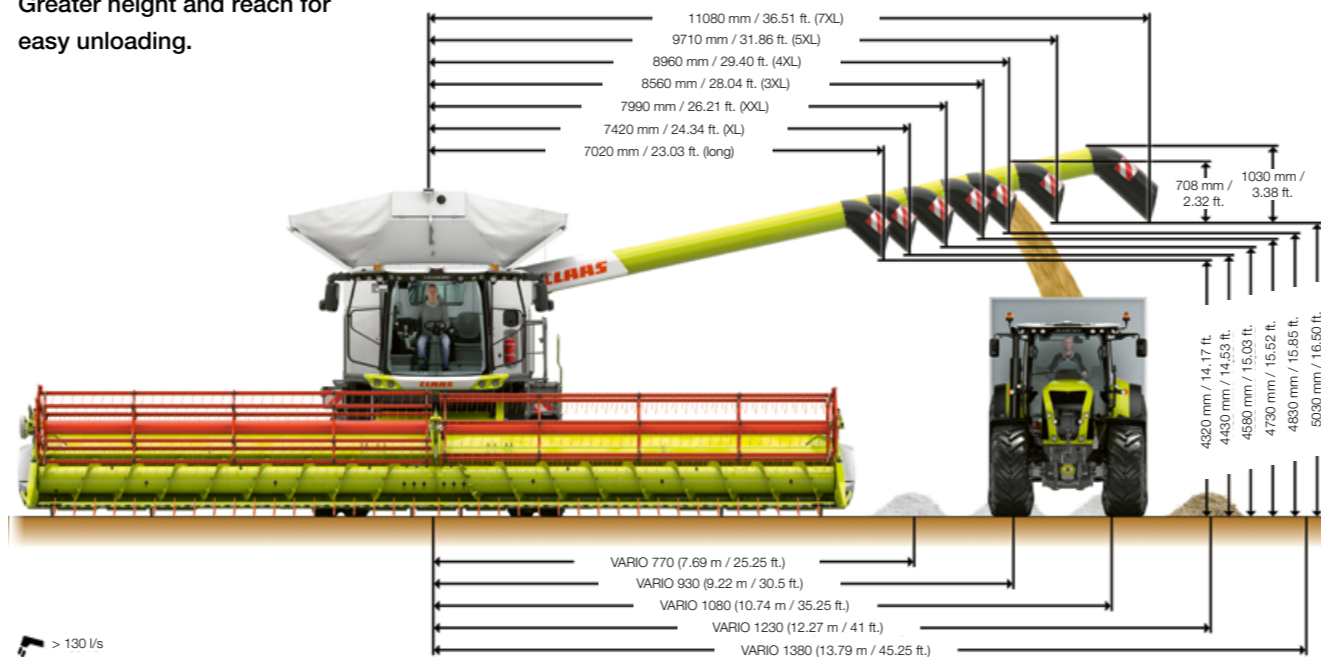

> 130 l/s

● Standard ○ Option □ Available – Not available

LEXION		8800 / 8800 TERRA TRAC	8700 / 8700 TERRA TRAC	7700 / 7700 TERRA TRAC	7600 / 7600 TERRA TRAC
Chopper					
SPECIAL CUT straw chopper, knives	No.	108	108	72	72
STANDARD CUT straw chopper, knives	No.	64	64	52	52
Power spreader		○	○	○	○
Hydraulic changeover from cab (road travel, swathing, chopping)		●	●	●	●
Hydraulic adjustment of static knife and friction concave plate		○	○	○	○
Chaff spreader		○	○	○	○
Chaff fan with power spreader		○	○	○	○
Automatic discharge direction adjustment		○	○	○	○
Running gear					
TERRA TRAC crawler tracks with hydropneumatic suspension		○	○	○	○
POWER TRAC all-wheel drive		○	○	○	○
2-speed manual gearbox		●	●	●	●
40 km/h		○	○	○	○
Differential lock for wheeled machine		○	○	○	–
Car-like driving characteristics		●	●	●	●

Engine Stage V		Mercedes-Benz OM 473 LA (Stage 5)		Perkins 2206 D	
Manufacturer / Type		Mercedes-Benz OM 473 LA (Stage 5)		Perkins 2206 D	
Cylinders / displacement	No./l	6/15.6	6/12.5	6/12.5	6/12.5
Maximum output (ECE R 120)	kW/hp	480/653	420/571	385/524	339/461
Fuel consumption measurement		○	○	○	○
Fuel tank capacity	l	1150	1150	1150	1150
DYNAMIC COOLING		●	●	●	●
DYNAMIC POWER		●	●	●	●
Data management					
TELEMATICS		●	●	●	●
Job management		○	○	○	○
Yield mapping		○	○	○	○
Remote Service		○	○	○	○

Operator assistance systems					
CRUISE PILOT		○	○	○	○
CEMOS AUTO THRESHING		○	○	○	○
CEMOS AUTO CLEANING		○	○	○	○
CEMOS AUTO SEPARATION		○	○	○	○
CEMOS AUTO CHOPPING		○	○	○	○
AUTO SLOPE		○	○	○	○
AUTO CROP FLOW		○	○	○	○
CEMOS DIALOG		○	○	○	○
GRAIN QUALITY CAMERA		○	○	○	○

Guidance systems					
GPS PILOT, LASER PILOT, AUTO PILOT		○	○	○	○
Weights (can vary depending on equipment) without front attachment, straw chopper and chaff spreader, full fuel tank, full urea tank	kg	19700/22400 (TERRA TRAC)	19700/22400 (TERRA TRAC)	18700/21400 (TERRA TRAC)	18700/21400 (TERRA TRAC)

As CLAAS continually develops its products to meet customers' requirements, all products are subject to change without notice. All descriptions and specifications in this brochure should be considered approximate and may include optional equipment that is not part of the standard specifications. This brochure is designed for worldwide use. Please consult your nearest CLAAS dealer and their price list for local specification details. Some protective panels may have been removed for photographic purposes in order to present the function clearly. To avoid hazards, never remove these protective panels yourself. Please refer to the relevant instructions in the operator's manual in this regard. All technical specifications relating to engines are based on the European emission regulation standards: Stage. Any reference to the Tier standards in this document is intended solely for information purposes and ease of understanding. It does not imply approval for regions in which emissions are regulated by Tier.

● Standard ○ Option □ Available – Not available

LEXION			8800 / 8800 TERRA TRAC	8700 / 8700 TERRA TRAC	7700 / 7700 TERRA TRAC	7600 / 7600 TERRA TRAC
--------	--	--	---------------------------	---------------------------	---------------------------	---------------------------

Tyres on drive axle

Tyre size		ø cat.	External width			
1250/50 R 32	m	2.05	5.15	5.15	4.87	—
VF 900/60 R 42 CFO	m	2.15	3.90	—	3.62	—
900/60 R 42 CHO	m	2.15	3.90	—	3.62	—
800/70 R 42 CHO	m	2.15	3.76	—	3.48	—
680/80 R 42 CHO	m	2.15	3.49	—	3.22	—
VF 900/60 R 38 CHO	m	2.05	3.90	3.90	3.62	3.62
900/60 R 38 CHO	m	2.05	3.90	3.90	3.62	3.62
IF 800/70 R 38 CFO	m	2.05	3.76	3.76	3.48	3.48
800/70 R 38 CHO	m	2.05	3.76	3.76	3.48	3.48
IF 680/80 R 38 CFO	m	2.05	3.49	3.49	3.22	3.22
680/80 R 38 CHO	m	2.05	3.49	3.49	3.22	3.22
900/60 R 32	m	1.95	3.90	3.90	3.62	3.62
IF 800/70 R 32 CFO	m	1.95	3.76	3.76	3.48	3.48
800/70 R 32	m	1.95	3.76	3.76	3.48	3.48
710/75 R 34	m	1.95	3.65	3.65	3.37	3.37
IF 680/85 R 32 CFO	m	1.95	3.63	3.49	3.28	3.35
TERRA TRAC 635 mm	m	—	3.49	3.49	3.29	3.29
TERRA TRAC 735 mm	m	—	3.79	3.79	3.49	3.49
TERRA TRAC 890 mm	m	—	3.99	3.99	3.79	3.79

LEXION			8800 / 8800 TERRA TRAC	8700 / 8700 TERRA TRAC	7700 / 7700 TERRA TRAC	7600 / 7600 TERRA TRAC
--------	--	--	---------------------------	---------------------------	---------------------------	---------------------------

Tyres on steering axle

Tyre size		ø cat.	External width			
710/60 R 30	m	1.65	3.89	3.89	3.69	3.69
VF 620/70 R 30	m	1.65	3.69	3.69	3.49	3.49
620/70 R 30	m	1.65	3.69	3.69	3.49	3.49
VF 520/85 R 30	m	1.65	3.49	3.49	3.29	3.29
500/85 R 30	m	1.65	3.47	3.47	3.27	3.27
VF620/70 R 26	m	1.50	—	—	3.49	3.49
750/65 R 26	m	1.60	—	—	3.74	3.74
600/65 R 28	m	1.50	—	—	3.69	3.49
500/85 R 24	m	1.50	—	—	3.48	3.28

Front attachments

VARIO cutterbars		VARIO 1380 ¹ , VARIO 1230 ¹ , VARIO 1080, VARIO 930, VARIO 770, VARIO 680, VARIO 620, VARIO 560
CERIO cutterbars		CERIO 930, CERIO 770, CERIO 680, CERIO 620, CERIO 560
Rapeseed equipment		For all standard and VARIO cutterbars, not available for CERIO cutterbars
Folding cutterbars		C 540, C 450
SUNSPPEED	rows	16, 12, 8
MAXFLEX		MAXFLEX 930, MAXFLEX 770, MAXFLEX 620, MAXFLEX 560
CONVIO FLEX		CONVIO FLEX 1380 ¹ , CONVIO FLEX 1230 ¹ , CONVIO FLEX 1080, CONVIO FLEX 930, CONVIO FLEX 770
CONVIO		CONVIO 1380 ¹ , CONVIO 1230 ¹ , CONVIO 1080, CONVIO 930, CONVIO 770
CORIO CONSPEED		1270 C, 1275 C, 880 FC, 890 C, 875 FC, 875 C, 870 FC, 870 C, 690 C, 680 FC, 675 FC, 675 C, 670 FC, 670 C
CORIO		880 FC, 875 FC, 875 C, 870 FC, 870 C, 680 FC, 675 FC, 675 C, 670 FC, 670 C
VARIO rice cutterbars		Available as HD version with rice harvesting accessory pack
CERIO rice cutterbars		Available as HD version with rice harvesting accessory pack
SWATH UP		SWATH UP 450
Variable speed drive front attachment (electrohydraulic)	rpm	284-420
Front attachment step drive	rpm	332, 420
Instant cutterbar brake		o

¹ Only for LEXION with TERRA TRAC



Ensuring a better harvest.

Landpower Australia Pty Ltd
 31-33 Marshall Court
 Altona
 Victoria 3018
 Australia
 Ph: 1800 425 227
 Fax: 03 9369 1944
 Email: info@landpower.com.au
 www.landpower.com.au

Landpower New Zealand Ltd
 45 Ron Guthrey Road, Harewood
 PO Box 16130, Hornby
 Christchurch 8441
 New Zealand
 Ph: 0800 425 227
 Fax: 03 357 6001
 Email: info@landpower.co.nz
 www.landpower.co.nz