



# TGS 8x8

# Chassis

▶ M Cab

ENGINEERED TO SAVE YOU MONEY ▶



# SPECIFICATION DATA

M CAB

GVM 42,000kg GCM: 90,000Kg

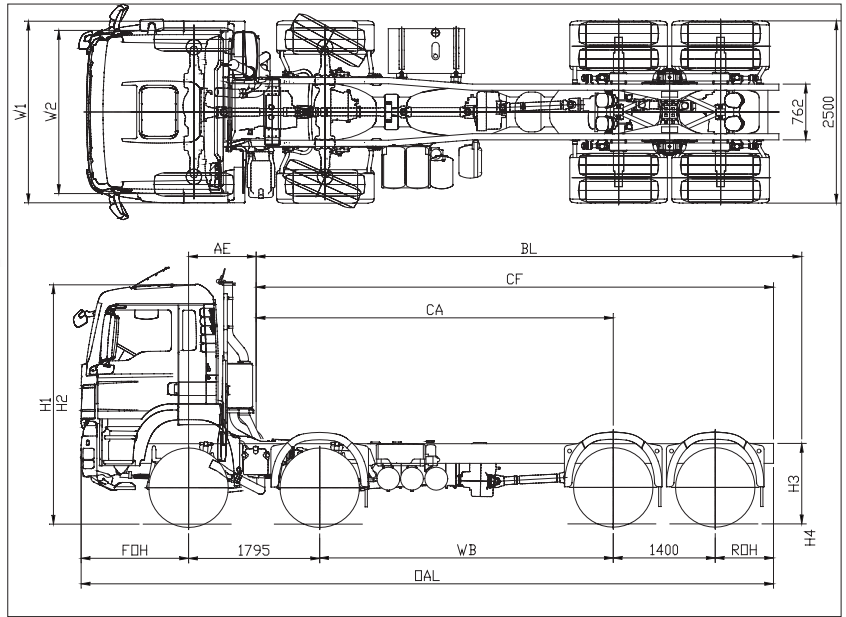
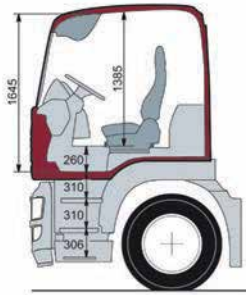

MANTGS8XSPEC16

	M CAB WEIGHTS			TURNING CIRCLE	
	Front (kg)	Rear (kg)	Total (kg)	Kerb to Kerb (m)	Wall to Wall (m)
4030mm	7765	4250	12015	25	27.4

	LX CAB CHASSIS DIMENSIONS (MM)							EMPTY	LOADED	EMPTY	LOADED	W1	W2
	FOH	ROH	OAL	CA	CF	AE	BL	H1	H2	H3	H4		
4030mm	1492	800	9517	4850	7050	975	9250	3370	3294	1180	1100	2490	2240

	ENGINE SPECIFICATIONS			TRANSMISSION SPECIFICATIONS		
	Model	Power Rating	Torque	Model	Transmission Ratios	Standard Differential Ratio
480HP	MAN D26 12.5 Ltrs	353kW @ 1900rpm	2300Nm @ 1050 – 1400 rpm	ZF 12 AS 2330 OD	12.33 – 0.78	4.00

1. All above weights and dimensions are subject to confirmation and may vary depending on final specification. Manufacturing weight tolerance +/- 3%.
2. State and Federal regulations over ride information supplied on this brochure.
3. Vehicle images in this specification sheet are for illustration purposes only.
4. Maximum body length is calculated using a rear overhang of 60% of the wheelbase to a maximum of 3.7m.
5. Tare weight includes 100 litres of fuel, spare wheel and steel wheels.
6. Specifications are subject to change without notice. Copyright © 2014, MAN Automotive Imports Pty Ltd.

**MAN Automotive Imports Pty Ltd**  
 72 Formation Street, Wacol, QLD 4076 • PO Box 301, Goodna QLD 4300  
 T: (07) 3271 7777 • [www.man.com.au](http://www.man.com.au)

