

The Econic.



Responsibility is why.

Mercedes-Benz
Trucks you can trust



The Econic concept: putting people first.

Just as our cities are growing, so too are our requirements for mobility, logistics, the environment and quality of life. Our solution is a commercial vehicle that measures up to these challenges. One that is powerful and efficient, yet at the same time offers maximum safety for all road users. One that delivers sustainable solutions to the increasing emissions levels in urban areas and ensures optimum working conditions for both driver and crew.

A responsibility that the Econic is translating into action. As evidenced by the powerful drivetrain, a body-friendly design and the all-important safety credentials provided by the DirectVision Cab with panoramic glazing and sophisticated assistance systems. The ergonomic entry and exit, intuitive instrument layout and the optionally available natural-gas engine – for unrestricted operation in environmental zones – provide the optimum urban solution. Looking to the future together.

The Econic. Responsibility is why.

Contents.

DirectVision Cab	4
Safety at work with the low-entry concept	5
Safety assistance systems	6
Ergonomic working area	8
Drivetrain technologies	10
Waste management	12
Urban distribution	14
Fire service	16
Construction operations	18
Airport	20
Body solutions	22
Quality and service	23





Anticipatory driving at eye level.

Low seating position and DirectVision Cab.

The Eonic is perfectly suited for use in urban traffic. Its exceptional low-entry concept offers a number of convincing benefits, the most notable being the cab with panoramic glazing which provides an unobstructed view. The low seating position means that the driver is at eye level with other road users. Having a better view of things enables drivers to react more quickly. Furthermore, they are able to communicate directly with other road users through eye contact. An advantage which, in a hectic traffic environment, can be crucial.



- DirectVision Cab for maximum visibility
- Low driver's seat position for direct eye contact
- Fully glazed folding door on the passenger side providing a clear view of the pavement
- Mirror system for expansion of field of vision to encompass working and blind spot areas

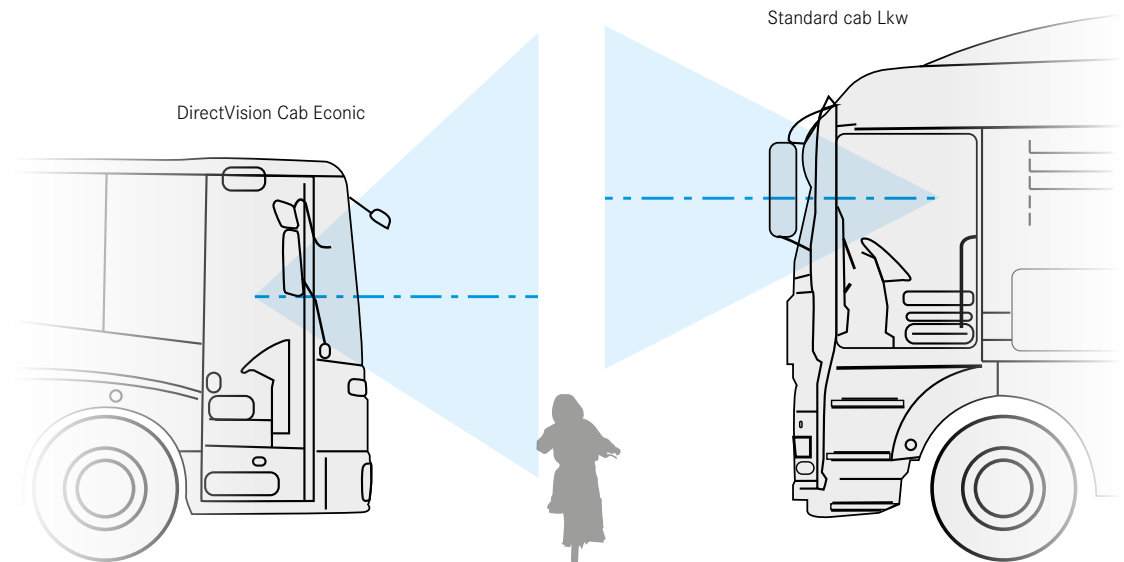

Packed with intelligent solutions: the Eonic with DirectVision Cab. For better visibility. And safety.

Make the switch to low entry. In a couple of easy steps.

Occupational safety at every step and turn.

With employee protection being of significant importance, the entrance has been made lower – a solution which enhances both ergonomics and safety in equal measure. The low entrance with just two steps also speeds up work processes, especially on multi-drop work. Thanks to convenient through-cab access, the driver can also get in and out of the vehicle on the passenger side – using the inward-opening folding door. A practical feature that also helps to prevent accidents.



- Low entrance with just two steps
- Entry and exit on the passenger side via the folding door
- All-round air suspension for a smoother ride
- Vehicle lifting and lowering function on both axles
- Choice of high or low cab to suit application

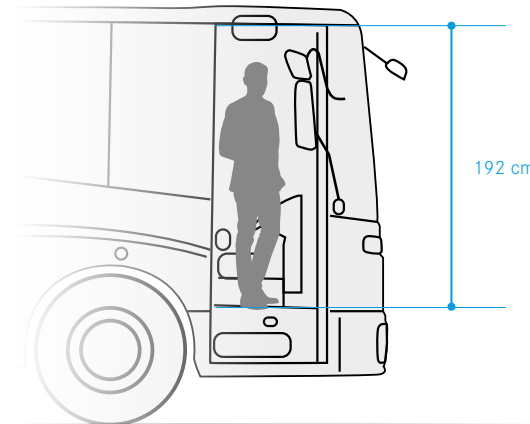

Standing up to the task:
comfortable in-cab standing height.



Two steps for improved ergonomics: the low-entry design of the Eonic makes getting in easier and getting out safer.

Not just a view. But an overview.

100% attention. Intelligent systems for maximum safety.

When it comes to anticipatory driving and prevention, the Econic is a decisive step ahead of conventional trucks. This is thanks in no small way to the low seating position and panoramic cab windows. But it's also due to the fact that the Econic has multiple safety systems on-board. With their cameras, sensors and additional lighting systems, they ensure that the driver can focus on what's important. Even in situations that demand maximum attention, such as in heavy traffic around town, when turning off, manoeuvring and reversing, or when encountering the end of a tailback.



- Co-ordinated safety assistance systems available
- Specially designed for urban use
- Imaging systems and sensors complement each other effectively
- Relieve the strain on drivers in hazardous situations



Observe and react.

The safety systems at a glance.

A comprehensive package of safety assistance systems helps the Econic driver to maintain an overview in critical situations.

- On an ergonomically located monitor, the **Blind Spot Camera System*** displays images of the vehicle's surroundings that are specifically relevant to the current driving manoeuvre. When reversing, manoeuvring and turning, therefore, drivers have everything they need in view at all times.
- The sensor-assisted emergency braking system **Active Brake Assist**, which is installed as standard, issues a warning when there is a risk of a collision. If the driver fails to respond to the visual and audible warnings, automatic partial braking is initiated, accompanied by activation of the hazard warning lamps. This is followed by an application of the brakes at maximum braking power. Available with pedestrian detection* as an option.
- **Sideguard Assist*** detects people on the passenger side and alerts the driver by means of a warning light. If the driver disregards the warning and turns the vehicle towards the detected person, a warning signal sounds. For safe and stress-free driving.
- **Adaptive cruise control*** monitors the distance from the vehicle ahead and automatically adapts the speed of the Econic.
- A **rain and light sensor** and **Lane Keeping Assist** are part of the standard package. The pre-installations for **reversing assist***, a **speed limiter when reversing*** and **automatically activating hazard warning lamps*** are available as options.
- **Work lamps*** help to illuminate the manoeuvring area behind the vehicle and the area around the vehicle body. This significantly improves work safety during night-time operations.

* Optional equipment

More information on the Econic safety assistance systems can be found in a series of videos at:

➤ mbs.mercedes-benz.com/safety-systems

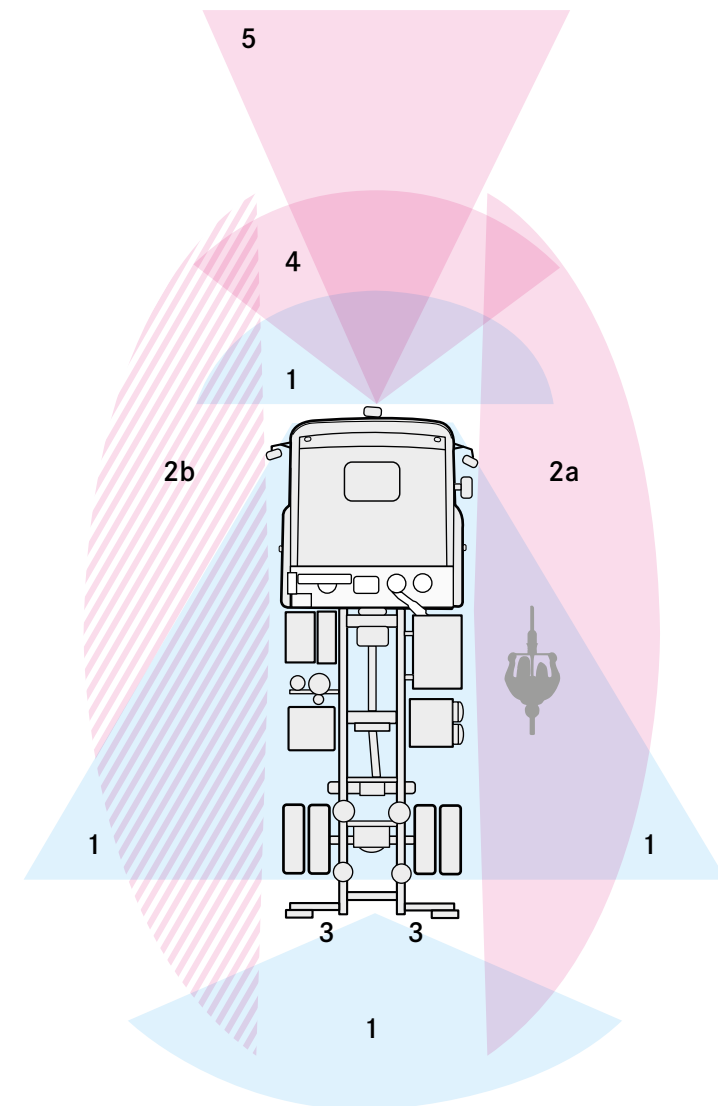

- | | |
|---|-----------------|
| 1 Blind Spot Camera System | Imaging systems |
| 2a LHD Sideguard Assist | Sensor systems |
| 2b RHD Sideguard Assist | |
| 3 Pre-installation for reversing assist | |
| 4 Active Brake Assist | |
| 5 Adaptive cruise control | |

Designed for an ordinary day. But by no means ordinary.

Sophisticated cab design for enhanced comfort.

All functions of the Econic are driver-focussed: to assist the driver and make a strenuous working day as pleasant as it can be. Helping to make this possible are the comfortable in-cab standing height and the luxury suspension seat. A powerful air-conditioning system together with tinted glass and a sunblind ensure pleasant temperatures whatever the weather.





Room for productivity.

No matter what jobs you have planned for the Econic, its spacious cab provides plenty of room to move about in, whilst its sophisticated design creates the best-possible working environment. If the job requires it, there is room for up to three co-drivers. Ideal for frequent stops: when driving off, the folding door on the passenger side closes automatically. Depending on intended use, a hinged door can also be installed.



The champion of multi-tasking.

Clear displays and intuitive instruments ensure that the driver quickly feels at home in the cockpit. The high-performance engine brake, for example, is very easy to activate with the right-hand multifunction lever. Radio, telephone and instrument cluster are conveniently operated via the multifunction steering wheel. Likewise, the controls for the bodies and attachments can be easily integrated into the cockpit - enabling the driver to monitor important functions directly from the cab.



Eyes forward.

The instrument cluster and state-of-the-art display ensure that the driver can access all important vehicle information quickly. Centrally located displays for the optional imaging safety systems allow the driver to view camera images from all around the vehicle. To protect from glare, the electric roller sunblind can be lowered as far as the exterior mirrors if the cameras are being used.



A place for everything.

Two lockable stowage compartments provide the crew with plenty of stowage space. Additional stowage compartments, along with bottle and cup holders in the dashboard also provide space for personal items or tools.

Clean and economical in one breath.

Innovative diesel and gas engines for the Eonic.

Delivering full power – as ecologically and frugally as you could possibly wish for. A task which the Eonic manages effortlessly regardless of where it is being deployed.



- 6-cylinder diesel engines with outputs from 200 kW (272 hp) to 260 kW (354 hp) or gas engine with output of 222 kW (302 hp)
- Max. torque from 1100 to 1400 Nm
- Volume-production proven engines with 7.7 l displacement
- Allison 6-speed automatic transmission or PowerShift semi-automated gearshift
- Powerful premium engine brake for higher braking effect and reduced brake wear



The modern OM936 diesel engine is available in three power variants ranging from 200 kW to 260 kW.

Proven powertrain technology. Euro VI diesel engines.

The Eonic is equipped as standard with a BlueTec 6 diesel engine and innovative catalyst technology that reduces particulate matter and oxides of nitrogen to a minimum. The engines deliver plenty of torque, even at low engine speeds, whilst also optimising fuel and AdBlue consumption. Full power that pays off.

The powerhouse with a green heart. The Econic NGT.

With its pioneering gas engine, the Econic is a worthwhile investment for more and more municipal authorities. It can be run on natural gas and biogas in compressed form. As a result, it is effective in reducing operating costs as well as particulate matter and noise emissions. With the optional natural gas drive system, CO₂ emissions can be reduced by a further 20% – without the need for an SCR catalytic converter, particulate filter or AdBlue. A green light to work in environmental zones.

At 80 dB(A), the noise levels of the powerful and reliable 7.7 litre gas engine are below the legal requirements. The weight-optimised steel/composite gas tank ensures the vehicle has a long range whilst also increasing the payload. The long service intervals reduce repair and maintenance costs. There are also savings to be had in terms of tolls and taxes and there is a reduced risk of being prohibited from entering certain areas. Good for your company and the environment.

For more on the Econic with gas engine, please visit:

mbs.mercedes-benz.com/ngt-drive



Now even quieter and with fewer emissions: the innovative M936G gas engine with a power output of 222 kW (302 hp).

The right transmission for every job.

The Allison 6-speed automatic transmission with intuitive gearshift logic is wear-free. And makes life easier for the driver at the same time. The practical crawler function allows the vehicle to move off with greater precision and is ideal for use in the waste management sector. For an even more efficient drive, there's the option of the PowerShift semi-automated transmission. The weight-optimised transmission with 12 forward and 4 reverse gears has transmission programs that are specially configured for driving in towns.





Designed for town and driver.

The Econic in the waste management sector.

Refuse collection is one continuous round of negotiating early morning rush hour traffic, manoeuvring into narrow residential streets lined with parked vehicles and emptying dustbins and containers quickly. It's a vital part of our society. But it's hard work that requires great care, attention and strength. Which is why the Econic is specifically designed to make life easier. The low entry and exit reduces operator strain. The state-of-the-art cockpit, innovative assistance systems and the extended field of view provided by the panoramic windows and folding door enhance both driving comfort and safety. And in the cab, there's room for up to four people. No wonder, then, that experienced professionals are full of praise for their new workmate.

Low-emission refuse disposal with gas.

Society demands maximum mobility and flexible disposal concepts. But also clean air and a high quality of life. The Eonic manages this balancing act effortlessly. With efficient Euro VI diesel engines or the innovative natural gas drive system. The latter is exceptionally clean, quiet and economical. Ensuring unrestricted access to environmental zones. Day and night.

Find out why this Eonic NGT in Berlin is running on the fuel it helps to make:

> mbs.mercedes-benz.com/eonic-ngt-berlin-en



The most powerful force on the market.

Eonic, the mobile waste compactor at London's Lewisham Market.

Future-proof concepts are in demand in the municipal waste management sector. Worldwide. The versatile attachment and securing options make the Eonic an outstanding team player. In the London borough of Lewisham, the Eonic is a regular visitor to the local market. Six days a week, it works as a mobile waste compactor, disposing of huge amounts of refuse so quietly and cleanly that residents and visitors barely notice it's there. The reason for this: thanks to an electrohydraulic system, the Eonic, unlike conventional refuse vehicles, can switch off its engine when lifting containers and compacting waste. Lewisham's fleet management department is equally impressed with the low-entry concept and DirectVision Cab. Because, thanks to these features, the Eonic already meets the Direct Vision Standards that will come into force in London in 2020.

Read the whole story online at:

> mbs.mercedes-benz.com/lewisham-market-en



The Eonic is ideal for logistics operations in busy inner-city areas.

The future is coming. Safely.

Modern urban distribution transport with the Econic.

Our daily routine may include buying fresh fruit and vegetables from the organic market, ordering medicines for collection the same afternoon, or cycling to a favourite restaurant. Whatever we do, it is clear that the pace of life has increased. And with it the demands on urban distribution transport. It needs to be clean, efficient and cost-effective. And above all safe. Because it can be a tight squeeze on the streets. And this is precisely the place where the DirectVision Cab of the Econic comes into its own. Keeps the situation in view – and under control – at all times. Scores top marks with sustainable powertrain solutions. And delivers goods to their destination on time and without hassle.



Ensures peaceful nights.

Three out of four German consumers can envisage retail deliveries taking place at night.* To do so without causing annoying traffic noise requires new low-noise vehicle concepts. Like the Econic, which, when equipped with the gas engine, already meets, and indeed is better than, the legal requirement of 80 dB(A).

* Survey PwC, 2017: New ways for urban logistics



Fresh ideas for logistics.

The Econic as a mobile coolbox.

In the centre of Paris, just as in many other metropolises throughout the world, the Econic can be found working away safely and efficiently, delivering fresh produce to retail businesses in its specially manufactured refrigerated body. And the really ingenious feature: thanks to separate refrigeration systems, meat and vegetables can be stored at the optimum temperature.

In urban tasks, a high degree of safety is required at all times. The Econic makes no compromises: its DirectVision Cab keeps drivers in the picture at all times, as they are seated at eye level with vulnerable road users such as cyclists and pedestrians.

Read the whole story at:

mbs.mercedes-benz.com/econic-paris-en

Quick to arrive on the scene. Not its limits.

The Econic as a fire appliance.

As soon as the alarm sounds, every second counts. Which is why each operation is virtually second nature to the crews. The Econic ensures that no time is lost. Just two short steps make easy work of getting in and out of the vehicle. The Allison automatic gearbox saves gearshifting time and offers maximum driving convenience. And when manoeuvring through busy urban traffic and streets lined with parked vehicles, the low seating position and all-round glazing ensure that the driver has an overview of the situation at all times. For maximum safety and speed, even when the heat is on.



The low-entry concept with folding door allows fast, easy and effortless entry and exit – even with heavy equipment.



In the race against fire: ready for anything.

With its wide range of variants and body-friendly low-frame concept, the Econic can be put to a host of different uses: as the base vehicle for a turntable ladder, rescue platform or pump tender. In the vehicle, there is room for up to four crew members. Even when fitted with tall bodies, bridges and passageways are no obstacle for the low cab version of the Econic.



All fired up about the Econic.

The fire service in the Danish city of Haderslev values vehicle dynamics.

“The compact wheelbase makes the Econic extremely agile,” says firefighter Jens Fredskild. After all, on the journey to the scene of an incident, everything has to run like clockwork. And during night-time rescue operations, he can illuminate the entire operational area from the rescue platform 30 m up in the air, making life easier for the rescuers. Safety and speed go hand-in-hand in the Econic.

Read the whole story online at:

mbs.mercedes-benz.com/firefighting-econic

Building on safety.

The Econic on the construction site.

Our cities are growing. Worldwide. The Econic is right there every day. Complying already with tomorrow's safety standards. Because that's all part of its blueprint. From the panoramic window through to the folding door with full-height glazing on the passenger side: the direct view of the urban traffic conditions and the construction site is virtually unbroken. This benefits cyclists and pedestrians in particular. Because anyone who is seen more quickly and has eye contact with the driver can be avoided more easily.



As versatile as the construction trade.

Thanks to a variety of chassis variants and standardised body interfaces, the Eonic can be used for a wide range of applications. Compact, agile, as a concrete mixer or tipper, with or without a crane body and many more besides.



I see what you don't see.

DirectVision Standards and the Eonic make London safer.

In confusing urban traffic situations, any inattentiveness can have serious consequences. In cities, accidents are on the increase, particularly between conventional trucks and cyclists or pedestrians. Which is why the safety action group Construction Logistics and Cyclists Safety (CLOCS) has been founded in London, its objectives being to reduce the number of accidents involving trucks and define preventive measures. The result: from 2020 it will be mandatory for all trucks weighing over 12 tonnes to have a direct view of other road users. Because this is shown to shorten reaction time and stopping distance – and consequently helps to avoid accidents. The Eonic already complies with these DirectVision Standards now.

For more information on the Eonic in London traffic, please visit:

[➤ mbs.mercedes-benz.com/initiative-clocs-en](https://mbs.mercedes-benz.com/initiative-clocs-en)



With its scissor-lift body, the Eonic can dock directly into the aircraft cabin to deliver catering supplies or serve as a medical lift.

High flexibility – for seamless ground handling operations.

The Econic at the airport.

Numerous passengers, thousands of flights, countless processes, all of which must dovetail perfectly: flight operations are a logistical challenge. The Econic fits perfectly into the ground support team. The low cab can be manoeuvred under most aircraft wings. The location of the major assemblies behind the cab means that it can be easily equipped with a variety of bodies, thus making the Econic a useful team player anywhere. Whether it be for refuelling, for delivering catering supplies or with the scissor-lift body as a medical lift for wheelchair users or recumbent transport. To ensure airlines are successful above the clouds, they need fast solutions on the ground. Thanks to the standard-fitted automatic transmission, drivers can give their full attention to what's going on around them. The panoramic window keeps everything in their view. Aircraft, ground handling vehicles, employees. A professional amongst professionals.



Safely supplying aircraft with fuel: the Econic with tank body.



Sky-high cuisine.

Catering with the Econic at Vienna Airport.

The drivers at the Austrian capital's airport deliver fresh food directly to the aircraft. They appreciate the low-entry concept of the Econic as it provides easy entry and exit and excellent visibility. An additional bonus is the blind spot camera system which ensures all-round visibility. Incidentally, the environmentally friendly gas engine in the Econic NGT reduces air pollution on Vienna airport's runways.

Read the whole story online at:

mbs.mercedes-benz.com/vienna-airport

Flexibility as standard.

Tailor-made Econic for every job.

With a choice of low or high cab, diesel or gas engine, four different axle variants and wheelbases ranging from 3450 to 5700 mm, the Econic is perfectly suited to a wide variety of sectors and tasks. But it wouldn't be a Mercedes-Benz truck, if it didn't go the extra mile to cater for special requirements. At Mercedes-Benz Custom Tailored Trucks (CTT), it's not just the usual high-quality volume production operations that are all part of a day's work, there are also complex conversion projects and individual solutions, ranging from the relocation of individual components through to highly complex axle conversions. You'll receive series-production construction standards tailored entirely to your needs.



- Body-friendly low vehicle frame
- Possible to install low bodies/attachments
- Gross vehicle weight from 18 to 32 tonnes
- Development and design from a single source
- Mercedes-Benz warranty and service
- Consultancy and care from qualified personnel – right through to the provision of registration documents
- Network of skilled conversion partners



Adapted for below ground.

The Econic at the Werra potash mine.

750 metres underground, the Econic is hard at work day after day in the underground re-utilisation facility at the Werra plant of the K+S potash mining company. At the site in Hattorf, already excavated areas are made safe with backfill material obtained from mineral production waste. 16 sacks, each weighing around 1.2 tonnes, are loaded onto the low loader of the Econic, which then transports the backfill material over the bumpy salt tracks to the old potash chambers. "We have to tackle inclines of up to 14% while carrying just under 20 tonnes of materials. That's only possible with a true powerhouse like the Econic 1835," explains works manager Arnd Schneider. The semitrailers needed for the job were custom-made for use in the mining galleries which are less than three metres high. And that for each of the 13 Econic trucks in operation so far in Hattorf.

Read the whole story online at:

mbs.mercedes-benz.com/werra-potash-mine

Powerful In all things service, too.

Mercedes-Benz quality and reliability.

The Econic is built in the largest truck plant in the world. In Wörth, more than 11,000 employees work towards one goal: to make Mercedes-Benz commercial vehicles even better. Every day. Without compromise. The strict production standards and test cycles meet the highest of quality demands. And the same applies to our sales and service operations.



Financing.

At Mercedes-Benz, you can be sure that not just your vehicle is perfectly tailored to your needs but your financing arrangements too.

mbs.mercedes-benz.com/financing



Service nearby.

With over 1800 Econic service outlets in more than 130 countries, we make sure that you are back on the road quickly.

mbs.mercedes-benz.com/find-service-partner



The Econic – just one click away.

Information, stories, service. Explore the Econic and its innovative low-entry concept in MBS World.

mbs.mercedes-benz.com



Please note: changes may have been made to the product since this publication went to press (17.01.2019). The manufacturer reserves the right to make changes to the design, form, colour and scope of delivery during the delivery period, provided that these changes, whilst taking into account the interests of the vendor, can be deemed reasonable with respect to the purchaser. Where the seller or the manufacturer uses symbols or numbers to describe an order or the subject of an order, no rights may be derived solely from these. The illustrations may show accessories and items of special equipment which are not part of standard specification. Colours may differ slightly from those shown in this publication, owing to the limitations of the printing process. This publication may contain models and services which are not available in certain countries. Information given regarding statutory regulations, legal requirements and taxation and the consequences thereof applies to the Federal Republic of Germany only and is correct at the time of going to press. To find out about the current status of these regulations and their implications, please ask your Mercedes-Benz partner.

www.mercedes-benz-trucks.com/econic-en