

Gyrorakes

GA SINGLE-ROTOR RAKES



www.kuhn.com



be strong, be **KUHN**



GA

300 M

3201 G

3201 GM

3801 GM

4121 GM

4321 GM

4431

4731

5031

4731 T

5031 T

HIGH QUALITY MANUFACTURING CERTIFIED BY THE WORLD LEADER

GENTLE, HIGH-QUALITY RAKING NEEDED

KUHN, the pioneer in rotary rakes with guided arms, ensures with features such as the double-curved hyper-tangential tine arms that all forage is raked according to your satisfaction.

HOW TO INCREASE PERFORMANCE WHILE REDUCING MAINTENANCE COSTS

The exclusive MASTERDRIVE gearbox is very robust and will cope with any kind of crop and condition thanks to its patented design for an increased service life.

KEEPING OPERATING COSTS LOW

Saving time means reducing the production costs. How to achieve that? KUHN offers machines, with which you can work fast without having to accept restrictions in raking quality or driving stability on headlands and slopes.

KUHN mounted and trailed single-rotor Gyrorakes in brief:

	Working width (m)	Power requirement (kW/hp)	Windrow delivery
GA 300 GM	3.20	15/20	left
GA 3201 G	3.20	15/20	left
GA 3201 GM	3.20	15/20	left
GA 3801 GM	3.80	19/25	left
GA 4121 GM	4.10	22/30	right
GA 4321 GM	4.20	22/30	right
GA 4431	4.40	23/30	right
GA 4731	4.65	26/35	right
GA 5031	5.00	30/40	right
GA 4731 T	4.65	26/35	right
GA 5031 T	5.00	30/40	right



NO NEED TO CHOOSE BETWEEN CLEAN RAKING AND CLEAN CROP

Uniform and fluffy windrows are a prerequisite for easy pick-up by balers and quick drying. To achieve this KUHN has respected the following basic requirements for an ideal forage delivery:

- tine arms with positive forward angle until the point at which it delivers the forage on the windrow,
- fast tine raising in very last moment before going over the windrow.

Discover KUHN's assets to achieve superb windrows that let air and sunlight in for faster drying, while providing clean forage.

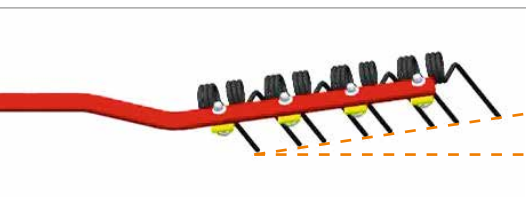

IMPROVED WINDROW FORMATION

On GA rotary rakes, tine arms are not only positioned tangentially, but hyper-tangentially (except GA 300 GM and GA 3201), meaning that they reach a 90° angle towards the windrow very late. Together with the steep cam track of the tines, this means that the tines can be raised much quicker with less distance to cover. This delayed raising is ideal for forming even more regular, fluffy and straight windrows and provides high quality raking at high speeds (no crop pulled out of the windrow).

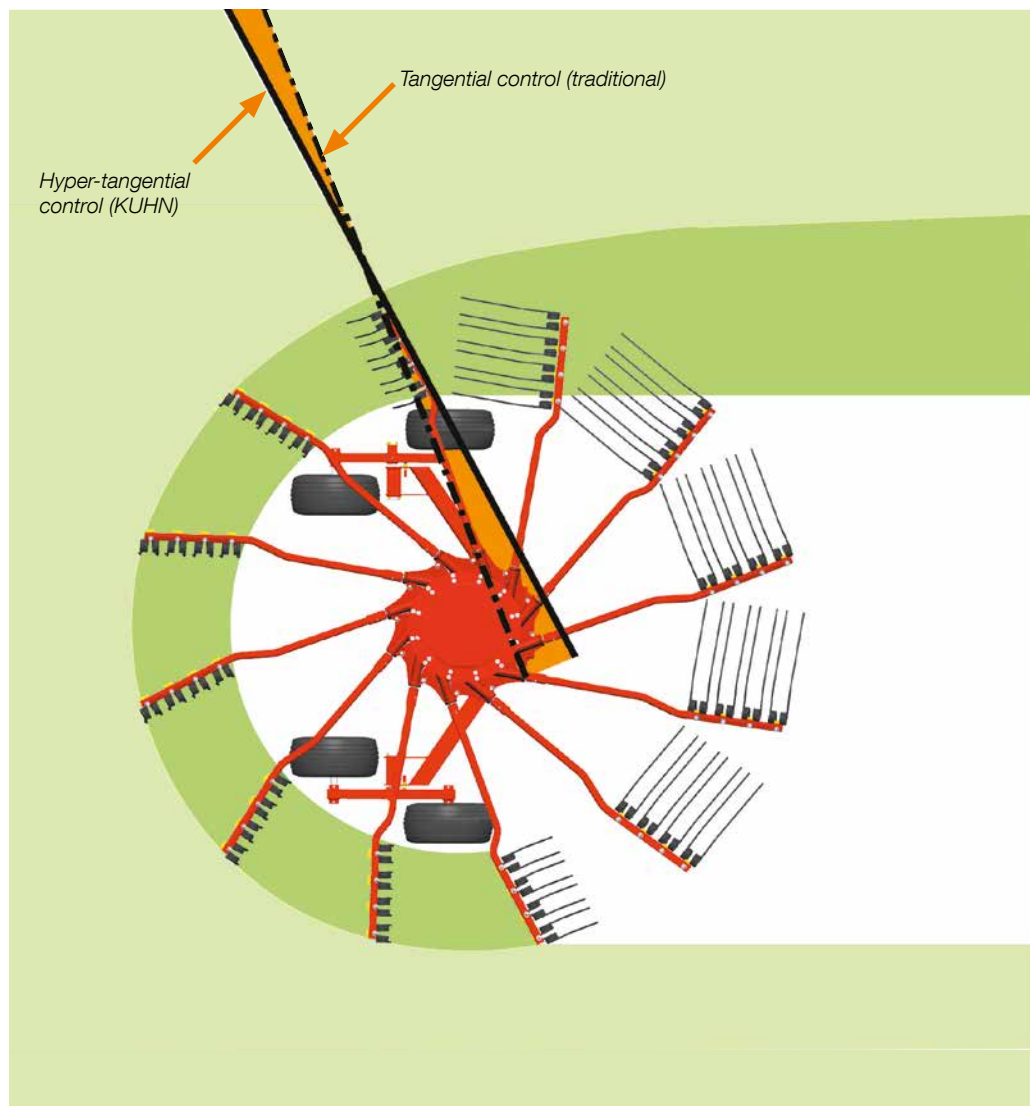

MORE STRONG POINTS OF DOUBLE-CURVED TINE ARMS:

- 1) They also reduce the distance between tine passages. So there is less risk of forage being left unraked. Losses are reduced to a minimum, also at high working speeds.
- 2) The centre of the tine arm mass is exactly at the centre of the tine arm. This is especially beneficial for a long service life, because there is no leverage during the tine arms' rotation. The cam followers are thus less exposed to stress.



TINES WITH BENEFITS

KUHN tines rake the crop especially gently, also if it is heavy and dense. Made of heat treated steel, their service life is optimized and the tine's resistance to fatigue increased. The "floating" attachment of the tines, featuring three large-diameter coils, additionally reduces risk of wear. Simultaneously the tine height is accurately controlled to preserve both the stubble and the crop.



OPTIMUM WHEEL POSITION

The wheels are positioned extremely close to the rotor. Therefore, the tines follow ground contours better to avoid impurities in the forage.

KUHN PATENT

A WINDROWING SYSTEM INTELLIGENT AND ADJUSTABLE FOR EVERYONE

The windrow deflector arm is mounted on a parallelogram frame for models starting from GA 3201. For its adjustment you simply turn a handle or comfortably set it from the tractor cab via a hydraulic cylinder. When extended outward the screen automatically moves to the rear, when retracted it moves to the front. This is very practical because in this way it is always correctly placed in relation to the crop trajectory.



CROSS-SECTION MASTERDRIVE GEARBOX

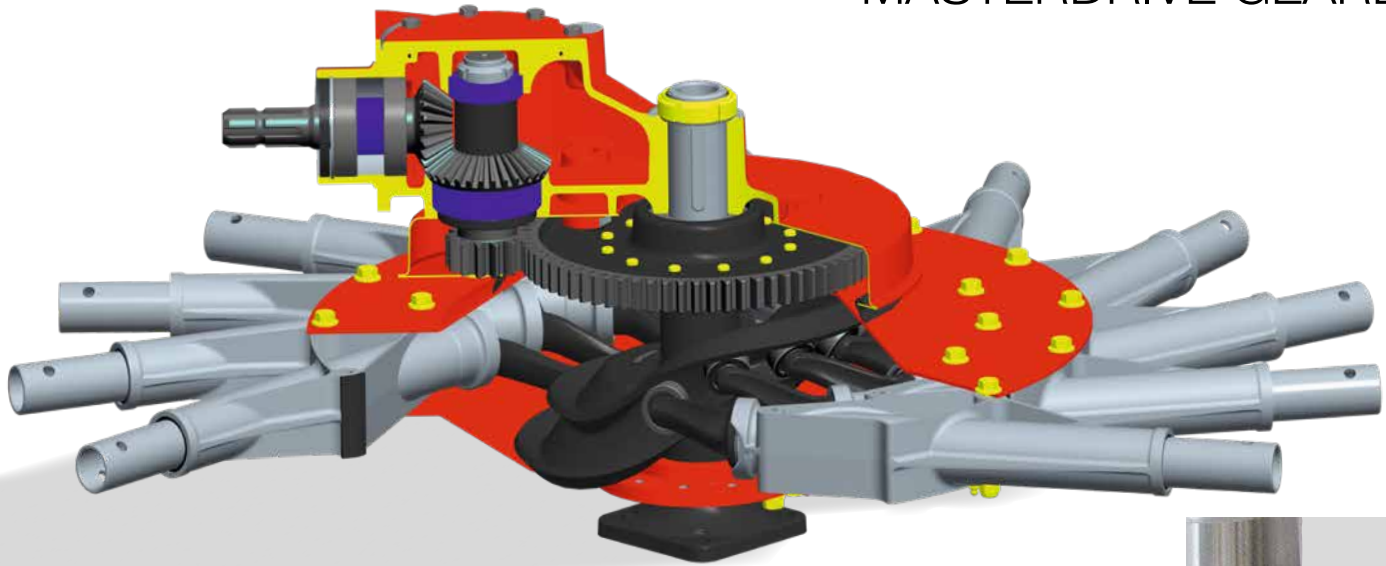

No tilting or tolerance possible when driving over uneven ground

THE GEARBOX TO COPE WITH MAXIMUM STRAINS

Rotor drive is put under high pressure from raking operations. KUHN has developed fully enclosed gearboxes for total protection of the drive parts and reduced wear.

The MASTER DRIVE gearbox is particularly appreciated for its special design which is exceptionally reliable and durable, even during intensive operations.

KUHN PATENT

The MASTERDRIVE gearbox reveals an exclusive design with its two-stage, reduction drive using bevel and “bull gear” reduction. Tolerances in the bevel reduction are thus tightly controlled for more reliability and an increased robustness of the whole assembly in difficult conditions.

Therefore, wear on the gearwheels is reduced to a minimum and almost no maintenance required. The two stages also make it possible to include bigger bull gears with more teeth for better power transmission.

	Fully enclosed single-stage gearbox	Double stage MASTER DRIVE	Double stage MASTER DRIVE GIII
GA 300 GM	◆	-	
GA 3201 G	◆	-	
GA 3201 GM	◆	-	
GA 3801 GM	◆	-	
GA 4121 GM	-	◆	
GA 4321 GM	-	◆	
GA 4431	-	-	◆
GA 4731	-	-	◆
GA 5031	-	-	◆
GA 4731 T	-	-	◆
GA 5031 T	-	-	◆

The MASTER DRIVE GIII, available on most of our double-rotor rakes, was developed for the most intensive operations. The rotors are lighter and even more reliable, with more robust arm attachment.

STABLE UNDER ALL CONDITIONS. QUICK AND HIGH-QUALITY WORK.

The nutritional quality of the forage is most important for high feeding performance, but don't forget to keep your operating costs low. Working quickly without restrictions regarding work quality is the key to further reduce production costs. KUHN's GA Gyrorakes feature important details to support you in your effort.



MOUNTED FLEXIBILITY WITH TRAILED PERFORMANCE

Most KUHN windrowers are available with a pivoting headstock (all except GA 3201 G) and are as efficient as a trailed machine. With nearly 50°, this coupling head offers the widest swivel angle on the market. Thus, working in bends does not alter the raking quality or the shape of the windrows. What's more, the baler will be easier to handle in the corners.



QUICK AND EFFICIENT

If you would like to optimize your forward speed, raking quality, preserve ground cover and protect the machine against wear and tear of uneven terrain, KUHN has another important asset to offer. The bogie axle with four staggered wheels adapts well to ground contours and cares for an increased output thanks to stabilizing the machine.



STABLE ON SLOPES

Some of our single rotor models are equipped with one or more headstock dampers to improve stability on slopes. When lifting the rotor, the damper automatically and smoothly centers the headstock behind the tractor. Benefit from a damper as standard on the GA 4321 GM, and as option on the GA 3801 GM and GA 4121 GM. The new GA 4431, GA 4731 and GA 5031, in mounted version are fitted as standard with two side dampers.



GA 300 GM

PROVEN RELIABILITY FOR SEVERAL DECADES

As KUHN is the inventor of rotary rakes, the GA rakes have always been considered as the “Gyorakes”. The 3-point mounted GA 300 GM, from today’s point of view a pioneer KUHN Gyorake, is no exception to this rule. With this simple rake you can harvest a crop rich in leaves and full of essential nutrients.



NO MAINTENANCE REQUIRED

The tine arm drive components are housed in a fully enclosed gear case, and don't require any special maintenance. For additional robustness, the tine arm holders are fixed on both the upper and lower gear case covers.



Cross-section GA 3201/3801 gearbox:
fully enclosed single-stage bevel gear

NO COMPROMISES IN RAKING QUALITY

The nine tine arms of the GA 300 GM follow a cam profile that provides high clearance over the windrow. The pivoting headstock allows an increased manoeuvrability and improved terrain following. All this ensures the formation of even, fast drying windrows that are free of stones, even around corners.



GA 3201 G 3201 GM 3801 GM

FULLY EQUIPPED FOR LOW AND MEDIUM HORSEPOWER TRACTORS

The GA 3201 and GA 3801 GM are the right machines for farms with less hectares and low or medium horsepower tractors. Equipped with nine and ten tine arms respectively, these rakes work 3.20 m (10'6") and 3.80 m (12'6") wide.

STRONG POINTS

- high number of tine arms and tines per arm for even better raking
- hypertangential design of tine arms on GA 3801 GM: very competitive compared to machines with an additional tine arm or more tines per arm
- fully enclosed greased gearbox
- parallelogram-mounted windrow deflector: moves systematically into the best position, windrow width adjustable without tools
- easily detachable tine arms for reduced transport width
- guards and windrow curtain easily folded up for transport and storage thanks to a spring



GA 3201 G: IDEAL FOR STEEP SLOPES

With a fixed attachment to the tractor the rake will faithfully follow the tractor on the steepest slopes. It is fitted with pivoting wheels. The machine height is adjusted by a lever located on the wheel.

GA

4121 GM

4321 GM

WHEN RAKING OPERATIONS GET MORE DEMANDING

When conditions get more difficult and working widths are increasing, you as farmers demand more robust machines. KUHN answers with the exclusive MASTERDRIVE gearbox for larger models, as the GA 4121 GM with 4.10 m (13'5") and the GA 4321 GM with 4.20 m (13'9") working width.

FOR AN IMPROVED PERFORMANCE

These rakes feature three important advantages for improving, economizing and accelerating your forage harvest: large working widths - fast working speeds - high manoeuvrability thanks to the pivoting headstock.



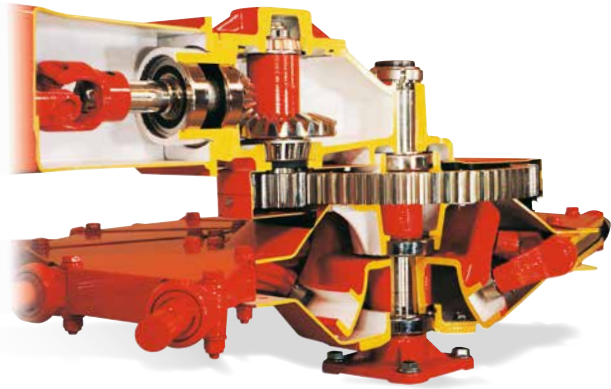

MASTER DRIVE

Fully enclosed gearbox – two-stage reduction drive – increased robustness, reliability and service life – improved power transmission

THE EASE OF FOLDING

Thanks to a spring, the left guard and windrow deflector can be easily raised and lowered.

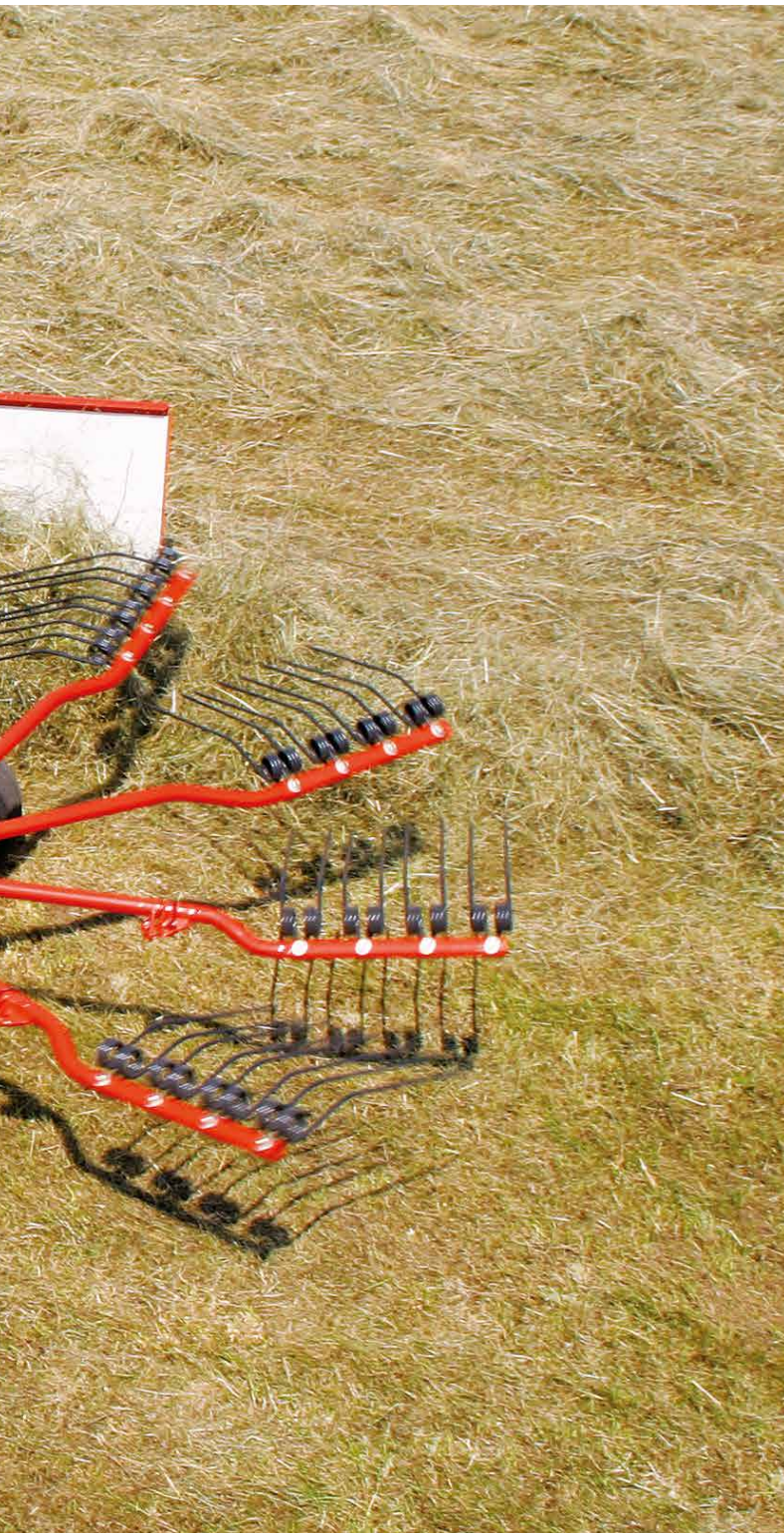

HOW TO ACHIEVE IMPECCABLE RAKING

The greater number of tine arms allows working at higher ground speeds while maintaining a slower rotor speed. This ensures that the crop is raked both cleanly and gently. The double-curved design of the tine arms increases capacity and enables optimum raking of the crop. This results in well formed, airy windrows that decrease drying time and improve the feeding capacity of the following baler.



WINDROW DELIVERY TO THE RIGHT

From a practical point of view delivering the windrow to the right is a must. Don't underestimate the additional comfort of being able to monitor the raking quality and to do all necessary adjustments at the same time, as you find both the windrow and the operating panels on your right side.



GA 4431 4731 4731 T 5031 5031 T

EVERYTHING A LARGE MODEL HAS

Choose these rakes for their reliability equivalent to our large-width rakes with twin or 4 rotors. They have the same MASTER DRIVE GIII gearbox adapted to the most intensive uses!



GENERATION III: MORE RELIABLE, LIGHTER

Increasing working widths and rotor diameters combined with difficult raking conditions (silage, haylage), drove us to offer more robust drive components, even on single-rotors.

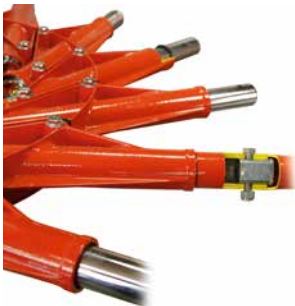

EXCLUSIVE
NEW TINE
FIXATION
FOR MORE
ROBUSTNESS

DESIGNED TO LAST

Important features have been changed to produce lighter, yet more robust rotors:
 Arm support bearings in aluminium and individually removable.
 Optimised cam track – less force on the tensioner – reduced rotation speed and pressure on the cam.
 Reinforced swing shaft.
 Reinforced tine-arm mount on swing shaft (patented bolted insert).



FORM WINDROWS, AND KEEP THEM NEAT!

With the lift system (mounted version) or the single acting control valve (trailed version) you can reach windrow clearance heights of:
 Over 40 cm with mounted machines.
 Over 50 cm with trailed machines.



LESS EFFORT AND LESS TIME

These gyrorakes were designed with new, more ergonomic arm support and centralised locking. Windrow curtain and guards can be deployed hydraulically (optional equipment) or manually, very easily, thanks to a weight compensation spring that saves you time and a lot of effort. It's practical and easy for working in plots split by roads. On both single-rotor versions (mounted and trailed), raking height can be adjusted easily with a crank handle.





QUALITY-CALIBRATED WINDROWS

The double-curved hyper-tangential tine arms ensure straight, regular windrows. Forage is guided into place and never picked up again accidentally by one of the coils thanks to rapid tine clearance, at a right angle and at the last minute. The windrow curtain mounted on parallelogram is easily adjusted in order to perfect calibration.



AT HOME ON SLOPES

Benefit from the stability of single-rotors on hilly and sloping ground. The mounted version has two side dampers with excellent machine-recentering capabilities. The headstock with 48° turning radius and bogie axle as standard, make this machine ideal in terms of manoeuvrability. The trailed version's bogie axle has four 18" diameter wheels to ensure faultless output, even on difficult terrain.

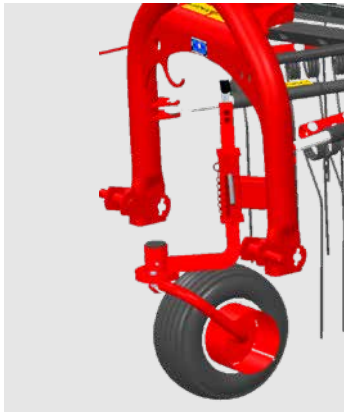
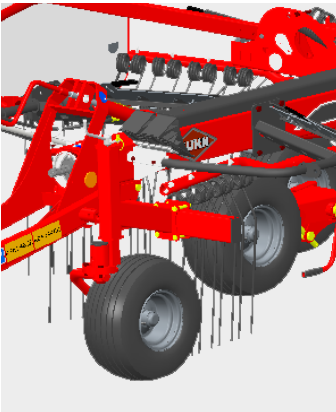

TO MAKE YOUR LIFE EASIER

On very hilly terrain, but also for easier hitch adjustment and thus time savings, choose the optional pivoting support wheel (mounted version).



EXCLUSIVE

MOUNTED MACHINE: INEVITABLY HIGH OUTPUT

The GA 5031 is the biggest single-rotor on the market. With a 4-meter diameter rotor for a 5-metre working width, it rakes faster than any other existing single-rotor!



TRAILED MACHINE

Coupling your single-rotor gyrorake to a 50hp tractor is no problem. Linkage is by drawbar and the whole combination requires very little power to work. One single acting hydraulic valve is enough to trigger the lift system at the end of the plot.

	GA 300 GM	GA 3201 G	GA 3201 GM	GA 3801 GM	GA 4121 GM	GA 4321 GM	GA 4431	GA 4731	GA 5031	GA 4731 T	GA 5031 T
Working width (m/ft)	3.20/10'5"			3.80/12'6"	4.10 / 13'5" (right window)	4.20 / 13'9" (right window)	4.40 / 14'5"	4.65 / 15'3"	5.00 / 16'5"	4.65 / 15'3"	5.00 / 16'5"
Average windrow width (m/ft)	Approx. 0.80 / 2'6" according to setting	Approx. 0.80 / 2'6" - 1.00 according to setting		Approx. 1.00 / 3'3" - 1.30 / 4'3" according to setting	Approx. 1.30 / 4'3"	Approx. 1.40 / 4'7" according to setting	0.70 - 1.50 / 2'3" - 4'9"				
Raking deflector	Windrow screen	Windrow curtain									
Width (m) – tine arms removed/in place	- / 2.75 / 9'	1.75 / 5'7" / -				1.95 / 6'4" / -	2.25 / 3.75 - 7'3" / 12'3"	2.45 / 4.00 - 8' / 13'1"	2.75 / 4.35 - 9' / 14'3"	2.31 / 4.00 - 7'6" / 13'1"	2.75 / 4.35 - 9' / 14'3"
Unfolding and folding of guards	-			Manual		Manual as standard – Hydraulic as an option					
Windrow curtain opening adjustment	-			Manual		Manual as standard – Hydraulic as an option					
Number of rotors / Rotor diameter (m/ft)	1 / 2.64 - 8'6"			1 / 2.98 - 9'8"	1 / 3.20 - 10'5"	1 / 3.40 - 11'1"		1 / 3.65 - 11'10"	1 / 4.00 - 13'1"	1 / 3.65 - 11'10"	1 / 4.00 - 13'1"
Number of tine arms per rotor / Number of tines per arm	9 / 3			10 / 4		12 / 4		13 / 4	15 / 4	13 / 4	15 / 4
Tine arms	Fixed	Removable									
Gearbox	Enclosed				Enclosed - Double stage- MASTER DRIVE		Enclosed – Double stage MASTER DRIVE G III				
Bogie axle	-			◇		◆					
Wheels	Fixed	Pivoting	Fixed								
Height adjustment	By scale						By crank				
Tyres under rotors	15 x 6.00 - 6			16 x 6.50 - 8					18 x 8.50 - 8		
Primary PTO shaft	-						With torque limiter			Wide angle for tractor + torque limiter	
Linkage	3-point - Cat. 1 and 2					3-point - Cat. 2			Drawbar with parallelogram		
Headstock	Pivoting	Fixed	Pivoting								
Headstock suspension	-				◇	1 as standard - 2 as option	◆			-	
Min. PTO power requirement approx. (kW)	15			19	22		23	26	30	26	30
Min. PTO power requirement approx. (hp)	20			25	30		35	40	35	40	
Necessary tractor hydraulic equipment	-									1 SA	
Lighting and signalling	-				◇					◆	
Approx. weight (kg/lbs)	286 / 630	347 / 765	372 / 820	474 / 1045	540 / 1190	702 / 1547	724 / 1596	750 / 1653	812 / 1790	820 / 1807	860 / 1896

◆ Standard ◇ Option - Not available

KUHN SERVICES* Maximize the use and productivity of your KUHN equipment

* Not all services and equipment are available in every country.

KUHN sos order

Express spare parts service 24/7

You urgently need spare parts? With KUHN SOS ORDER benefit from express delivery seven days a week, 365 days a year. Thus, you can minimize machine downtime considerably and increase your work output.

KUHN protect +

The choice of professionals!

Benefit from 36 months in complete serenity because of KUHN's PROTECT + warranty. You can concentrate exclusively on your work and the performance of your machine. Because this is what you expect, when investing in high-tech machinery.

KUHN i tech

For ever quicker repairs!

An unexpected technical problem always occurs at the wrong time. Your KUHN dealer can support you quickly and efficiently thanks to KUHNITECH. With this 24/7 online service, a quick and exact diagnosis is possible.

KUHN finance

Invest rationally!

New machine necessary, financing unsure? Modernize your equipment and develop your farm with KUHN FINANCE, in total safety and according to your needs and demands. We offer custom-made finance solutions, adapted to your requirements.

KUHN

APPS

SMALL PROGRAMS WITH GREAT IMPACT



FOR A POWERFUL FORAGE HARVESTING CHAIN

The forage harvesting chain is only as strong as its weakest link. It's important that all machines do well interlock. In this context, the KUHN ForageXpert app can support you in optimizing your harvest system according to your current equipment. With this tool you can quickly find the mower, mower conditioner, tedder and rake that are best adapted to your existing forage machines. Available on the Apple Store as well as Google Play.



Scan this code to directly access the KUHN ForageXpert app.



SINGLE ROTOR GYRORAKES

	GA 300 GM	GA 3201G	GA 3201GM	GA 3801GM	GA 4121GM	GA 4321GM	GA 4431	GA 4731	GA 5031	GA 4731 T	GA 5031 T
Suitable for steep slopes	+	+++	+	+++	+++	+++	+++	+++	+++	+++	+++
Management of heavy and wet forage	+	++	++	++	+++	+++	+++	+++	+++	+++	+++
Ease of work monitoring	++	++	++	++	+++	+++	+++	+++	+++	+++	+++
Ease of windrow width adjustment	+	++	++	++	+++	+++	+++	+++	+++	+++	+++

+++ optimum ++ very good + good o suitable

Check out the other rakes KUHN has on offer



1. Semi-mounted twin Gyorakes with side delivery
2. Semi-mounted twin Gyorakes with central delivery
3. Trailed twin Gyorakes
4. Four-rotor Gyorakes
5. Belt mergers
6. Tedder-rake combinations

For more information about your nearest KUHN dealer, visit our website www.kuhn.com

Visit us on our YouTube channels

Your KUHN dealer

www.kuhn.com

KUHN S.A.
4 Impasse des Fabriques - BP 50060
F-67706 Saverne CEDEX - FRANCE

KUHN NORTH AMERICA, INC.
1501 West Seventh Avenue -
Brodhead, WI 53520 - USA

KUHN FARM MACHINERY PTY. LTD
313-325 Foleys Road - Deer Park, VIC,
3023 - AUSTRALIA

KUHN FARM MACHINERY (U.K.) LTD
Stafford Park 7 - GB TELFORD/
SHROPS TF3 3BQ

Information given in this document is only for information purposes and is non-contractual. Our machines are in compliance with regulations in force in the country of delivery. In our literature, and for improved illustration of certain details, some safety devices may not be in operating position. When operating these machines, these devices must be in position in accordance with the requirements indicated in the operator's manuals and assembly manuals. Respect the tractor gross vehicle weight rating, its lift capacity and maximum load per axle and tyres. The tractor front axle load must always comply with the regulations of the country of delivery (In Europe, it must reach minimum 20 % of the tractor net weight). We reserve the right to change any designs, specifications or materials listed without further notice. Machines and equipment in this document can be covered by at least one patent and/or registered design. Trademarks cited in this document may be registered in one or several countries.

Also find KUHN on