

RR4 CO 26.480



CO 26.480 EEV Coach Chassis

► Specification Data

ENGINEERED TO SAVE YOU MONEY ►



SPECIFICATION DATA

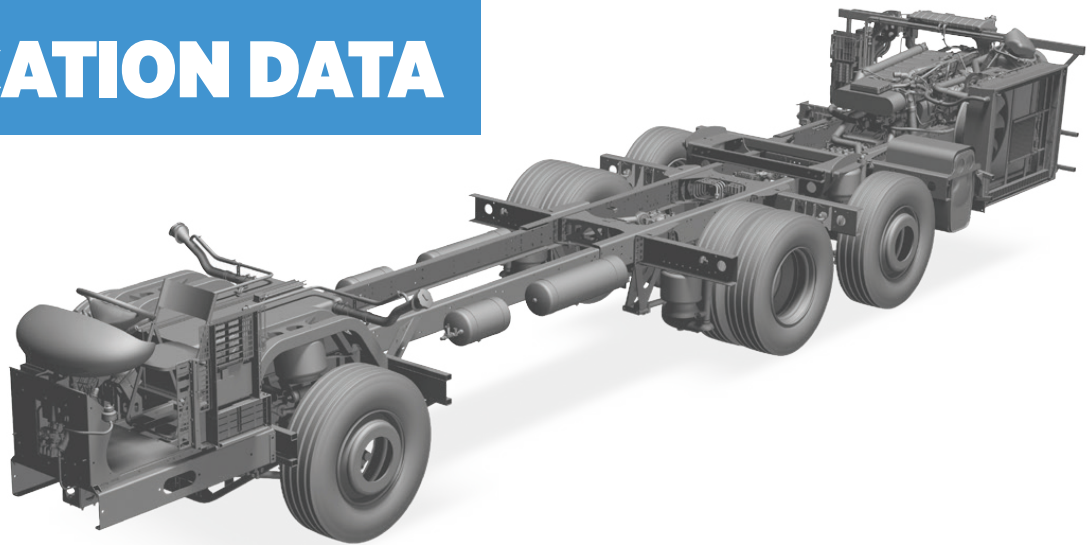

► ENGINE

MAN D26 upright turbocharged inline 6 cylinder.

EGR	Exhaust Gas Recirculation
Power output	353kW (480hp) @ 1,900rpm
Maximum Torque	2,300Nm at 950-1,400rpm
Bore	126mm
Stroke	166mm
Displacement	12,400cm ³

► CHASSIS

Frame	Straight Rail Modular
Front Overhang	2005mm temporary
Wheel Base	4500mm Transport Frame
Rear Overhang	1470mm + 3100mm
Transport Drivers seat only	
Front Axle	Independent suspension
Tag Axle	Electro-hydraulic steered tag axle
Brakes	Disc brakes on all wheels Electronic Braking System (EBS) Electronic Stability Program (ESP)
Wheels	8.25" x 22.5" Alloys standard
Tyre Size	295/80 R22.5

► PERFORMANCE

Geared Speed in km/h at 1,300 /1,900 rpm (electronically limited to 100 km/h).
Transmission ratio of ZF 12 AS 2301.

	1st	2nd	3rd	4th	5th	7th	11th	12th	Rev
Axle ratio: 3:36:1	12.33	9.59	7.44	4.57	2.7	1.63	1.00	0.78	11.41
1300 rpm	6	8	10	16	27	44	72	93	6
1900 rpm	8	11	14	23	39	65	106	136	9

► SUSPENSION

ECAS – Electronically Controlled Air Suspension.

No. of units	Front	Drive	Tag
Air bellows	2	4	2
Shock absorbers	2	4	2
Height control valves	1	2	
Stabiliser	1	1	

Constant entrance height and suspension characteristics under all load conditions.
Level Control: Raising/lowering.

► FUEL SYSTEM

Standard 480 litre tank, located in center above front axle. Dual Left and right filler.
'Separ' preliminary fuel filter with water separator.

► COOLING SYSTEM

Electronically controlled hydrostatic fan drive.
Left rear cooling package with hinged charge air cooler for ease of maintenance access.

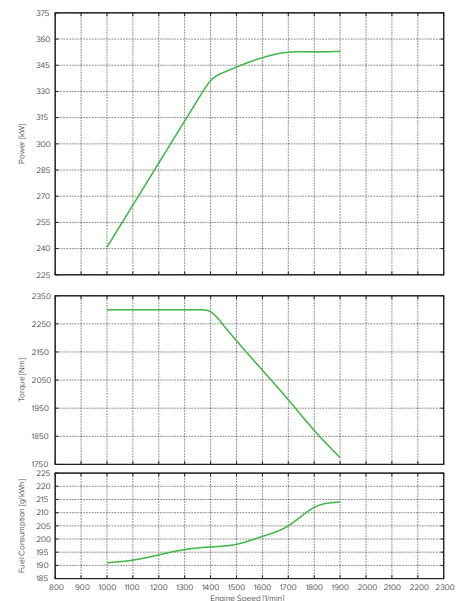

*Data in accordance with ISO 1585 88/195 EEC

NOTE: Information contained in this brochure was believed correct at the time of printing. Penske Commercial Vehicles reserves the right to change any detail in the specification sheet without notice. Penske Commercial Vehicles, as permitted by law, shall not be liable in any way as a result of any reliance placed by any person on details contained in this brochure. Some options may only be applicable to certain models. It is important that you confirm all specification with your dealer prior to ordering.

MAN Automotive Imports Pty Ltd
72 Formation Street, Wacol, QLD 4076 • PO Box 301, Goodna QLD 4300
T: (07) 3271 7777 • www.man.com.au

