



WESTERN STAR TRUCKS®





PROVEN DURABILITY

Designed to go the distance, the 4900 has a proven track record of reliability and performance. This durable truck comes into its own in road-train configurations, with a rating available of up to 160-tonnes (FXC model). With a long-standing American heritage, this tough truck not only boasts power under the hood, but also comes with an unsurpassed spacious full-width, roomier cabin making it the complete package.



LET'S GET SERIOUS



REST IN LUXURY

The Western Star ethos has always been centred around you, the driver. Getting behind a Star wheel has to be a pleasure. And when you step inside the roomy headquarters of a 4900, you won't want any other truck. This is where five star comfort meets practicality. Large doors, spacious floor, and double door seals that provide a quieter atmosphere in the cab. This is serious accommodation for a seriously powerful Star.



ROBUST & RELIABLE

Suitable for a range of applications, the 4900 is the specialist when it comes to road trains. You can count on this seriously durable truck to move your loads whatever the terrain. With a tough American heritage, the 4900 is robust and reliable, maximising productivity.



BUILT TOUGH



YOU ASKED, YOU GOT IT

Western Star is all about choice and the 4900 is no exception. Power your prime mover with the engine of your choice. You can opt for a Detroit DD15 or a Cummins X15. This power of choice combined with Western Star's inherent efficiency means you are poised for profit, whatever you decide.

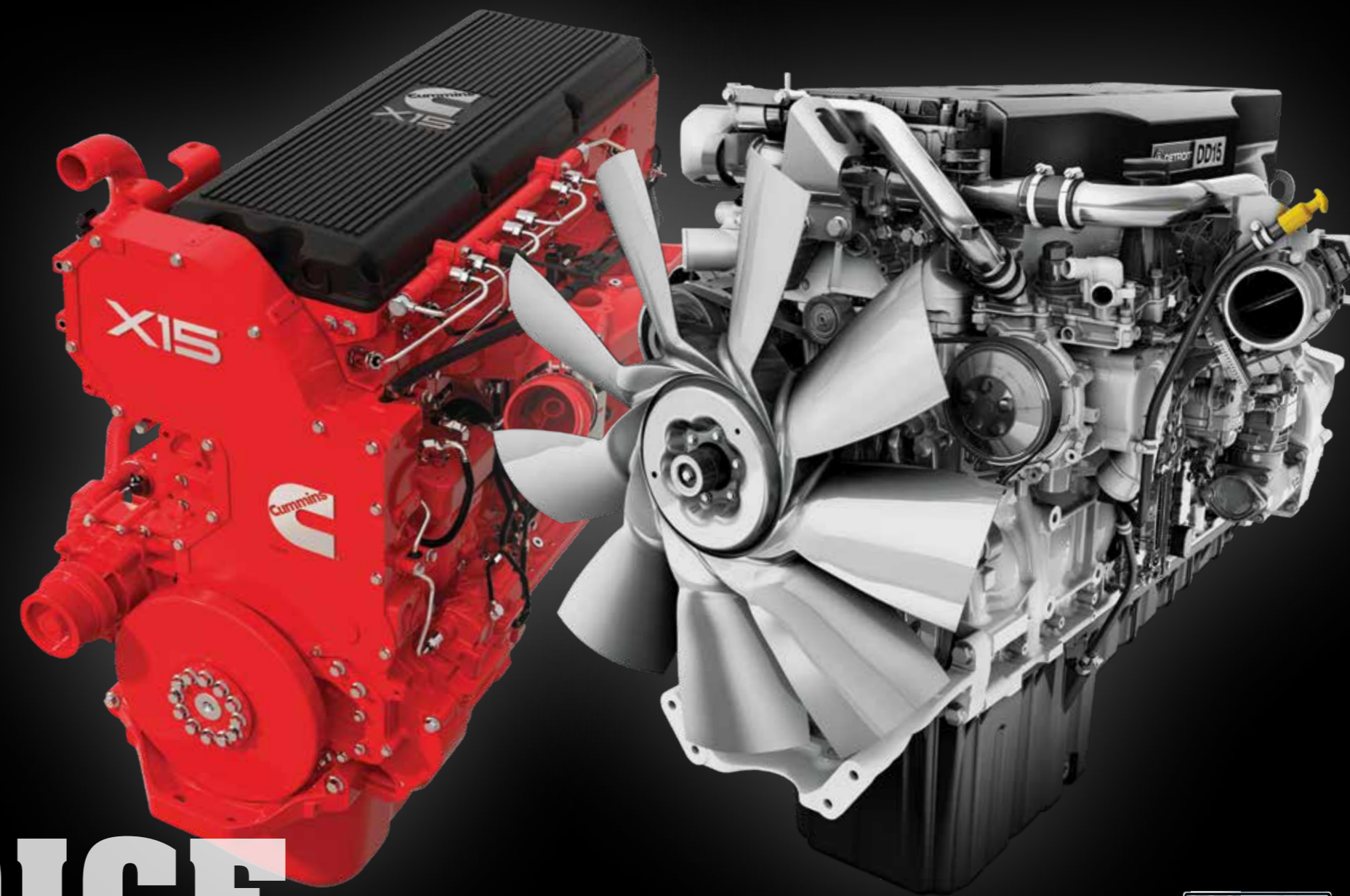

THE POWER OF CHOICE



STATUS COMES FROM EXPERIENCE

The 4900 is famous for good reason. This Star encapsulates the essence of Western Star's heritage in Australia. Handcrafted to meet tough conditions but not rough on resources. Powerful. Versatile. And you get to choose your own adventure with this truck. Whether it's a road train, used for logging, moving livestock, bulk haul, or general freight, your Star is built to meet your exact specs. Now that's legendary.



A LEGEND



SPECIFICATIONS

WESTERN STAR 4900 (6X4)*	
Engine	Detroit DD15 / Cummins X15
Transmission	Eaton Manual & Ultrashift
Front Suspension	Tapered leaf with flat leaf option. Ratings: 7.2 tonne (16,000lbs std. 6.6 tonne (14,600lbs) and 9 tonne (20,000lbs) optional
Rear Suspension	Airliner 40/46k, Tuff Trac, Hendrickson, Neway. Ratings: 40,000lb-52,000lb
Front Axle	Meritor MFS73, FG941 option. Capacity: 6,500-9,100kg
Rear Axle	Meritor, Dana Spicer. Capacity: 40,000lb-52,000lb
GVM	Up to 26,000kg
GCM	160,000kg
Wheelbase	Optional wheelbases available
Cab Options	Detroit: 54" and 68" Stratosphere
	Cummins: Day Cab, 54" Stratosphere (Sleeper)

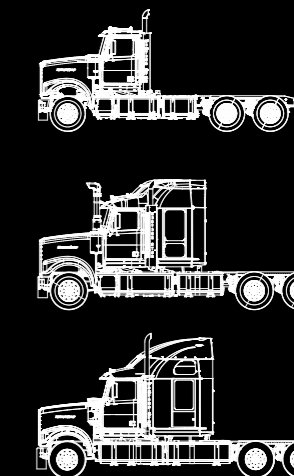
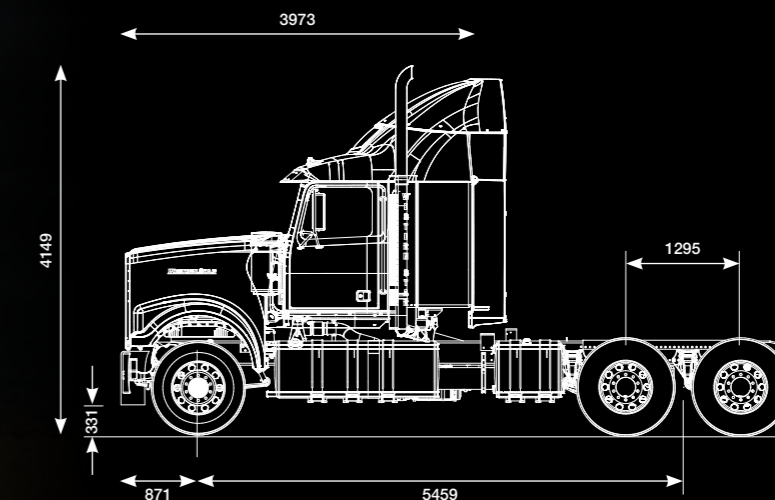

*Specifications subject to change based on state regulations.



SUPPORT

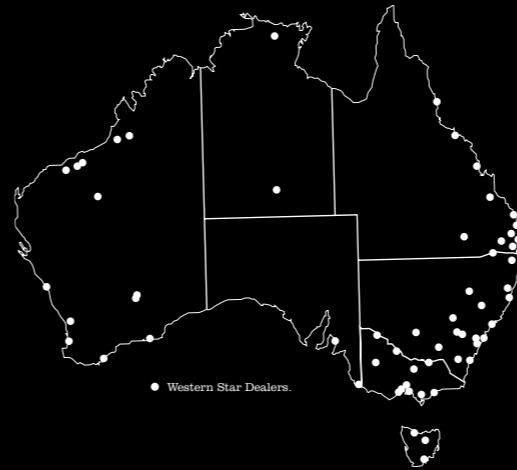

BACKED BY PENSKE

Penske Commercial Vehicles is the exclusive importer and distributor of Western Star Trucks, MAN Truck & Bus, as well as Dennis Eagle Trucks across Australia and New Zealand. Penske Commercial Vehicles is a subsidiary of Penske Automotive Group, a worldwide leader in automotive retail and transportation services, operating automotive and commercial truck dealerships in the United States, Canada and Western Europe, and employing more than 26,000 people globally. With a network of 70 company-owned and independent dealers across Australia and New Zealand, Penske Commercial Vehicles provides full authorised parts, service and warranty functions. No matter where your job takes you, there will be a Western Star dealer nearby ready to help.

W 4900





PENSKE DISTRIBUTION CENTRE

In addition to our extensive network of 70 dealers across Australia and New Zealand, customers are also fully supported by the Penske Distribution Centre (PDC). Located in Wacol, QLD, our state-of-the-art PDC comprises a total floor area of 20,000 sq metres and has an inventory of over 1.3 million parts. Our efficient picking and packing processes ensure we are able to meet high levels of performance and effectiveness, achieving an on-time dispatch of 99.9% and an accuracy rate of 99.87%. From our operations through to the vehicles you drive, we are committed to you.

NETWORK

W 4900





WESTERN STAR TRUCKS®

Penske Commercial Vehicles
Wacol, Queensland 4076
Phone: + 61 7 3271 7777

WESTERNSTAR.COM.AU