



WESTERN STAR TRUCKS®



ENGINEERED TO BE EFFORTLESS

Navigating Australian roads with heavy loads has never been smoother than in a Western Star 5800. This Star model moves with a style that appears effortless. But we've engineered it that way. Enhanced by a sloped, high visibility bonnet and set-back front axle, this heavy duty truck can handle a wide variety of applications with peerless manoeuvrability. Put muscle into movement with your choice of engine, driveline and suspension. Your Star, your way.



LET'S GET SERIOUS

W 5800





A MODEL THAT'S UPFRONT

The 5800 set-back front axle allows for outstanding manoeuvrability and superior visibility. Combining comfort and technology, this Star will suit all your needs. The full-width, walk-through cabin provides all the comfort of home, while out on the road. With this Star, you'll meet and exceed any challenge with ease!



VERSATILE STAR

The multifaceted 5800 will easily fit into your fleet whatever the application. Ideal for b-double, linehaul, tipper and dog, logging, or single trailer use, the 5800 is your all-purpose Star.

TOUGH & TRUSTED

W 5800



RELIABILITY IS THE DIFFERENCE

Western Star is all about choice and the 5800 is no exception. Opt for either a Detroit DD13 or DD15 engine and put muscle into your movement with engine ratings up to 560hp. Backed by an expansive national network of support and an industry-leading warranty package, you can rest assured. Whatever you choose, with Detroit you'll have reliability you can count on, while keeping your whole-of-life costs low, and your uptime high.

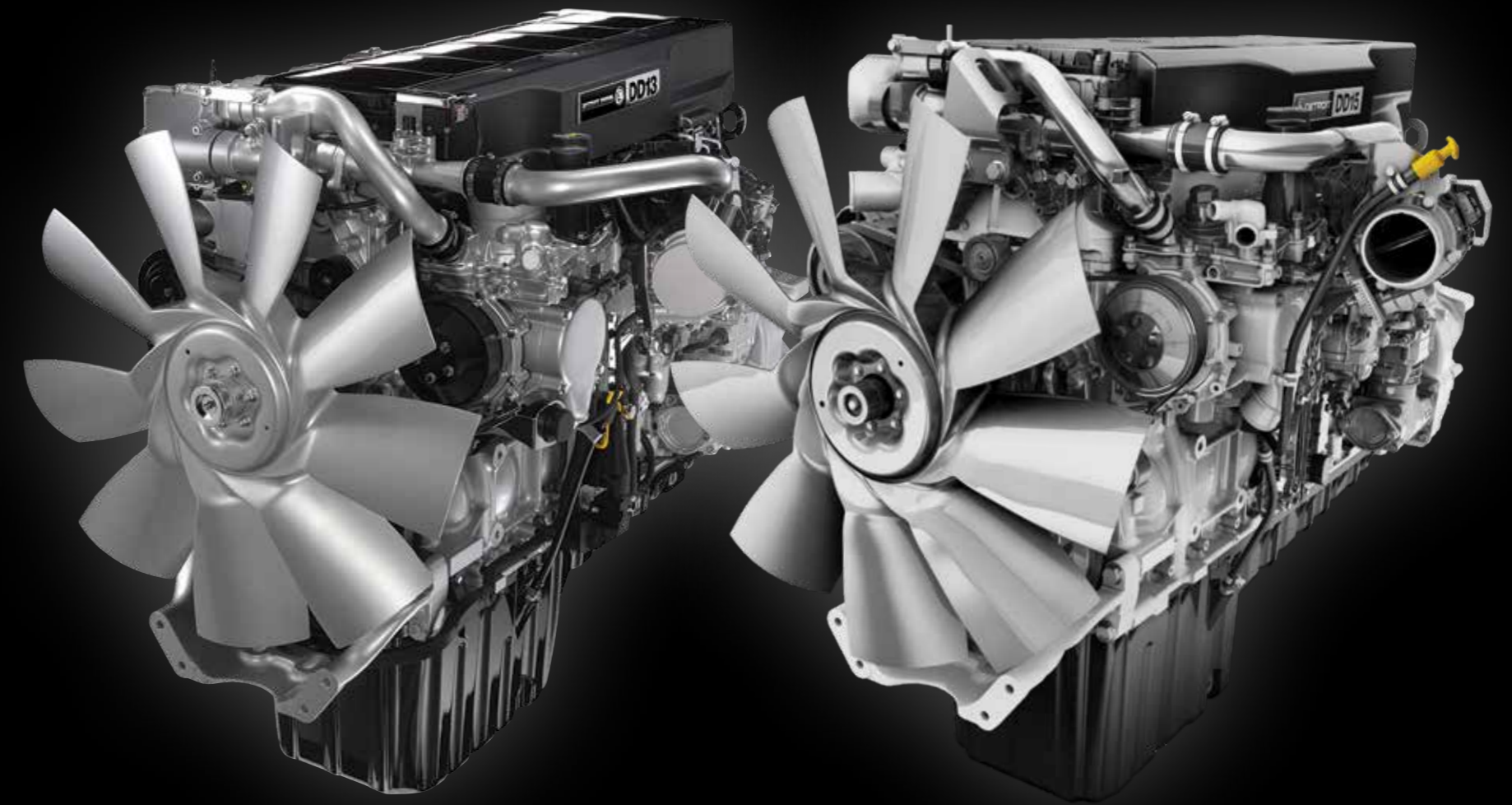

DETROIT POWER

W 5800



YOUR CAB YOUR CASTLE

You won't find any aluminium or rivets on this Star. It's a Star of steel. Built for strength. The galvanised steel cab is designed to maximise your protection. Precision-welded for strength, the cab is dipped in a 17-stage e-coat process for long-lasting corrosion resistance. Handcrafted and built with the highest quality US-manufactured componentry, this is one tough Star.

STAR OF STEEL



SPECIFICATIONS

WESTERN STAR 5800 (6X4 - DAY CAB)*	
Engine	Detroit DD15 / DD13
Transmission	Eaton Manual & Ultrashift & Allison 4500
Front Suspension	Tapered leaf & flat leaf. Ratings: 7,250kg
Rear Suspension	Airliner 40/46k, Tuff Trac. Ratings: 40,000lb-46,000lb
Front Axle	Meritor MFS73 std, FG941 option. Capacity: 6,622-7,258kg
Rear Axle	Meritor, Dana Spicer. Capacity: 40,000lb-46,000lb
GVM	26,000kg
GCM	Up to 106,000kg
Wheelbase	Optional wheelbases available
Cab Options	Day Cab

WESTERN STAR 5800 (6X4 - SLEEPER CAB)*	
Engine	Detroit DD15 / DD13
Transmission	Eaton Manual & Ultrashift & Allison 4500
Front Suspension	Tapered leaf & flat leaf. Ratings: 7,250kg
Rear Suspension	Airliner 40/46k, Tuff Trac. Ratings: 40,000lb-46,000lb
Front Axle	Meritor MFS73 std, FG941 option. Capacity: 6,622-7,258kg
Rear Axle	Meritor, Dana Spicer. Capacity: 40,000lb-46,000lb
GVM	26,000kg
GCM	Up to 106,000kg
Wheelbase	Optional wheelbases available
Cab Options	34" low roof Starlite, 34", 40" and 54" Stratosphere

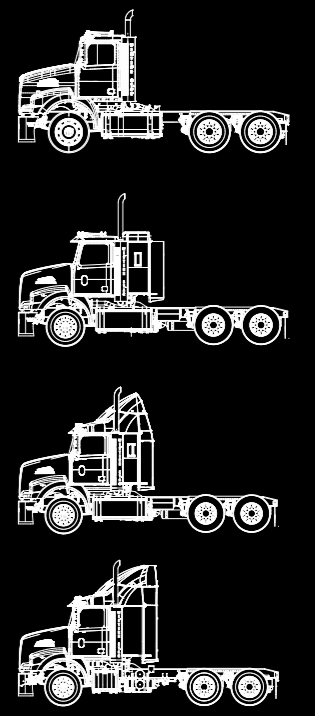
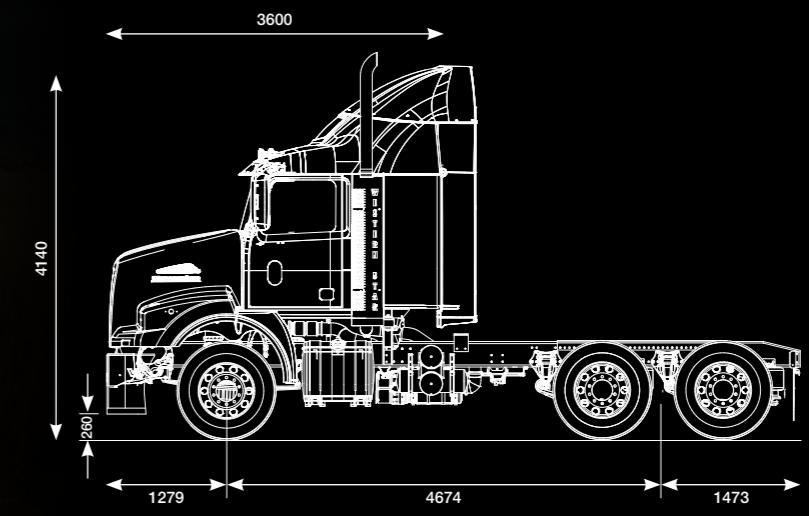
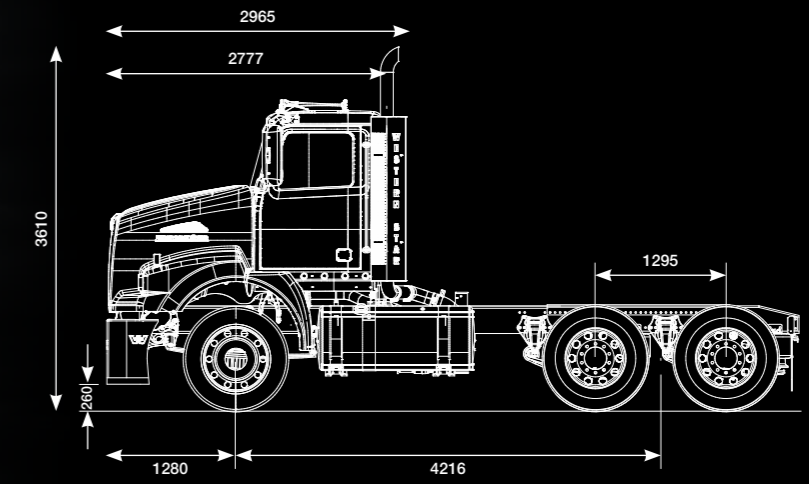

*Specifications subject to change based on state regulations.



SUPPORT

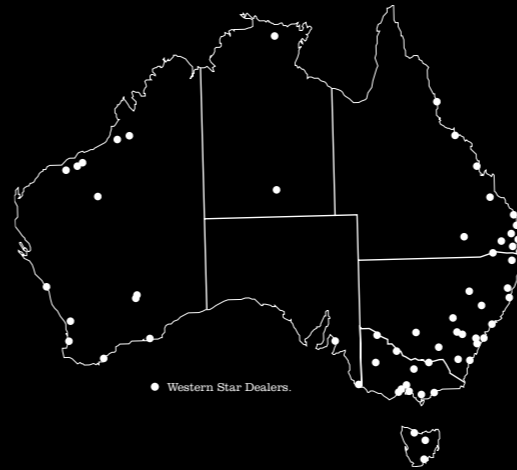

• Western Star Dealers.

BACKED BY PENSKE

Penske Commercial Vehicles is the exclusive importer and distributor of Western Star Trucks, MAN Truck & Bus, as well as Dennis Eagle Trucks across Australia and New Zealand. Penske Commercial Vehicles is a subsidiary of Penske Automotive Group, a worldwide leader in automotive retail and transportation services, operating automotive and commercial truck dealerships in the United States, Canada and Western Europe, and employing more than 26,000 people globally. With a network of 70 company-owned and independent dealers across Australia and New Zealand, Penske Commercial Vehicles provides full authorised parts, service and warranty functions. No matter where your job takes you, there will be a Western Star dealer nearby ready to help.





PENSKE DISTRIBUTION CENTRE

In addition to our extensive network of 70 dealers across Australia and New Zealand, customers are also fully supported by the Penske Distribution Centre (PDC). Located in Wacol, QLD, our state-of-the-art PDC comprises a total floor area of 20,000 sq metres and has an inventory of over 1.3 million parts. Our efficient picking and packing processes ensure we are able to meet high levels of performance and effectiveness, achieving an on-time dispatch of 99.9% and an accuracy rate of 99.87%. From our operations through to the vehicles you drive, we are committed to you.

NETWORK

W 5800





WESTERN STAR TRUCKS®

Penske Commercial Vehicles

Wacol, Queensland 4076

Phone: + 61 7 3271 7777

WESTERNSTAR.COM.AU