

SWIFT



#SWIFTLIFE





LIVE *LIFE* IN THE
SWIFT
LANE

A car needs to stir the emotions from the way it looks to the way it drives.

An overwhelming sense of presence and confidence.

Welcome to a daily desire to get behind the wheel and to an exciting car experience that knows no end.

Live your life in the Swift lane!

Delivering heart-throbbing driving feedback and uncompromising fuel efficiency through advanced technologies.



Two engines with different characteristics

The 1.0 BOOSTERJET (GLX) direct-injection turbo engine creates torque on par with those of a naturally aspirated 1.8-litre engine. Its direct-injection system contributes to delivering low fuel consumption and the lowering of temperatures within the engine's cylinders. The turbocharger, which forces compressed air into the cylinders, produces high engine torque from a low revolution range, making it suitable for a wide range of driving environments.

Meanwhile, the 1.2 DUALJET engine features dual injectors for each cylinder, which results in greatly increased efficiency. It is a responsive engine that strikes an ideal balance between optimal power and good fuel performance.



The Swift has a completely new chasis, body structure and powertrain that ensures the driver is at one with the car. The range of advanced technologies, incorporated and/or available in the Swift; results in an increased level of excitement, confidence and control.

HEARTECT

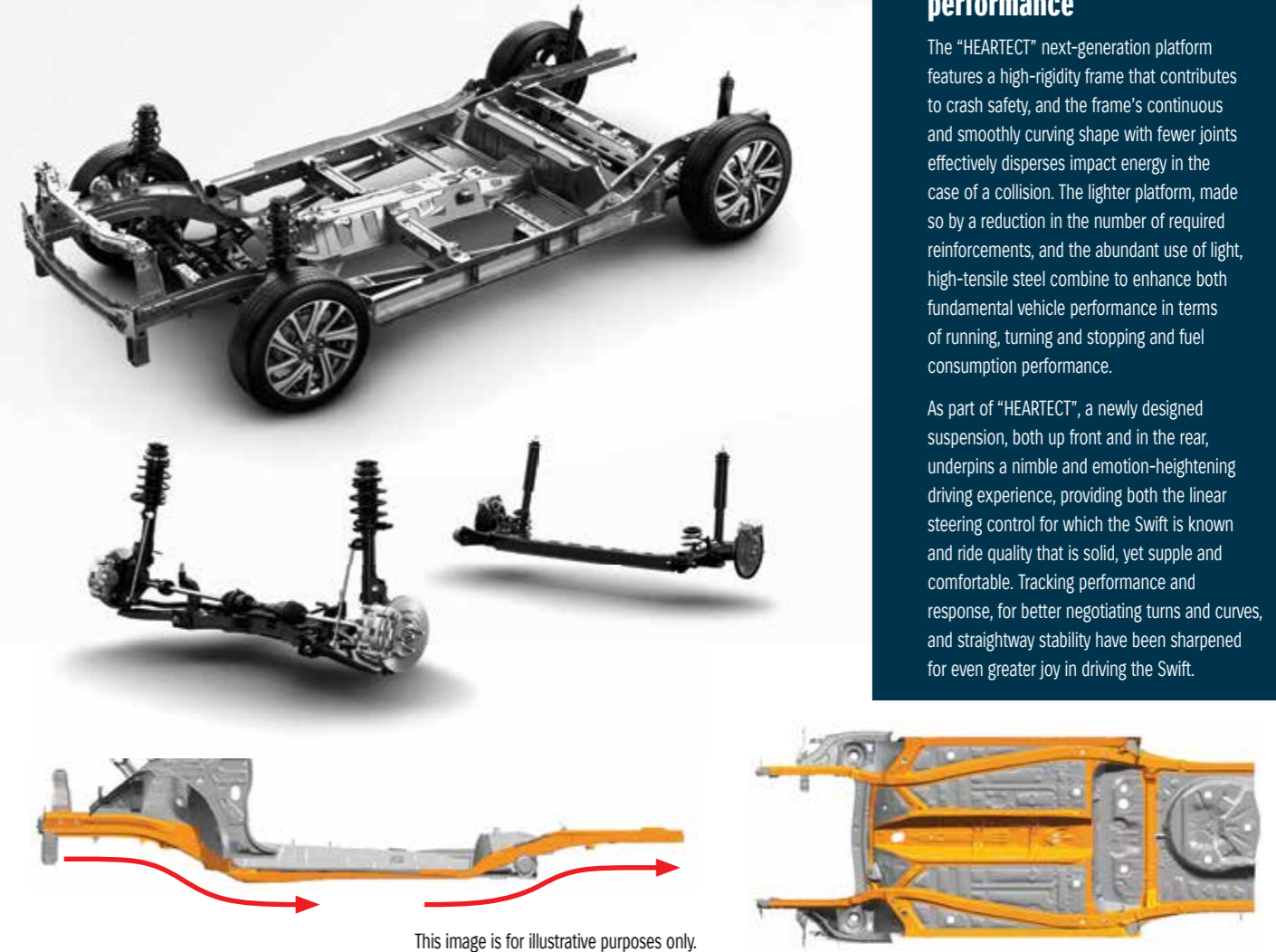

Lightness and strength for enhanced fundamental performance

The "HEARTECT" next-generation platform features a high-rigidity frame that contributes to crash safety, and the frame's continuous and smoothly curving shape with fewer joints effectively disperses impact energy in the case of a collision. The lighter platform, made so by a reduction in the number of required reinforcements, and the abundant use of light, high-tensile steel combine to enhance both fundamental vehicle performance in terms of running, turning and stopping and fuel consumption performance.

As part of "HEARTECT", a newly designed suspension, both up front and in the rear, underpins a nimble and emotion-heightening driving experience, providing both the linear steering control for which the Swift is known and ride quality that is solid, yet supple and comfortable. Tracking performance and response, for better negotiating turns and curves, and straightway stability have been sharpened for even greater joy in driving the Swift.

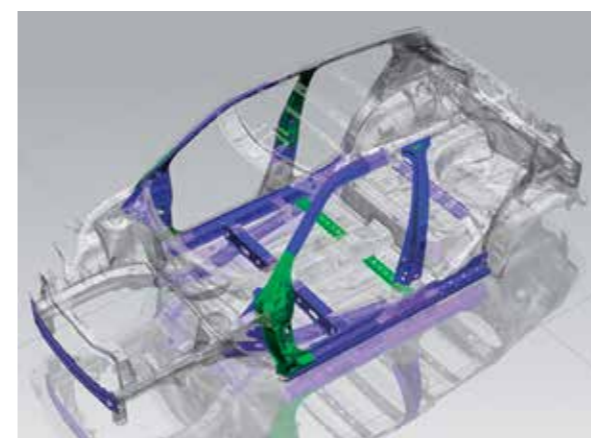

Light and highly rigid body for nimble and agile driving and good fuel economy

Extensive use of high-tensile steel and ultra-high-tensile steel, such as in the upper body and underbody, achieves both lightness and high rigidity for enhanced driving performance and excellent fuel performance.



Minimum turning radius of 4.8m for easier manoeuvrability

Use of the new platform allowed for a wider turning angle, resulting in a turning radius of only 4.8m. This enables small turns for easier manoeuvrability on narrow streets and in tight parking spaces, for a more-pleasant overall driving experience.

The cabin is designed with the driver in mind. After getting into the driver's seat, you are instantly at one with the car.



Multi-information display

A stylish gauge cluster stands out with two separate colour arrangements: a red dial on a black-and-white tachometer face and a dark silver speedometer. Boost/oil temp gauges on the centre 4.2-inch colour display* with digital speedo to fully enhance both the look and functionality.

*Available on GLX model.



Smartphone Linkage Display Audio

(Standard on GL Navi, GL Navi + & GLX models)

A 7-inch touchscreen display enables intuitive operation of multimedia features including audio, hands-free phone, navigation system and smartphone integration. Features can be selected from the four main operating modes—Listen, Call, Drive and Connect. The Smartphone Linkage Display Audio works with Apple CarPlay®, Android Auto™ and MirrorLink™. By connecting your compatible iPhone via USB, Apple CarPlay® allows you to make phone calls, access your music, send and receive messages, and get directions all by voice command or a tap on the audio display. Android Auto™ puts Google Maps™, Google Search™ and other Google services at the driver's fingertips in a non-distracting way. MirrorLink™ lets various applications on your smartphone appear on the vehicle's touchscreen display, allowing you to access your smartphone's features.



Apple CarPlay® is available in the countries listed at the following link: <http://www.apple.com/ios/feature-availability/#applecarplay-applecarplay>
 *For more details including iPhone® models compatible with Apple CarPlay® see: <http://www.apple.com/ios/carplay/>
 *Apple®, Apple CarPlay® and iPhone® are trademarks of Apple Inc., registered in the U.S. and other countries.
 *Android Auto™ is available in the countries listed at the following link: <https://www.android.com/auto/hit-the-road>
 *Most phones with Android™ 5.0+ works with Android Auto™: <https://support.google.com/androidauto/#6140477>
 *Android™, Android Auto™, Google™, Google Play™ and other marks are trademarks of Google Inc.
 *MirrorLink™ is compatible with the smartphones listed at the following link: <https://cert.mirrorlink.com/ProductListing/>
 *MirrorLink™ is a registered trademark of the Car Connectivity Consortium LLC.



5-speed manual transmission



CVT with auxiliary transmission



6-speed automatic transmission



Bluetooth®-compatible audio system for wireless connectivity

(Standard on GL model)

The audio system, equipped with an AM/FM radio and CD player, uses a high-contrast LCD panel for easy recognition. Connectivity comes in the form of either a wired USB connection or through Bluetooth®, with the later enabling hands-free mobile phone use and wireless enjoyment of music stored on MP3/WMA-compatible portable audio devices.

*Bluetooth is a registered trademark of Bluetooth SIG, Inc.



Cruise control for easier driving

A cruise control system keeps the car moving at the speed set by the driver, reducing driver burden and making long-distance motor way driving easier.

The Limit function allows a pre-set maximum speed to be selected and prevents gentle pressure of the accelerator exceeding the set limit.

Space that rouses the playfulness within, beckoning you to get out and do more.



Compact on the outside for easy manoeuvring and roomy on the inside for occupants and belongings. An evolution in vehicle packaging allows the Swift to meet the needs of drivers who want both. With fun to drive always being a must, a little extra allowance in the cabin and luggage space can go a long way when you live your life in the Swift lane.

Cabin and luggage space that expands the way you have fun

The Swift's plentiful luggage space allows you to take more, and the split, fold-down rear seatbacks help you fit what you need. Ample head clearance is provided by low seating positions, and numerous easy-to-use storage spaces are a short reach away.



Air conditioner with easy-to-read display and easy-to-use controls

The GL models are equipped with a manual air conditioner with simple controls for operational convenience. The air conditioner control panel on the GLX allows intuitive operation. Easy recognition has also been made possible through the use of a high-contrast LCD.

Peace of mind created by advanced technologies further accelerates the fun of driving.



Advanced forward detection system

(using the combination of a monocular camera, laser sensor and millimetre-wave radar)

(Standard on GL Navi + & GLX models)

In a Suzuki first-time application, a monocular camera and laser sensor are attached to the windshield. When the vehicle is equipped with both millimetre-wave radar and the combination of a monocular camera and laser sensor, the monocular camera and laser sensor govern the collision mitigation brakes and the millimetre-wave radar is used for the Adaptive Cruise Control function.

The combination of a monocular camera, which excels in mid-to-long distance performance & can also detect pedestrians, and a laser sensor, which excels at short-distance & nighttime detection, expands the safety functions of the vehicle. These include the application of a collision mitigating braking function, a lane departure warning function, a high beam assist function and a weaving alert function.

Blind Spot Monitor (BMS)

(Standard on GL Navi + & GLX models)

At 15km/h or faster, two rear mounted side radar sensors detect vehicles located in or approaching the rear blind spot to assist the driver. A warning LED icon illuminated in the relevant door mirrors alerts the driver, accompanied by a warning sound if the driver activates the turn signals to change lanes.

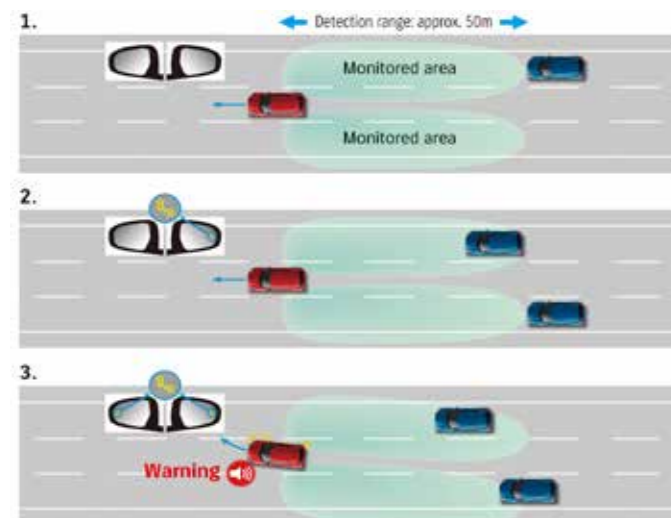

Rear Cross Traffic Alert

(Standard on GL Navi + & GLX models)

At speeds of up to 8 km/h whilst in reverse, the vehicle uses two rear mounted side radar sensors to assist the driver by alerting them of approaching vehicles on either side of the vehicle when reversing out of car parking spaces. If a vehicle is detected, the driver is given both a visual alert on the multi information display and a warning sound alert. This assists the driver to manoeuvre more safely out of parking spaces where vision is obscured on either or both sides of the vehicle.



Rear Parking Sensor

(Standard on GL Navi + & GLX models)

Ultrasonic sensors in the bumper detect obstacles while the driver is reversing the car and warning sounds inform the driver of the distance to the obstacles.



Dual Sensor Brake Support (DSBS)

(Standard on GL Navi + and GLX models)

When moving, the Swift uses two sensors—a monocular camera and a laser sensor—to determine if there is a risk of collision with a forward vehicle or pedestrian. Upon detecting a potential collision, the car acts in any of the following three ways, depending on the situation.

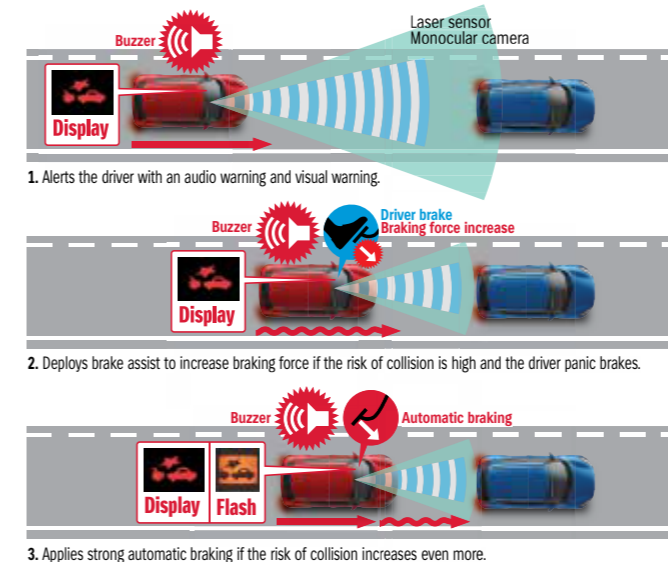

Lane departure warning

(Standard on GL Navi + & GLX models)

At 60km/h or faster, the lane departure warning function is designed to predict the path of the vehicle and issue visual (display and indicator) and tactile (vibrating steering wheel) warnings to the driver.



Weaving alert

(Standard on GL Navi + & GLX models)

At 60km/h or faster, the weaving alert is designed to calculate the driving pattern and issue audio and visual warnings if the vehicle is "wandering" due to driver drowsiness etc.

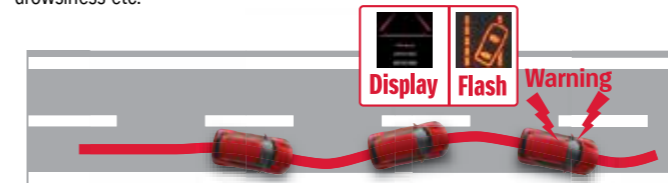

High beam assist

(Standard on GLX model)

At 40km/h or faster, high beam assist is designed to automatically switch the headlights between "High" and "Low", depending on the presence of other vehicles and the lighting environment.

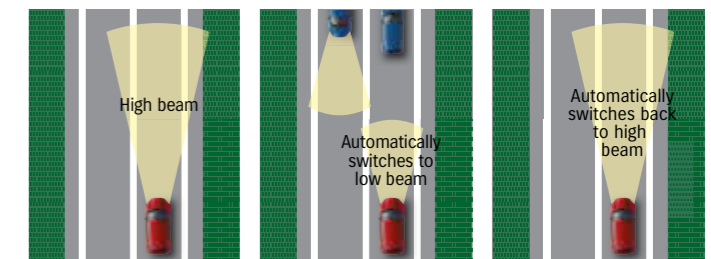

When high beam use deemed appropriate High beam

After detecting lights of oncoming or preceding vehicle Automatically switches to low beam

When oncoming or preceding vehicle no longer present Automatically switches back to high beam

Adaptive cruise control

(Standard on GL Navi + & GLX models)

When there is a vehicle in front, the adaptive cruise control system uses millimetre-wave radar designed to gauge the distance to it and automatically maintains vehicle-to-vehicle distance in line with the setting selected out of three possible settings*. When there is no vehicle in front, the system maintains the speed (from 40km/h to 160km/h) set by the driver.

*Vehicle-to-vehicle distance varies depending on vehicle speed.

1. Constant speed control



2. Deceleration control



3. Acceleration control



ABS with EBD for supporting driver braking

ABS is a system that detects the rotation of each wheel through the use of sensors attached to the four wheels and automatically and optimally controls braking force. It prevents the tires from locking, which can easily occur in sudden braking or on slippery surfaces, and heightens the driver's ability to avoid obstacles through steering. Furthermore, EBD (electronic braking-force distribution) optimally distributes front and rear braking force to help stably stop the vehicle.

ABS with EBD

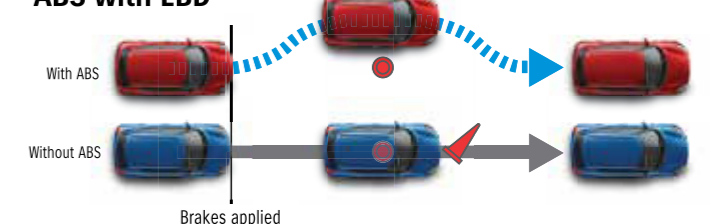

The above listed safety functions are designed to assist the driver only. It does not eliminate the need to drive safely or in accordance with the driving conditions.



SWIFT
Sport
Turbo



#SWIFTLIFE



Way of Life *Made for thrills!*



Ultimate Sportiness

The interior is unmistakably sporty and race design inspired with striking red to black panels. An exclusive meter cluster stands out with two separate colour arrangements: a red dial on a black-and-white tachometer face and a dark silver speedometer. Boost/oil temp gauges on the centre 4.2-inch colour display with digital speedo enhance the spirited look.

Sculpted front bucket seats complete with embossed "Sport" logo and red stitching provide comfort and support whilst optimising your feel for the road.

Connect to the world with your smartphone, accessing its apps via the 7-inch touchscreen display.



Apple CarPlay® is available in the countries listed at the following link: <http://www.apple.com/ios/feature-availability/#applecarplay-applecarplay>
For more details including iPhone models compatible with Apple CarPlay® see: <http://www.apple.com/ios/carplay/>
Apple®, Apple CarPlay® and iPhone® are trademarks of Apple Inc., registered in the U.S. and other countries.
Android Auto™ is available in the countries listed at the following link: <https://www.android.com/auto/#hit-the-road>
Most phones with Android™ 5.0+ works with Android Auto™: <https://support.google.com/androidauto/#6140477>
Android™ and Android Auto™ are trademarks of Google Inc.
MirrorLink™ is compatible with the smartphones listed at the following link: <https://cert.mirrorlink.com/ProductListing/>
MirrorLink™ is a registered trademark of the Car Connectivity Consortium LLC.

Driving Pleasure

Chassis and suspension performance directly impacts the pleasure of a sporty drive. So, the body of the Swift Sport Turbo is now lighter and more rigid for drivers to maintain steering control at any speed, in any manoeuvre. The suspension system has been dramatically enhanced to provide clear feedback regarding road and traction conditions. Furthermore, the braking system is newly refined and reinforced to cope with the higher power and speed.



Handling and Traction

The Swift Sport Turbo adopts the new-generation platform HEARTECT to strengthen underbody rigidity, enhance collision safety and heighten driving performance. The vehicle's light 970kg weight advances driving stability dramatically. Renowned Monroe® front struts and rear shock absorbers are adopted for the suspension system. The new Swift Sport reaches yet another frontier with outstanding balance between exhilarating manoeuvrability and road holding performance.

*Monroe® is a registered trademark of Tenneco Automotive.

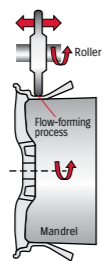

17-inch Alloy Wheels

The exclusive thin-spoke alloy wheels are crafted using a flow forming technique that enables thinner yet stronger rims for a reduction in unsprung weight that enhances vehicle performance.

Braking Performance

Braking performance can be even more important at times than driving performance, so the Swift Sport Turbo employs 16-inch ventilated front disc brakes and 15-inch solid rear disc brakes for superior braking power and feel.



16-inch ventilated front disc brakes 15-inch solid rear disc brakes

Exciting Performance

Distinctive hot hatch performance is embodied by highly responsive acceleration, made possible by the newly installed turbo engine's powerful 230 N·m torque. Such performance is perfectly complemented by a smooth-shifting six-speed transmission. The powertrain's great refinement opens the way to the next stage of sporty driving.



1.4 BOOSTERJET Engine

The new, compact 1.4 BOOSTERJET direct injection turbo engine harnesses the power of torque in the driving of the latest Swift Sport. The intercooled turbocharger forces pressurised air into cylinders and enables the engine to maximise torque in the low engine rev range, even at 2500rpm, dramatically quickened response and lowered fuel consumption. The direct injection system further enhances fuel efficiency by optimising control of the amount, timing and pressure of injected fuel allowing faster acceleration.

Superior Transmissions

Both the manual and automatic smooth-shifting six-speed transmissions maximise the performance of the compact turbo engine.



Safety and Utility

Dual Sensor Brake Support (DSBS)

When moving, the new Swift Sport uses two sensors – a monocular camera and a laser sensor – to determine if there is a risk of collision with a forward vehicle or pedestrian. Upon detecting a potential collision, the car acts in any of the following three ways, depending on the situation.

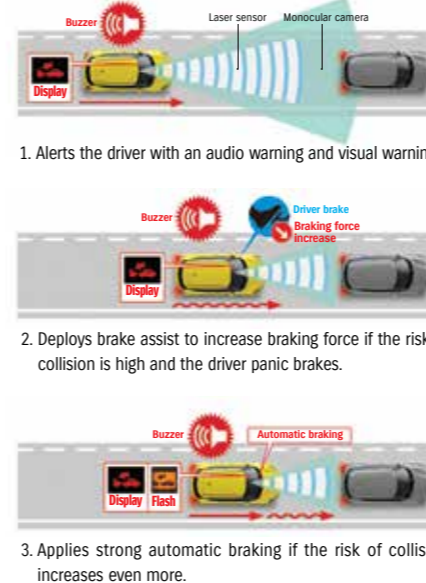

Rear parking sensor

Ultrasonic sensors in the bumper detect obstacles while the driver is reversing the car and warning sounds inform the driver of the distance to the obstacles.



Blind spot monitor (BSM)

At 15km/h or faster, two rear mounted side radar sensors detect vehicles located in or approaching the rear blind spot to assist the driver. A warning LED icon illuminated in the relevant door mirrors alerts the driver, accompanied by a warning sound if the driver activates the turn signals to change lanes.

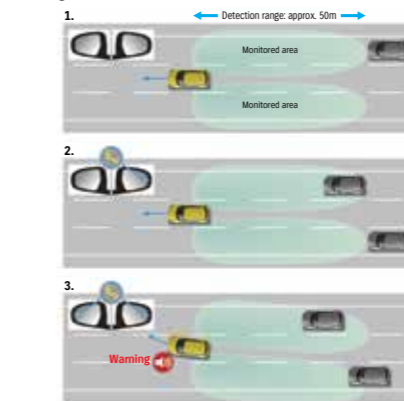

Lane Departure Warning

At 60km/h or faster, the lane departure warning function is designed to predict the path of the vehicle and issue visual (display and indicator) and tactile (vibrating steering wheel) warnings to the driver (standard on vehicles with DSBS).



At 60km/h or faster, the weaving alert is designed to calculate the driving pattern and issue audio and visual warnings if the vehicle is "wandering" due to driver drowsiness, etc. (standard on vehicles with DSBS).

High Beam Assist

At 40km/h or faster, high beam assist is designed to automatically switch the headlights between "High" and "Low", depending on the presence of other vehicles and the lighting environment.

Rear cross traffic alert

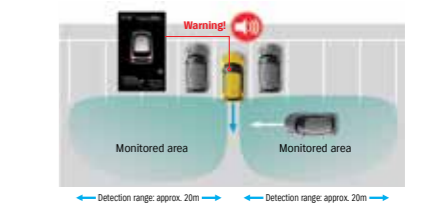

At speeds of up to 8 km/h whilst in reverse, the vehicle uses two rear mounted side radar sensors to assist the driver by alerting them of approaching vehicles on either side of the vehicle when reversing out of car parking spaces. If a vehicle is detected, the driver is given both a visual alert on the multi information display and a warning sound alert. This assists the driver to manoeuvre more safely out of parking spaces where vision is obscured on either or both sides of the vehicle.

Adaptive Cruise Control (ACC)

When there is a vehicle in front, the adaptive cruise control system uses millimetre-wave radar designed to gauge the distance to it and automatically maintains vehicle-to-vehicle distance in line with the setting selected out of three possible settings.* When there is no vehicle in front, the system maintains the speed (from 40km/h to 160km/h) set by the driver.

*The vehicle-to-vehicle distance varies depending on vehicle speed.

ABS with EBD for supporting driver braking

ABS is a system that detects the rotation of each wheel through the use of sensors attached to the four wheels and automatically and optimally controls braking force. It prevents the tires from locking, which can easily occur in sudden braking or on slippery surfaces, and heightens the driver's ability to avoid obstacles through steering. Furthermore, EBD (electronic braking-force distribution) optimally distributes front and rear braking force to help stably stop the vehicle.

The above listed safety functions are designed to assist the driver only. It does not eliminate the need to drive safely or in accordance with the driving conditions.



Way of Life!

Suzuki's "Way of Life!" is the heart of our brand - every Suzuki vehicle, motorcycle and outboard motor is built to create excitement so customers can enjoy everyday life.



www.suzukiqld.com.au

All care is taken to ensure the accuracy of this brochure at the time of publication approval. Specifications, features, prices and model availability may vary from State to State and may change without notice. Always consult your authorised Suzuki Dealer or refer to www.suzukiqld.com.au for the latest details on all models. SUZUKI will not be held liable for any loss as a result of reliance on the content of this brochure, whether in negligence or otherwise. Vehicles are shown for illustrative purposes only and may not depict exact Australian specifications. Published May 2021.