



WESTERN STAR TRUCKS®





## TOUGH, RELIABLE, AND TALENTED

---

The 4700 was made to order – you asked, we delivered. Literally. Input from the Australian trucking community led to the birth of this model. Designed and built to meet a range of vocational applications, the low tare weight advantage combined with superior manoeuvrability, makes this truck the perfect fit for agitator and tip truck configurations. But its talents don't end there. The easy ingress into and egress out of the truck, along with the sloped bonnet, and set-back front axle deliver on safety and comfort. Tough, reliable and talented, the 4700 brings you true Star quality.

# LET'S GET SERIOUS



W 4700







# TURN HEADS & TIGHT CORNERS



## MASTER OF MANOEUVRE

This Star is all about drivability. It's strong but moves easily, even in tight spaces. The sloped bonnet and set-back front axle give you abilities like no other truck on the road. We've also designed it so it's easy to service.

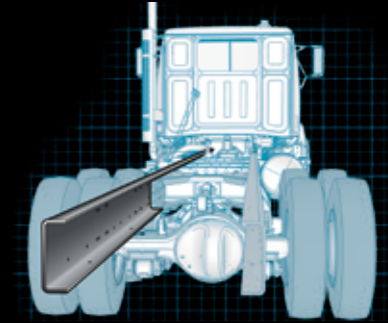

## LIGHT WEIGHT & STRONG

The 4700 proves that a Star can be both strong and light. The single-channel frame rails available on this model give you strong performance, without the added weight. This Star is ready for your specific application - giving you optimal strength.

W 4700



## POWER AND PERFORMANCE

---

This Star not only offers strength, it gives you a simple yet cost-effective means of meeting today's emission regulations. With Cummins ISL engine power, you benefit from reduced maintenance and better fuel economy and while still getting the engine performance and reliability you need on the road.

# CUMMINS POWER

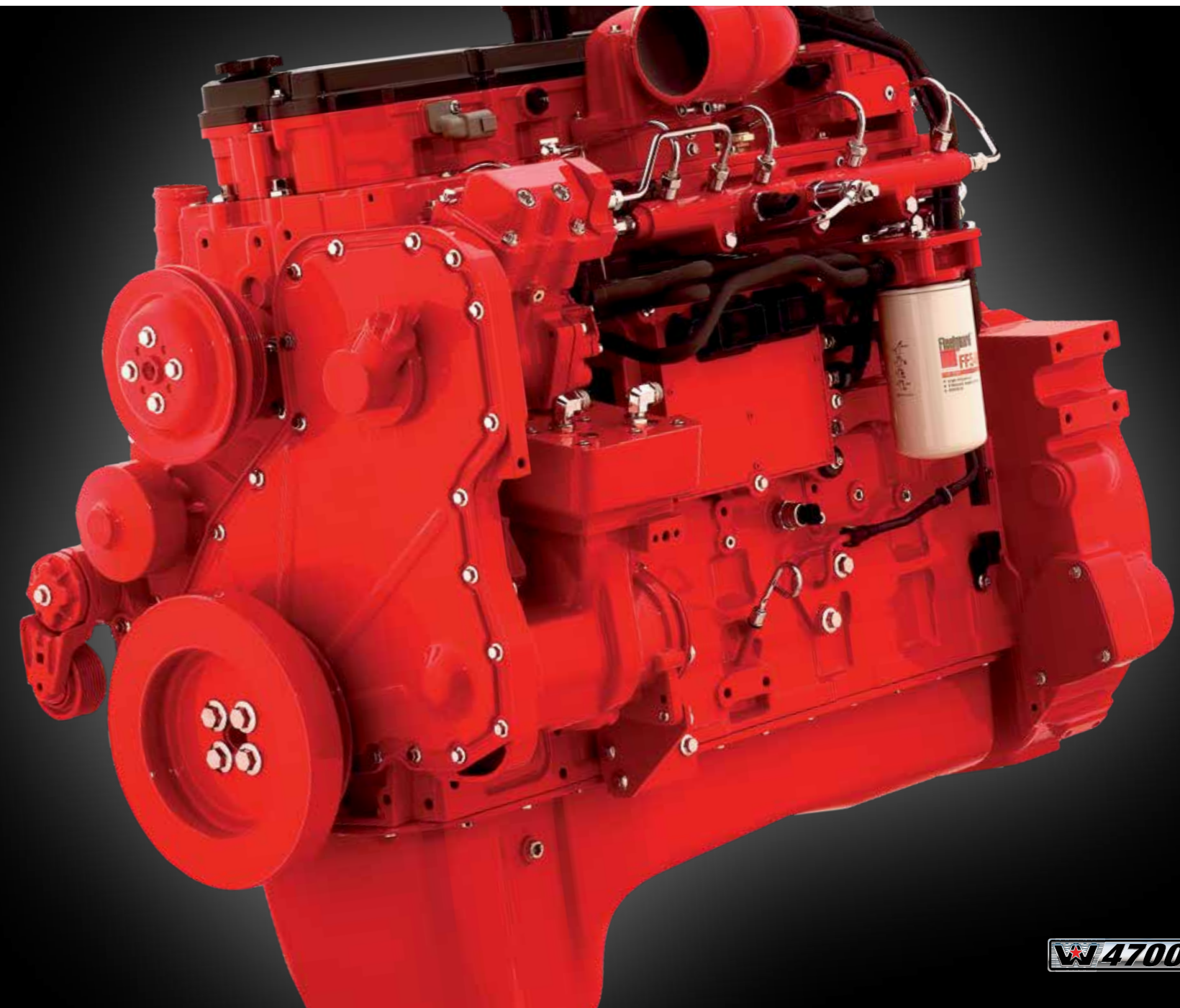

**W4700**





## YOUR CAB, YOUR CASTLE

You won't find any aluminium or rivets on this Star. It's a Star of steel. Built for strength. The galvanised steel cab is designed to maximise your protection. Precision-welded for strength the cab is dipped in a 17-stage e-coat process for long-lasting corrosion resistance. This is one tough Star.

# STAR OF STEEL





# SPECIFICATIONS

| WESTERN STAR 4700 (6X4)* |   |
|--------------------------|---|
| Engine                   | Cummins ISL Euro 5 - 280 - 400 hp                             |
| Transmission             | Eaton Manual, Ultrashift and Allison 3000, 3500 & 4000 series |
| Front Suspension         | Tapered leaf, Ratings: 6,600kg std                            |
| Rear Suspension          | Airliner and Tuff Trac. Ratings: 40,000lb-46,000lb            |
| Front Axle               | Meritor FG-941 or Daimler DA-F-16.0-5                         |
| Rear Axle                | Dana DDH or Meritor MX-40-14XGP or RT-46-160GP                |
| GVM                      | Up to 24,500kg  |
| GCM                      | Up to 42,000kg  |
| Wheelbase                | Optional wheelbases available                                 |
| Cab Options              | Day Cab Only  |

| WESTERN STAR 4700 (8X4)* |  |
|--------------------------|--|
| Engine                   | Cummins ISL Euro 5 - 280 - 400 hp                  |
| Transmission             | Eaton Manual, Ultrashift and Allison 3000 and 4000 |
| Front Suspension         | Tapered leaf, Ratings: 13,245kg std                |
| Rear Suspension          | Airliner and Tuff Trac. Ratings: 40,000lb-46,000lb |
| Front Axle               | Meritor MFS-14-143A                                |
| Rear Axle                | Dana DDH or Meritor MX-40-14XGP or RT-46-160GP     |
| GVM                      | Up to 28,500kg                                     |
| GCM                      | Up to 42,000kg                                     |
| Wheelbase                | Optional wheelbases available                      |
| Cab Options              | Day Cab Only                                       |

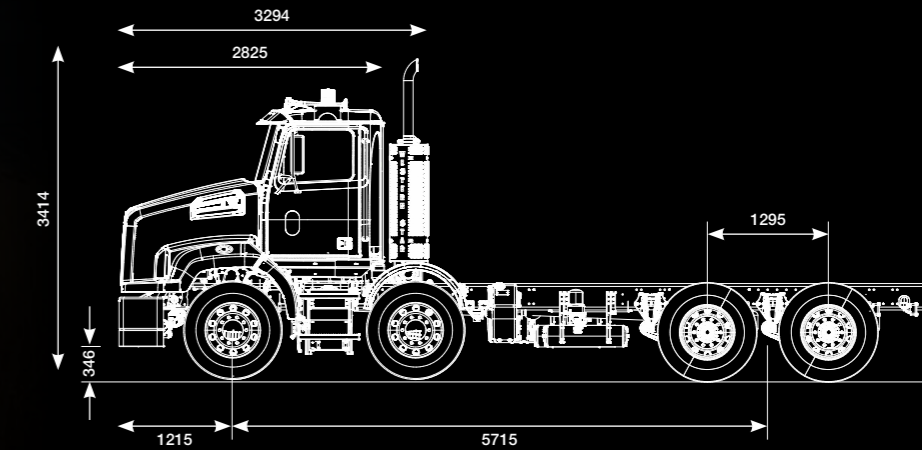
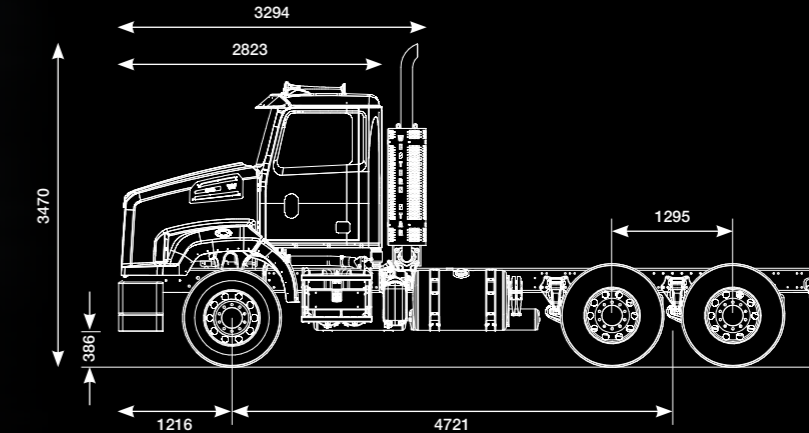

\*Specifications subject to change based on state regulations.





# SUPPORT

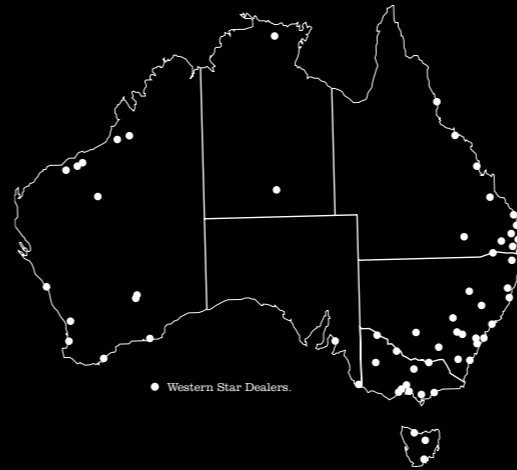

• Western Star Dealers.

## BACKED BY PENSKE

Penske Commercial Vehicles is the exclusive importer and distributor of Western Star Trucks, MAN Truck & Bus, as well as Dennis Eagle Trucks across Australia and New Zealand. Penske Commercial Vehicles is a subsidiary of Penske Automotive Group, a worldwide leader in automotive retail and transportation services, operating automotive and commercial truck dealerships in the United States, Canada and Western Europe, and employing more than 26,000 people globally. With a network of 70 company-owned and independent dealers across Australia and New Zealand, Penske Commercial Vehicles provides full authorised parts, service and warranty functions. No matter where your job takes you, there will be a Western Star dealer nearby ready to help.

WJ 4700







## PENSKE DISTRIBUTION CENTRE

In addition to our extensive network of 70 dealers across Australia and New Zealand, customers are also fully supported by the Penske Distribution Centre (PDC). Located in Wacol, QLD, our state-of-the-art PDC comprises a total floor area of 20,000 sq metres and has an inventory of over 1.3 million parts. Our efficient picking and packing processes ensure we are able to meet high levels of performance and effectiveness, achieving an on-time dispatch of 99.9% and an accuracy rate of 99.87%. From our operations through to the vehicles you drive, we are committed to you.

# NETWORK

**WJ 4700**







**WESTERN STAR TRUCKS®**

---

Penske Commercial Vehicles  
Wacol, Queensland 4076  
Phone: + 61 7 3271 7777

**WESTERNSTAR.COM.AU**

