

FREIGHTLINER CORONADO. **AN INSTANT CLASSIC.**



Run Smart



TURN HEADS WHILE TURNING A PROFIT.

The new Freightliner Coronado is the perfect mix of style, performance and reliability.

With a huge stainless steel grille, square bonnet and stylish chrome air intakes, the Coronado has that classic 'Big Rig' look that will make you proud to get behind the wheel every day.

But this truck has much more than an attractive exterior. It's the perfect on-highway hauler.

The Coronado is built around a proven Freightliner core, but the addition of advanced technology and a wide range of enhancements has lifted it to a new level of excellence.

In fact, we've built it strong enough to go off-road, so it can handle anything on-road.

Profit and Safety

With the choice of two leading US engines with eight option ratings to 600 hp, the Freightliner Coronado can deliver big loads easily, and its low tare weight allows for a larger payload which can result in greater revenue.

Of course, like every Freightliner, the Coronado puts a priority on driver safety and comfort. The cabin exceeds European safety standards (ECE-R29) and is more spacious and driver friendly.

A great looking, hard working, profit machine: the Freightliner Coronado is simply the best thing to enter the Australian transport industry in years.



BUILT FOR BUSINESS.

Every aspect of the Freightliner Coronado has been designed to make it the perfect truck for on-highway applications.

Whether you're doing local, single-trailer distribution work or a major B-double line haul job, the Freightliner Coronado will do it effectively and efficiently every single day.

There's an engine available for any role, with the choice of either the Detroit Diesel DD15 or Cummins ISX powerplants with power options ranging from 485-600 hp.

Both engines are fully ADR80/03 compliant and can be upgraded without changing engine hardware.

With all that power the Freightliner Coronado can be rated for 106,000 kgs Gross Combined Mass for general highway use.

Maximum Payload

But being able to move a lot of weight is only good if you can maximise your payload. The Freightliner Coronado boasts a low tare weight starting from just 7,857 kgs, so it will provide you with bigger payloads as a result of the lighter tare weight.

A super-strong chassis built on straight, heavy duty frame rails provides the backbone. The Coronado's Meritor rear axles are rated to 20,870 kgs and the rear suspension comes in a choice of Freightliner Airliner™ or Hendrickson PRIMAXX™ airbag systems.

For the front axle, 6.35 or 6.5 tonne Meritor packages are available.

To optimise power delivery, there's a choice of transmission with either the Eaton Manual or automated transmission with Freightliner's SmartShift™ paddle mounted on the steering column.

With the days of cheap diesel well behind us, Freightliner has paid special attention to fuel economy.

Both the the Detroit Diesel DD15 or Cummins ISX engines sip fuel and this has been enhanced by a light-weight aluminium cab and a focus on aerodynamics.

The Coronado's curved windscreen is sloped at 24° to greatly reduce wind resistance. The bonnet guards, headlights, mirrors, air intakes, angled front bumper and even the bonnet handle are also designed to cut drag and may contribute to lower fuel costs.

The large cabin is designed for driver comfort, which means increased productivity, and comes in five variations from a Day Cab through to 58" raised roof two-up sleepers. All feature Freightliner's famous flat floor for easy movement and plenty of head room.



BUILT TO DRIVE.

To get the best out of a truck you have to get the best out of the driver, which is why the Freightliner Coronado has the best cabin on the road. Nothing has been overlooked.

The cab, which is up to 20 centimetres wider than most conventional cabs, exceeds rigorous European crash-worthiness standards (ECE-R29), providing a high level of driver safety.

A flat floor throughout the cab and sleeper areas make it much easier – and more pleasant – for the driver to move about.

When on the job, EzyRider II high-backed seats, a chrome and leather steering wheel that's fully adjustable, and an ergonomically designed, injection-moulded dash that puts everything in easy reach, makes driving a pleasure.

It looks good too. The interior features Oregon burl wood trim. The durable two-tone dash has ivory coloured gauges with bright bezels and the attractive interior trim comes in either studded vinyl or cloth.

Large rigid doors have double seals for superior insulation and noise reduction. Vision is excellent thanks to large side windows and rear view mirrors. And one of the best air-conditioning and heating systems in the industry will keep the driver and any passenger feeling comfortable and relaxed.

Sleep Well

On long trips, getting a good night's sleep is all-important for safety and efficiency. In the Coronado, sleeping is easy with the cab and sleeper packed with noise abatement material in the floor, front wall, sides and back panel. A separate control panel can adjust the heater, air-conditioner and lights. Strategically placed cabinets maximise storage space and a stow-away bunk in the 58" raised roof model provides extra bed space when it's needed. A clothing rack and pull-out writing surface make life easier, and there's a perfect spot for a TV.

The front cab mounts use a 'pillow block' design which effectively isolates vibration and shock from the road, while the rear mounts feature air springs mounted outside the frame rails. It all means a smooth, stable ride with the driver getting a great 'feel' for the road.



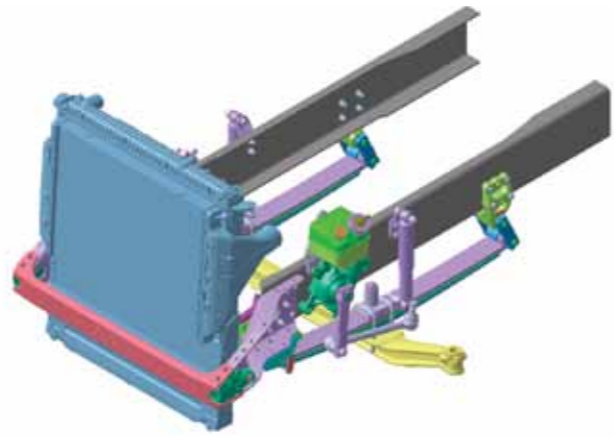

BUILT TO LAST.

A truck is only doing you good when it's on the road, so we've designed the Freightliner Coronado for high performance with minimum downtime.

The bonnet tilts almost 90° so accessing the engine for maintenance is easy. It's also a great help for daily checks of coolant, power steering fluid, and windshield washer fluid levels all throughout transport reservoirs. There's no strain either, with the Coronado's bonnet tilt mechanism reducing the lift effort to a mere 20 kgs.

The bonnet itself is made of fibreglass, so if ever necessary, it's easy to repair with 'parting lines' to assist body shops. The bonnet guards are reinforced with impact absorbing material to help eliminate damage and 'star' cracks.

The truck's stylish headlights are far superior to traditional designs, with a single high-tech reflector providing excellent front and side illumination. No tools are needed to change bulbs, just tilt the cab and pop one in.

The windshield has been designed in two-pieces, to make replacement easier and cheaper.

The electrical wires are numbered and colour-coded for easy maintenance.



BUILT TO BREATHE WITH A DAM SIZED RADIATOR.

To work hard you have to be able to breathe, whatever the weather is like outside.

The two air intakes on the side of the bonnet are both attractive and highly functional. Aerodynamically shaped, they minimise the intake of water, dust and debris, significantly extending the life of the main air filter.

Beneath the Coronado's gleaming grille sits a massive 1,900 in² engine-mounted radiator, large enough to handle the hottest conditions with reserve capacity.

BEHIND YOU **ALL** **THE WAY.**

Of course, when you buy a Freightliner Coronado you're not just getting the best on-highway truck available; you're also getting the knowledge and support of a trucking giant.

Freightliner is a core part of the largest truck company on the planet, Daimler AG, and the experience and understanding gained over decades and millions of vehicles has been funnelled into the Freightliner Coronado.

In Australia, Freightliner owners enjoy the back up of 45 Authorised Dealers across the country.

Help and spare parts are always close at hand - maintenance and warranty support is easy to access.

In case you ever need roadside support, our Customer Assistance Hotline is available 24/7. Just call 1800 033 557.

And, of course, there's our nationwide network of Freightliner dealers, whether you're in Gosford or Geraldton - or anywhere in between. Find your nearest dealer by calling 1300 66 22 30.

Daimler Truck Financial

Why Daimler Truck Financial?

Daimler Truck Financial* is the world's largest truck financier. And as the dedicated finance provider for Freightliner Trucks, our products are specifically designed with Freightliner owners in mind. This means you benefit from tailored products, backed by our industry knowledge and experience.

We offer fast finance approvals through our finance assessment team who appreciate the needs of truck buyers. Our competitive pricing and flexible finance contract terms, with the option of repayment holidays*, are just a few of the reasons why Daimler Truck Financial is for you.

As a business customer, you can tailor a plan to suit your needs from our suite of financing options.

Our Business Loans

Asset-Hire Purchase

This type of finance product provides you with flexible options. Finance agreements of this type can be structured with or without a deposit. Payments can be tailored to suit individual needs by opting for a longer term or incorporating a final balloon payment. Upon completion of the finance agreement, and following final payment, you will then have ownership of the vehicle.

Asset Loan

Asset Loan (commonly referred to as a Chattel Mortgage), is available for individuals, sole traders, partnerships and companies where ownership of the vehicle at the start of the finance agreement is important. This finance product differs from an Asset-Hire Purchase and Finance Lease in that vehicle ownership is

provided for at the start of the finance agreement, in exchange for security to be taken over the vehicle. Upon completion of the finance agreement and following final payment, security over the vehicle is released.

Finance Lease

This type of finance product is a rental agreement offering fixed payments with the addition of a residual value payable at the expiry of the finance contract. This finance product offers immediate use of the vehicle without a substantial outlay. At the end of the finance lease you can make an offer to purchase, re-lease, or upgrade to a brand new vehicle – the choice is yours.

Our finance products may provide taxation advantages depending on the structure of your business†.

Our Finance Product Features: With all of our finance products you benefit from:

- **Flexible Terms** - 12-60 months for all Freightliner Trucks
- **Final Balloon Payment / Residual Value** - We offer this structure on all finance contracts
- **Fixed interest rates with no ongoing monthly fees** - Your interest rate is fixed for the duration of the loan term
- **Structured Payments**- We can tailor payments to suit your cashflow requirements

*Daimler Truck Financial is a registered business name of Mercedes-Benz Financial Services Australia Pty Ltd ACN 074 134 517 (MBFSAU). MBFSAU offers finance products for new and used vehicles (up to 8 years). All finance products offered are/may be subject to conditions and standard credit assessment criteria. You should contact an authorised dealer for further details.
†Interest will continue to accrue during any holiday repayment period.
‡MBFSAU makes no representation as to the effect of any financial product on your personal or company tax arrangements and recommends you seek independent financial and taxation advice before entering into any finance agreement.



Freightliner Dealerships

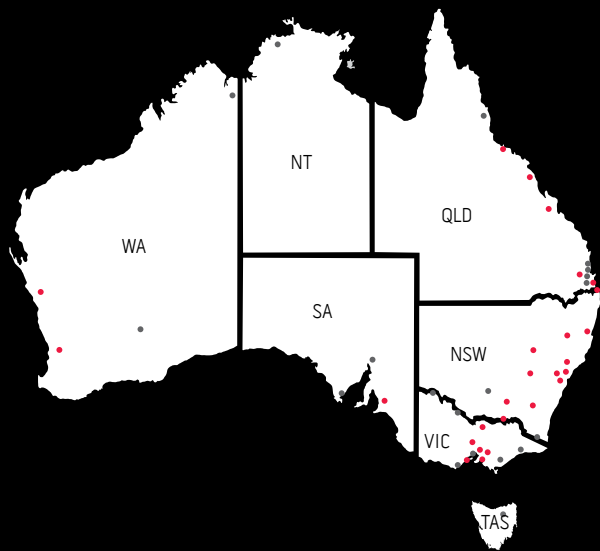

- Sales, Service and Parts Dealer
- Service and Parts Only Dealer

NSW

- Dubbo
- Gosford
- Griffith
- Huntingwood
- Kempsey
- Lavington
- Milperra
- Murwillumbah
- Newcastle
- Orange
- Pambula
- Queanbeyan
- Tamworth
- Wagga Wagga

SA

- Angle Park
- Port Augusta
- Port Lincoln

NT

- Berrimah

WA

- Geraldton
- Kalgoorlie
- Kununurra
- Perth

QLD

- Arundel
- Burleigh Heads
- Caboolture
- Mackay
- Portsmith
- Rockhampton
- Rocklea
- Toowoomba
- Townsville
- Woombye

VIC

- Bendigo
- Colac
- Dandenong
- Footscray
- Geelong
- Kilsyth
- Lakes Entrance
- Laverton
- Mildura
- Shepparton
- Somerton
- Swan Hill
- Traralgon

TAS

- Rocherlea

Contact your local authorised Freightliner Dealer on **1300 66 22 30**.

Daimler Trucks offers a standard 2 year/ unlimited kilometre driveline Warranty on transmission, driveshafts and driving axles.

For full Warranty details and limitations contact your authorised Freightliner Dealer. Specifications and information referred to herein were correct at the time of publication. Some of the equipment depicted either on vehicle illustrations or separately may be non-standard or optional at extra cost.

Daimler Trucks reserves the right to discontinue or modify any vehicle or optional equipment at any time without prior notice to meet any requirement of a manufacturing or commercial nature which it may deem appropriate.

Consult your authorised Freightliner Dealer for the latest details on specifications, options, prices and availability.

Freightliner is a registered trademark of Daimler Trucks North America LLC.

Daimler Truck Financial

Helping you evaluate which finance plan or lease best suits your budget.

Call 1300 730 200



Quality Safety Service

Genuine Parts & Service

With Freightliner Service Centres all across the country, maintenance and simple warranty service is convenient and accessible, maximising uptime.

Call 1300 323 722

Your authorised Freightliner Dealer is:



www.freightliner.com.au

Daimler Trucks, a division of Mercedes-Benz Australia/Pacific Pty Ltd, ABN 23 004 411 410.
44 Lexia Place (PO Box 4214) Mulgrave, Victoria 3170. Telephone: (03) 9566 9266 Facsimile: (03) 9562 6282

LMCT6776 • FLS013 05/11