



WESTERN STAR TRUCKS®





## VERSATILITY AT ITS BEST

---

The 4800 is designed to be versatile. When you're managing a fleet, this model is ideal as you can change your freight requirements season-to-season without changing your truck type. The 4800 gives you the ability to get the maximum payload on anything from a truck and dog to road trains up to 140 tonnes – with engine ratings up to 600hp. This Star can handle the big loads and look good while at it. Its cab is spacious and air-suspended, is easy to enter and exit, and also has a sizeable window in the left-hand door for increased visibility. The perfect all-rounder for the job, this Star can work alone, or fits well in any fleet.



# LET'S GET SERIOUS







## A VERSATILE LEGEND

In the modern world, multi-tasking is essential. Especially when you're managing a transport business. The 4800 is designed to give you plenty of options, and it will meet the challenges of your business with ease. Fantastic fleet members, this prime mover also performs well on its own. Like any great Stars, these are versatile. And more importantly to you, and your business, this model delivers.



## LONG-HAUL LEADER

The 4800 is one powerful machine that has been specifically built to meet the 26-metre, B-Double regulation. It's with you for the long-haul. This bonneted truck has been handcrafted with a spacious cabin, plenty of storage and working space, and all the comforts you need. A dependable working Star.

# TEAM PLAYER & SOLO HERO

WJ 4800





**YOU ASKED,  
YOU GOT IT**

Western Star is all about choice and the 4800 is no exception. Power your prime mover with the engine of your choice. You can opt for a Detroit DD13, DD15, or a Cummins X15. This power of choice combined with Western Star's inherent efficiency means you are poised to profit whatever you decide.

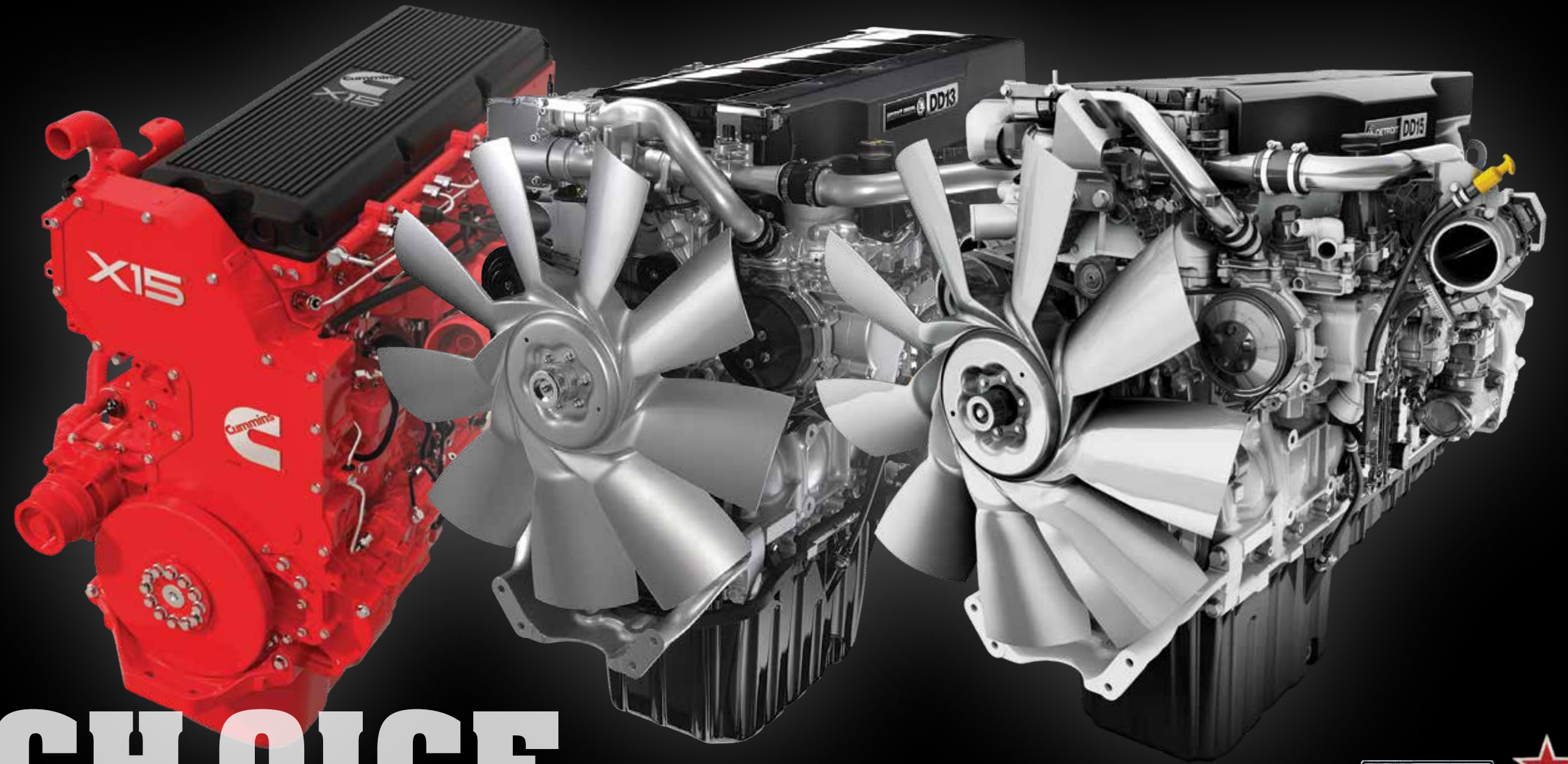

**THE POWER OF CHOICE**

**W 4800**





## COMFORT IN SPADES

The most versatile model in the Western Star line-up, the 4800 is available with sleeper and day cab configurations. The roomy, full-width, walk-through cabin gives occupants a spacious environment, while offering ample storage options. The functional dashboard control panel ensures everything is at your fingertips, leaving you to concentrate on the task at hand.

# ROOM TO SPARE

W 4800





# SPECIFICATIONS

## WESTERN STAR 4800 (6X4 - DAY CAB)\*

|                  |  |
|------------------|--|
| Engine           | Detroit DD13 or DD15 / Cummins X15   |
| Transmission     | Eaton Manual and Ultrashift  |
| Front Suspension | Tapered leaf with flat leaf option.<br>Ratings: 6,500kg std. Option: 7,500kg |
| Rear Suspension  | Airliner 40/46k, Neway, Tuff Trac. Ratings: 40,000lb-52,000lb                |
| Front Axle       | Meritor MFS73 option FG941. Capacity: 6,500-7,300kg                          |
| Rear Axle        | Meritor, Dana Spicer. Capacity: 40,000lb-52,000lb                            |
| GVM              | 26,000kg   |
| GCM              | Up to 140,000kg  |
| Wheelbase        | Optional wheelbases available  |
| Cab Options      | Detroit: Day Cab   |
|                  | Cummins: Day Cab   |

## WESTERN STAR 4800 (6X4 - SLEEPER CAB)\*

|                  |  |
|------------------|--|
| Engine           | Detroit DD13 or DD15 / Cummins X15   |
| Transmission     | Eaton Manual and Ultrashift  |
| Front Suspension | Tapered leaf with flat leaf option.<br>Ratings: 6,500kg std. Option: 7,500kg |
| Rear Suspension  | Airliner 40/46k, Neway, Tuff Trac. Ratings: 40,000lb-52,000lb                |
| Front Axle       | Meritor MFS73 option FG941. Capacity: 6,500-7,300kg                          |
| Rear Axle        | Meritor, Dana Spicer. Capacity: 40,000lb-52,000lb                            |
| GVM              | 26,000kg   |
| GCM              | Up to 140,000kg  |
| Wheelbase        | Optional wheelbases available  |
| Cab Options      | Detroit: 34" low roof, 34", 40", 54" and 68" Stratosphere                    |
|                  | Cummins: 40" and 54" Stratosphere  |

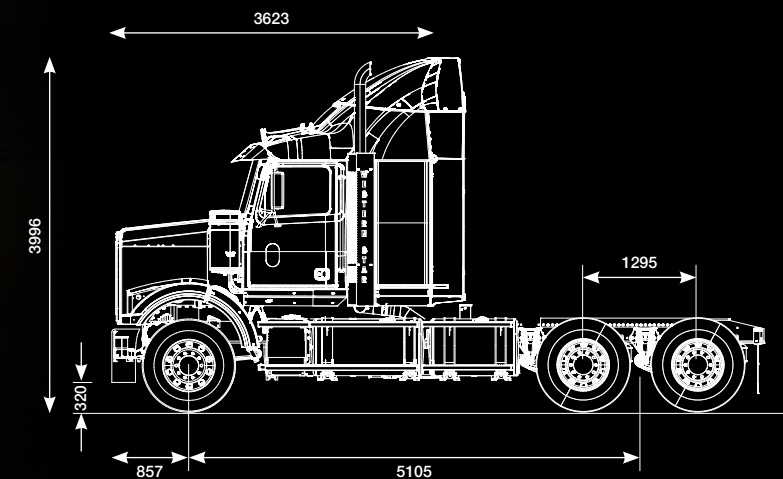
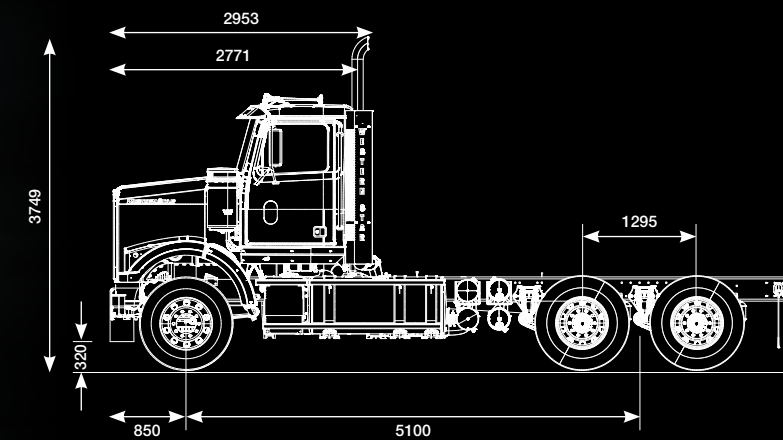

W 4800



\*Specifications subject to change based on state regulations.





# SUPPORT

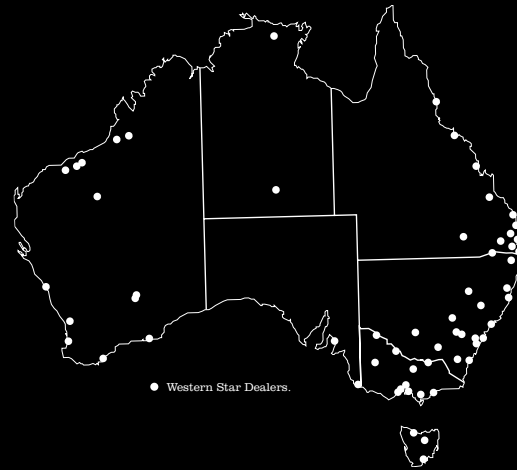

• Western Star Dealers.

## BACKED BY PENSKE

Penske Commercial Vehicles is the exclusive importer and distributor of Western Star Trucks, MAN Truck & Bus, as well as Dennis Eagle Trucks across Australia and New Zealand. Penske Commercial Vehicles is a subsidiary of Penske Automotive Group, a worldwide leader in automotive retail and transportation services, operating automotive and commercial truck dealerships in the United States, Canada and Western Europe, and employing more than 26,000 people globally. With a network of 70 company-owned and independent dealers across Australia and New Zealand, Penske Commercial Vehicles provides full authorised parts, service and warranty functions. No matter where your job takes you, there will be a Western Star dealer nearby ready to help.

WJ 4800







# PENSKE DISTRIBUTION CENTRE

In addition to our extensive network of 70 dealers across Australia and New Zealand, customers are also fully supported by the Penske Distribution Centre (PDC). Located in Wacol, QLD, our state-of-the-art PDC comprises a total floor area of 20,000 sq metres and has an inventory of over 1.3 million parts. Our efficient picking and packing processes ensure we are able to meet high levels of performance and effectiveness, achieving an on-time dispatch of 99.9% and an accuracy rate of 99.87%. From our operations through to the vehicles you drive, we are committed to you.

# NETWORK

**WJ 4800**







---

Penske Commercial Vehicles  
Wacol, Queensland 4076  
Phone: + 61 7 3271 7777

**[WESTERNSTAR.COM.AU](http://WESTERNSTAR.COM.AU)**