

BALENO



Way of Life!



UP FOR ANYTHING

The decision between reason and emotion has never been easier. Choose both at the same time with The Baleno.

With its stunning design, The Baleno makes you the centre of attention, at every turn and corner.

The Baleno makes an impression with its versatility. Ideal companion to drive you through life's exciting moments.

STYLE FOR EVERY TASTE

The versatile styling of The Baleno catches everyone's eye. The Baleno hatchback is inspired by the design concept of "Liquid Flow". Its low and wide stance, along with harmoniously flowing curves on its body give it an elegant yet powerful look. At the same time, the car's frontal design adds a sporty vibe to it, making its style appealing to all.



CAPTIVATING FROM WITHIN

The Baleno is not just about outer beauty. As you enter the car you will notice that its elegant styling extends into the interior of the car. Its cabin is lined with high quality silver ornaments, which add a touch of sophistication, leaving you spellbound.



Smartphone Linkage Display Audio (SLDA)

With Smartphone Linkage Display Audio, you can enjoy intuitive operation of multimedia features including audio, hands free phone and smartphone integration. The Smartphone Linkage Display Audio works with Apple CarPlay®, Android Auto™ and Mirrorlink™.*which allows the use of various smartphone applications.



Apple CarPlay® is available in the countries listed at the following link: <http://www.apple.com/ios/feature-availability/#applecarplay-applecarplay>
 *For more details including iPhone® models compatible with Apple CarPlay® see: <http://www.apple.com/ios/carplay/>
 *Apple®, Apple CarPlay® and iPhone® are trademarks of Apple Inc., registered in the U.S. and other countries
 *Android Auto™ is available in the countries listed at the following link: <https://www.android.com/auto/#hit-the-road>
 *Requires the Android Auto™ app on Google Play™ and an Android™ compatible smartphone running Android™ 5.0 Lollipop or higher: <https://support.google.com/androidauto/#6140477>
 *Android™ and Android Auto™ are trademarks of Google LLC.
 *MirrorLink™ is compatible with the smartphones listed at the following link: <https://cert.mirrorlink.com/Productlisting/>
 *Mirrorlink™ is a registered trademark of the car Connectivity Consortium LLC.



Advanced multi-information display (GLX)

At the centre of the instrument cluster lies the information display, which keeps you informed about your driving status. Equipped with a 4.2" colour LCD screen, it allows you to keep track of fuel efficiency, engine output, average vehicle speed and other driving results whenever you want.

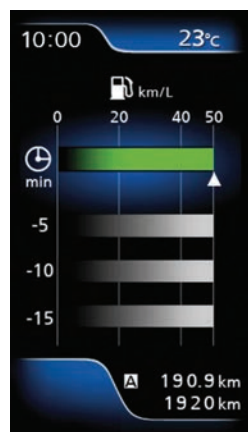

Displays travelling fuel efficiency and average past fuel efficiency.

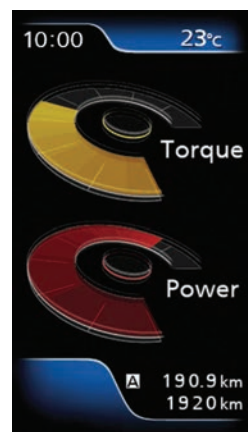

Displays power and torque in real time.

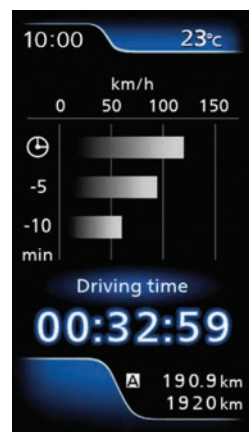

Displays average vehicle speed and average past vehicle speed.



Indicates proximity to objects when rear parking sensor is in operation.

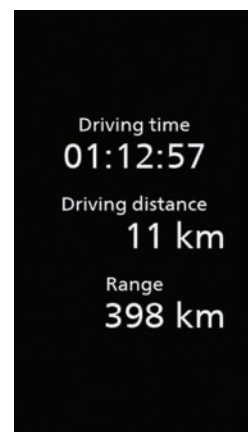

Displays driving time, driving distance from engine - on to engine - off and distance to refueling.

Air Conditioner

The air conditioner control panel allows easy operation. High-contrast LCD on the automatic air conditioner (GLX) makes the operation intuitive. The manual air conditioner (GL) has simple controls for operational convenience.



Automatic Air Conditioner

Manual Air Conditioner



Cruise Control

Enjoy the convenience of cruise control system by keeping the car moving at a set - speed, reducing driver effort during long-distance drives.



COMFORT IN EVERY MOMENT AND EVERY DRIVE

Whether it's a long drive or a quick spin in the city, The Baleno ensures unmatched comfort. The fine texture fabrics and elaborate patterns used for the seats create a calm and soothing experience in the cabin.



The Baleno has ample leg and shoulder room, giving the driver and passengers space to relax, and the multiple compartments add to the practicality. It's 355L* luggage space allows sideways storage of long items, and by folding down the rear seats, it can accommodate even more space to provide ample room for all your items. As an added amenity, a luggage shelf ensures privacy.

* Luggage space measured using the German Association of the Automotive Industry (VDA) method.



Vanity mirror



Glove Box



Front accessory socket and USB port



Front door pocket with bottle holder

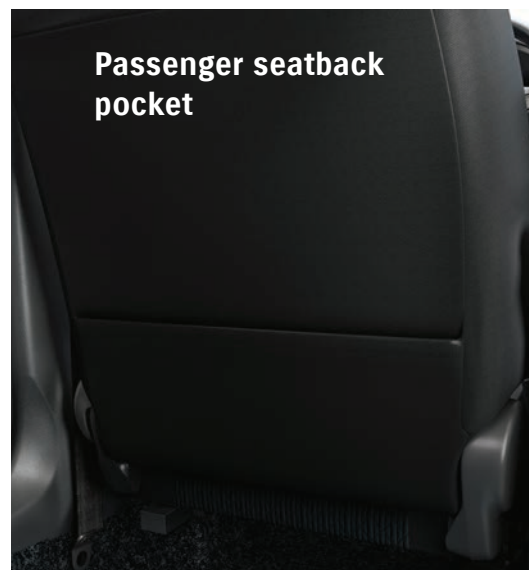

Passenger seatback pocket



Rear door pocket with bottle holder



Console box With armrest (GLX)



Driver's side pocket



Rear accessory socket



Tray with removable partition



POWERED TO MAKE EVERY DRIVE EXCITING

The Baleno is an exceptional performer. Every part of the car is equipped to ensure maximum efficiency and comfort. That's why when you take it for a drive, it's always an extraordinary experience.



Transmission

No matter which transmission you prefer, The Baleno ensures a relaxing and efficient drive. The 4-speed automatic transmission delivers powerful acceleration at low speeds and fuel efficiency at high speeds. The 5 speed manual transmission (GL) provides smooth and precise shift feel, for a more enjoyable and nimble drive.

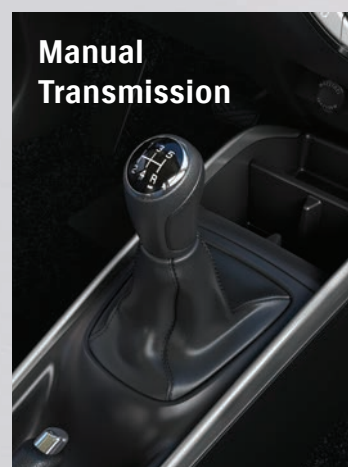

Manual Transmission



Automatic Transmission

1.4L ENGINE

Designed to deliver maximum energy efficiency, the engine delivers strong power, while ensuring fuel efficiency. The intake VVT, cylinder head and piston crowns are designed to boost fuel economy, which is enhanced by a great aerodynamic body.



ENHANCED SAFETY FOR A PLEASANT DRIVE

Drive from one exciting moment to another, knowing that you are well protected. The Baleno is equipped with advanced safety features such as occupant-protective airbags and anti-lock braking system to enhance your daily peace of mind.



HEARTECT

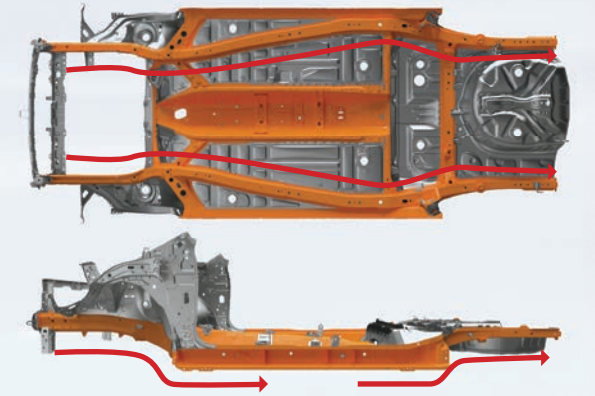
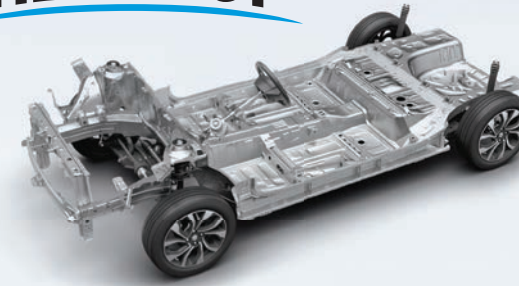

Light and Rigid "HEARTECT" platform

The Baleno enhances your driving experience, thanks to its new-generation platform – HEARTECT. Light and highly rigid, it lowers fuel consumption and vastly improves the fundamental vehicle performance in terms of running, turning and stopping. Its frame is characterised by smooth and continuous curves, which efficiently disperses impact energy in case of a collision.

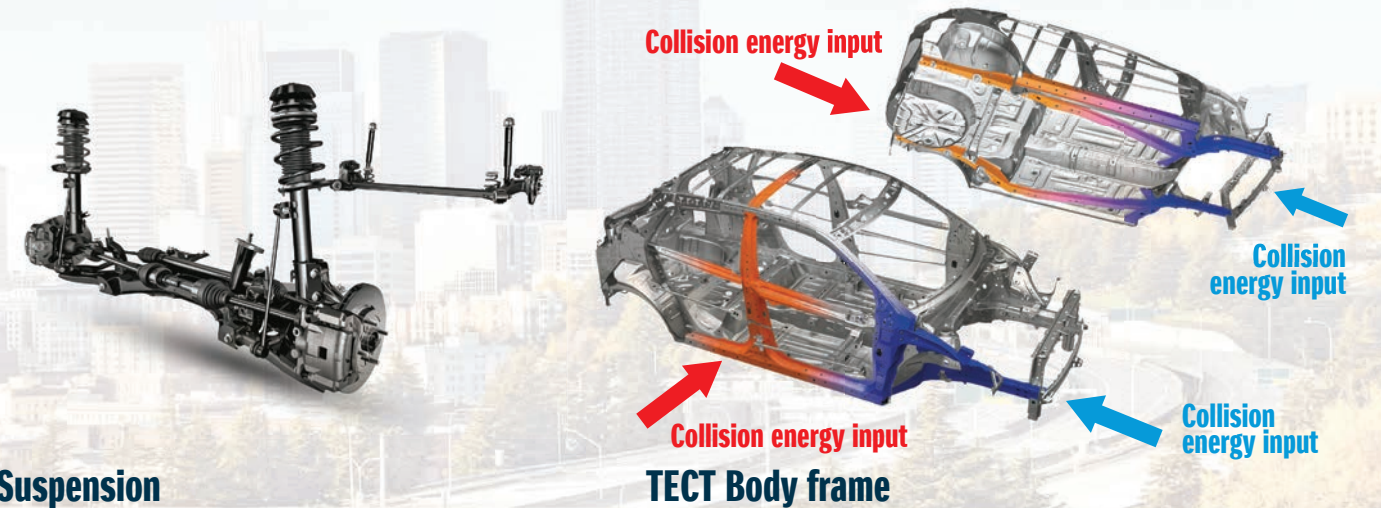

Suspension

The Baleno takes on every road with equal ease. The highly tuned suspension ensures solid cornering and responsive handling, while assuring a relaxing, smooth drive.

TECT Body frame

Suzuki TECT (Total Effective Control Technology) Body helps protect the cabin in the event of a collision by efficiently absorbing and dispersing energy. It also widely employs high tensile steel to achieve both lightness and excellent safety performance.

Braking Assistance

In an emergency braking situation, an Anti-lock Brake System (ABS) keeps tyres from locking up and adds stability to evasive maneuvers. In addition, a braking assistance function augments stopping power, while Electronic Brake force Distribution (EBD) helps maintain control by sending the optimum amount of force to the front and rear wheels.

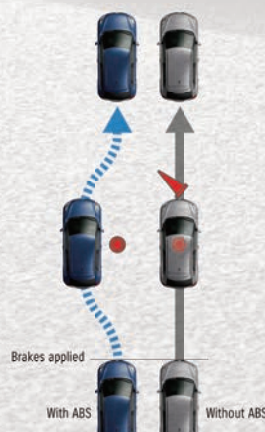

ESP®

Should the wheels lose traction, the Electronic Stability Programme ESP®* automatically adjusts the engine and brakes to help keep the driver in control.

*ESP is a registered trademark of Daimler AG.

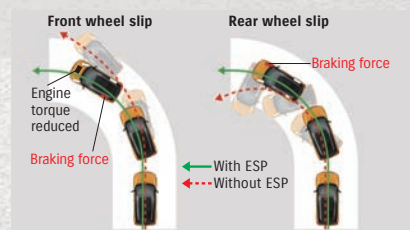

Pedestrian protection

To mitigate pedestrian injuries in the event of a collision, the Baleno's bonnet, cowl top, wipers and front bumper are designed to absorb impacts.



Occupant – protective SRS airbag system

To protect not only the driver, but also the front – passenger, both the driver's seat and front passenger's seat come standard with SRS airbags. Furthermore, curtain and side airbags (GLX) help reduce further impact for enhanced safety.



Rear parking sensors

Ultrasonic sensors in the rear bumper detect obstacles and issues audio – visual warning to the driver.



Way of Life!

Suzuki's "Way of Life!" is the heart of our brand - every Suzuki vehicle, motorcycle and outboard motor is built to create excitement so customers can enjoy everyday life.



www.suzukiqld.com.au

All care is taken to ensure the accuracy of this brochure at the time of publication approval. Specifications, features, prices and model availability may vary from State to State and may change without notice. Always consult your authorised Suzuki Dealer or refer to www.suzukiqld.com.au for the latest details on all models. SUZUKI will not be held liable for any loss as a result of reliance on the content of this brochure, whether in negligence or otherwise. Vehicles are shown for illustrative purposes only and may not depict exact Australian specifications. Published July 2019.