



The new Actros

4x2 Prime Mover
M-Cab ClassicSpace
1835, 1840, 1843, 1846

Mercedes-Benz
Trucks you can trust



4x2 Prime Mover

M-Cab ClassicSpace

The extensive range of Mercedes-Benz Actros Prime Movers set a new standard in long-distance and heavy duty distribution haulage. Designed to meet modern business needs, each model is equipped with innovations for enhanced efficiency, exemplary reliability and unique comfort. The new Actros is a star-quality truck ahead of its time.

Models at a glance

Model	Engine and transmission	Cab	Weight front	Weight rear
Actros 1835	OM 936, 354hp + G140-8	M-Cab Classic 2.3 with 320mm tunnel	4,211	1,766
Actros 1840	OM 470, 394hp + G211-12	M-Cab Classic 2.3 with 320mm tunnel	4,632	1,832
Actros 1843	OM 470, 428hp + G211-12	M-Cab Classic 2.3 with 320mm tunnel	4,632	1,832
Actros 1846	OM 470, 455hp + G211-12	M-Cab Classic 2.3 with 320mm tunnel	4,632	1,832

Weights include full AdBlue, 75kg driver, no fuel.



M-Cab ClassicSpace 2.30m, tunnel 320mm

Model Specifications

Engine

Engine Model	OM 936	OM 470	OM 470	OM 470
Capacity	7.7l	10.7l	10.7l	10.7l
Power	260kW (354hp)	290 kW (394 hp)	315 kW (428 hp)	335 kW (455 hp)
Touque	1400Nm (1,033 ft.lb)	1900Nm (1,401 ft.lb)	2100Nm (1,549 ft.lb)	2200Nm (1,623 ft.lb)

Cab

Multimedia cockpit

Truck navigation

Digital radio

Driver's suspension seat, comfort

Fold-up co-driver's seat

Air conditioning system

Windscreen, tinted, with filter band

Optional equipment

- Co-drivers suspension seat, comfort
 - Leather seats¹
 - StyleLine interior²
 - Automatic climate control
 - Cab rear wall without window
 - Roof deflector and cab side deflectors
 - External sunvisor
 - MirrorCam
 - Two additional remote control keys
 - Multimedia cockpit, interactive
 - Toolkit
 - Internal yellow grab handles
 - Weathershield, driver and passenger side
-

Driveline

G140 - 8 speed PowerShift Transmission with single plate clutch and 3.909 RAR engine RPM 1,589 @ 100km/h

G211 - 12 speed PowerShift Transmission with single plate clutch and 2.846 RAR engine RPM 1,472 @ 100km/h

Optional equipment

- Predictive Powertrain Control
 - Power Take Off (PTO) MB 131-2c, pump
-

Front axle and suspension

7.5t offset front axle with 7.5t two leaf springs

Rear axle and suspension

13.0t hypoid rear axle with differential locks

Four bag rear air suspension

Axle load measuring device

Brakes

Disc brake, with Electronic Braking System (EBS)

Anti-lock Braking System (ABS)

Traction Control System (ASR)

Electronic Stability Program (ESP)

Independent trailer brake

High performance engine brake

Electronic park brake

Optional equipment

- Independent trailer brake, electronic
-

Wheelbase and frame

3700mm wheelbase with 1050mm tapered rear overhang

Factory 5th wheel non drill angles

Local 5th wheel pre drilled angles on 460hp models

Optional equipment

- Wheelbase 4000mm
 - Jost JSK37 turntable
 - Jost JSK37 sensor TT-260 OAH
 - Pogostick
-

Electrical

Rear of frame integral battery carrier

100A alternator with two 220 Ah AGM batteries

2nd generation PSM (Body Interface Module)

Mercedes-Benz Telematics hardware and MB Uptime Assist

Mercedes-Benz Telematics 12 month complimentary access

Fleet Management System (FMS)

Bi-xenon headlamps

LED daytime runnings light + LED tail light

Air horn, below cab

Optional equipment

- Air horn, cab roof mounted
 - Comfort telephony, wireless charging
 - Pre-installation and display for up to four cameras
 - Pre-installation for rotating beacons
 - Pre-installation for additional headlamps, roof
 - Three switches for non-MB body electrics
 - 12V trailer lighting voltage reducer
 - UHF radio GME TX4500S
 - UHF radio GME XRS370C
-

Safety

Driver airbag

Seat belt monitor

Rain sensor

Light sensor

Optional equipment

- Safety Pack, inclusive of Lane Keep Assist, Attention Assist, Active Brake Assist 5, Proximity Control Assist and automatic main/dipped beam and cornering light
 - Tyre pressure monitor
-

Fuel, Adblue and exhaust

390l aluminium fuel tank left hand side

60l Adblue tank left hand side

Exhaust system, tailpipe to right and outwards

Optional equipment

- Second tank, 290l, right hand side³
-

Wheels and tyres

8.25" x 22.5" steel rims with 295/80R 22.5 tyres

Optional equipment

- 8.25" x 22.5" Dura-Brite rims
 - Spare rim and tyre
-

Maximum weights

OM 936 - 18,000kg GVM, 36,000kg GCM

OM 470 - 18,000kg GVM, 46,000kg GCM

Warranty

2 year bumper to bumper with 4 year/800,000km driveline warranty

Chassis drawing and dimensions

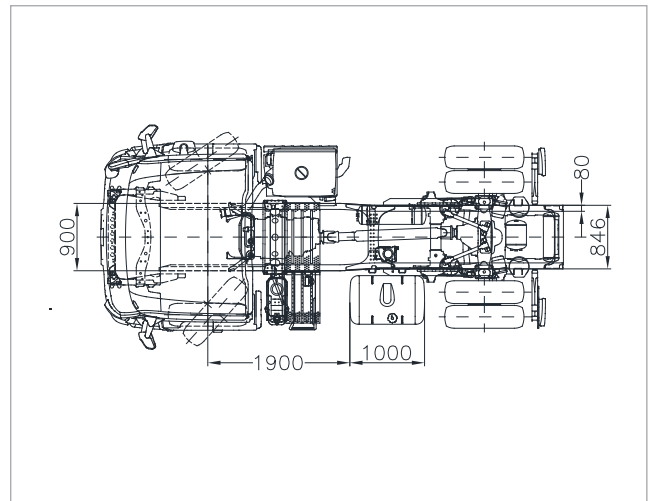
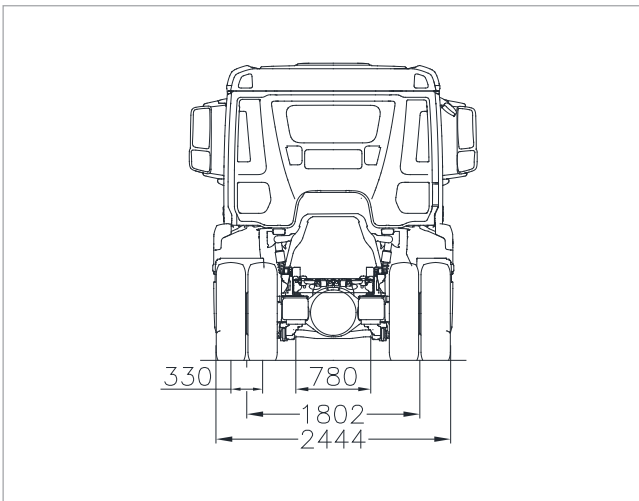
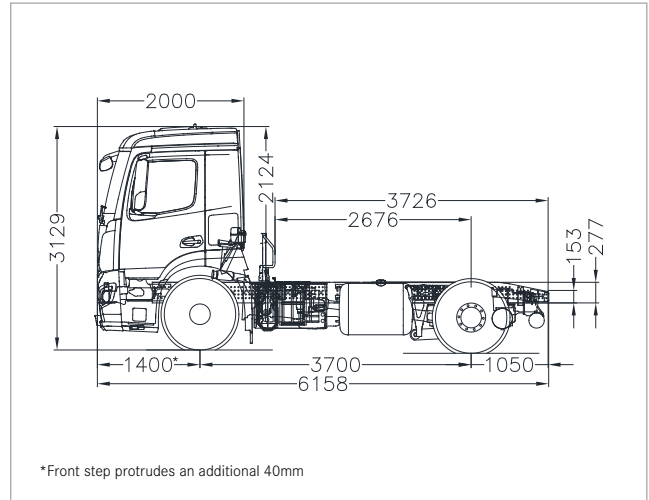
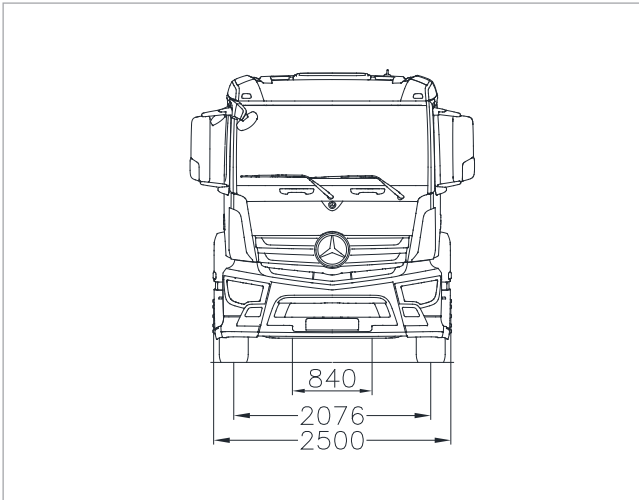

¹ Only available with co-drivers suspensions seat, comfort

² Only available with independent trailer brake, electronic

³ Only with OM470 engine

Please note: changes may have been made to the product since this publication went to press (May 2020). The manufacturer reserves the right to make changes to the design, form, colour, and specifications to the vehicles or optional equipment without notice, including during the delivery period. The illustrations and texts may include accessories and items of special equipment which are not part of standard specification. Colours may differ slightly from those shown in the brochure, owing to the limitations of the printing process. The images shown are to be considered examples only and do not necessarily reflect the actual state of the original vehicles. The appearance of the original vehicles may differ from these illustrations. Subject to change. This publication may also contain models and services which are not available in certain countries. This brochure is distributed internationally. It provides a general indication of the range of models, features, special equipment and/or colours available in various countries. Some of the models, features, special equipment and/or colours may not be available in your country, or may only be available in a different specification. Additionally, some models, features, special equipment and/or colours may only be available in combination with others. Some equipment depicted either on vehicle illustrations or separately may be non-standard or options and may, where applicable, be available at an additional cost. For current and more specific information on the availability, design features and prices of all models, features, optional extras and/or colours available in Australia or New Zealand, you should contact your authorised Mercedes-Benz Truck Dealer on 1800 033 557 or go to https://www.mercedes-benz-trucks.com/en_AU (Australia), or https://www.mercedes-benz-trucks.com/en_NZ (New Zealand).
Daimler Truck and Bus Australia Pacific Pty Ltd. Mulgrave, Victoria, Australia. ACN 618 413 282. Printed in Australia.