

# CANTER 815 TIPPER

4X2 / LSD / MANUAL OR DUONIC AMT

GVM

**7,500KG**

GCM

**10,000KG**

Power/Torque

**110KW/370NM**

Light rigid licence required.

Can be derated and driven with a passenger car licence.



**5**  
YEAR WARRANTY

ONLY JAPANESE FACTORY TIPPER WITH A LIMITED SLIP DIFFERENTIAL.

fuso.com.au

**FUSO**

# SPECIFICATIONS

## MODEL

A	4x2 815 Wide Cab Tipper SWB 6 Sp. AMT (FEC81CR3SFAC)
B	4x2 815 Wide Cab Tipper SWB 5 Sp. MAN (FEC81CR4SFAC)

## WHEEL BASE

2800mm
2800mm

## GVM (optional)

7,500kg (4,500kg)
7,500kg (4,500kg)

## GCM (optional)

10,000kg (8,000kg)
10,000kg (8,000kg)

## ENGINE

Engine Version	FUSO 4P10-T4 Diesel
Configuration	4 Cyl. In-line DOHC, 4-Valve
Type	Variable Geometry Turbo Charged Air to Air Intercooled
Displacement	3 litre (2998cc)
Bore	95.8mm
Stroke	104mm
Power (DIN)	110kW @ 2840~3500 rpm
Torque (DIN)	370Nm @ 1350~2840 rpm
Maximum Engine Speed	4100 rpm
Compression Ratio	17.5:1
Cooling System / Oil Cooler	Water cooled, 13.7L capacity/ Plate type engine oil cooler
Air Cleaner	Paper Element Type with Restrictor Indicator. Vertical Intake Mounted on Clean Air Side (RH)
Emission Control	Diesel Particulate Filter (DPF) Exhaust Dash Display DPF Status 0~9 (Empty~Full) Parked Regeneration possible from 7~9
Emission Level	ADR 80/03 & EEV rated (Enhanced Environmentally-Friendly Vehicle) Euro 5

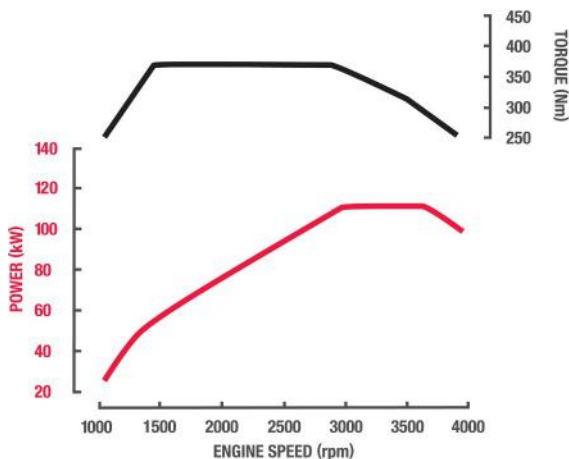

## FUEL

Injection System	Bosch Common Rail Direct Injection Bosch Piezo Technology Injectors
Tank Type	Rectangular Steel Tank with Locking Cap
Fuel Capacity *	100 Litres
Filtration	Filter with Water Separator and Indicator Sensor
Notes	*Max Fill to approx 95% of Air Capacity

## COOLING

Fan Drive	Thermo modulated continuous control (Viscous)
Radiator	Corrugated Fin with Expansion Tank

## ELECTRICAL

Voltage	12V Negative Earth
Alternator Capacity	12V-110 amp
Starter Capacity	12V-2.0kW
Battery Capacity	2x12V, 70Ah/5hr
Battery Specification	115D31LX2
Headlamp Type	Halogen
Headlamp Capacity	2x55W/60W

## CLUTCH

Clutch Model	A	Duonic Automated	B	FUSO C4W30
		Manual (no clutch pedal)		
Type	Dual Clutch (Wet Multi-plate)		Single Dry Plate, Direct Hydraulic Type	

## TRANSMISSION

Version	A	FUSO Duonic M038S6	B	FUSO M038S5
Type/Speeds	6 Speed Automated Manual with Auto and Manual Modes		5 Speed with In-Dash Gearshift Lever	
Features	Virtually Instant Gear Changes In-Dash Gear Lever with Park Brake Position ECO Mode to Minimise Fuel Usage		Synchromesh 2nd-5th	
Ratios	1st: 5.397 2nd: 3.788 3rd: 2.310 4th: 1.474 5th: 1.000 6th: 0.701 Rev. 5.397		1st: 5.494 2nd: 3.193 3rd: 1.689 4th: 1.000 5th: 0.723 Rev. 4.494	
PTO Opening	LH Side Direct Connection Pump.		LH Side Direct Connection Pump	

## FRONT AXLE

Axle Version	FUSO F350T
Type	Reverse Elliot "I" Beam
Capacity *	3100kg
Notes	*See MAX LOADING for vehicle capacity.

## FRONT SUSPENSION

Type	Multi-Leaf with Double Acting Shock Absorbers
Size	1150x70mm Leaves

## REAR AXLE

Type	Full Floating Banjo Type with Positive Locking Limited Slip Differential (LSD).	
Axle Version	FUSO R035T	
Capacity*	6000kg	
Ratio	A	B
	5.714:1	5.285:1
Notes	*See MAX LOADING for vehicle capacity.	

## REAR SUSPENSION

Type	Steel Suspension
Details	Semi-Elliptic Leaf with Double Acting Shock Absorbers
Size Main Leaves	1250x70mm
Size Helper Leaves	880x70mm

## MAX LOADING

Front	3100kg
Rear	6000kg
Total	7500kg

# SPECIFICATIONS

## MODEL

A	4x2 815 Wide Cab Tipper SWB 6 Sp. AMT (FEC81CR3SFAC)
B	4x2 815 Wide Cab Tipper SWB 5 Sp. MAN (FEC81CR4SFAC)

## WHEEL BASE

2800mm
2800mm

## GVM (optional)

7,500kg (4,500kg)
7,500kg (4,500kg)

## GCM (optional)

10,000kg (8,000kg)
10,000kg (8,000kg)

## OPTIONS

Options	H31: 4500/8000kg GVM/GCM Rating
---------	---------------------------------

## STEERING

Type	Integral Ball and Nut Type
Steering Column	Tilt/Telescopic Adjustable
Power Assist	Standard

## BRAKES

Type	Hydraulic Dual Circuit with Front and Rear Discs Twin Calliper Front and Rear
Size Front	310x40mm
Size Rear	310x40mm
Features	ABS plus EBD (Electronic Brake Distribution) Exhaust Brake Brake Priority System
Park Brake	Transmission Mounted

## WHEELS & TYRES

Wheel Type	7 x Single Piece Disc Rims (Including Spare)
Wheel Size	17.5x6.0-127
Wheel Stud Pattern	6 Stud 222.25 PCD
Tyre Size Front	215/75R17.5 124/123
Tyre Size Rear	215/75R17.5 124/123
	LUG Tyres Fitted (for Extra Traction)
Spare Tyre Carrier	Provided

## CHASSIS

Type	Tapered Frame with Body Sub-frame
Size	212x65x6mm
Tensile Strength	540 MPa

## INSTRUMENTS

Gauges	Speedometer with Odometer Tachometer Fuel Level Water Temperature
Colour Information Display	Fuel Consumption DPF Bar Chart from 1~9 Water Temperature Maintenance Reminder System Tripmeters

## MULTI-MEDIA PACKAGE

Satellite Navigation	Maps with heavy vehicle weight, length, height & hazardous material selectable restrictions with 3 years of Map updates
Colour Display	6.1 inch LCD with touch screen control
Phone Connectivity	Bluetooth® hands free
Audio Visual Entertainment	CD/DVD player and Digital radio DAB+ (also AM/FM for areas not covered by DAB+) USB port for iPod®* & other devices
Reversing Camera Compatible	Display can accept up to 3 cameras#
Notes	* iPod® compatibility requires an additional licensed cable # Cameras available through spare parts

## STANDARD FEATURES

Airbag(s)	Dual Air Bags and Seat Belt Pre-Tensioners (Driver & Far Side Passenger)	
Cruise Control	A Yes	B No
Hill Start System	Yes	
Cab Cooling & Heating	Air Conditioner / Heater / Demister	
Accessory Power	12V Accessory Power Outlet / Cigar Lighter	
Driving	Fuso Multimedia Unit Keyless Central Locking Electric Windows Cup Holders (2)	
Storage	Dual Overhead Storage Pockets In-Dash Centre Document Storage Door Storage Pockets Dash Storage Tray (1 DIN) Coat Hooks	
Cab: External	Front End-Outline Marker Lamps Door Side Impact Beams	
Chassis	Reverse Warning Buzzer Factory Reverse Camera with Infrared Display and Audible Pickup (Supply only in Cabin with Cab Chassis)	

## CAB FEATURES

Type	All Steel Forward Control Manual Tilt
Cab Structure	ECE-R29 European Cab Strength Approved
Mounting	Hydroelastic 4 Point
Additional Engine Access	N/A
Colour	Natural White
Windscreen Wipers	2 Speed + Intermittent Cycle with Integrated Washer Nozzles
Rear Vision Mirrors	1 x Internal 2 x External Convex (ECE 46) - Heated
Seating Capacity	3
Seat Belts	Lap Sash Belts for Outside Seating Positions Lap Belt for Centre Seat
Seat (driver)	Suspended with Weight Adjustment, LH Arm Rest and Lumbar Support
Seats (passenger)	Flat Folding, 2 Passenger Bench

## SERVICE INTERVALS

Interval*	30,000km, 12 Months or 600 Hours (whichever occurs first)
Notes	* based on normal operating conditions and may be reduced when operating under severe conditions.

## WARRANTY

Basic/Powertrain	5 Years, 200,000kms or 4,000 operating hours (whichever occurs first)
------------------	---

## PERFORMANCE

	A	B
Turning Circle (kerb to kerb - metres)	10.4	10.4
Road Speed (km/h) at Max Engine Speed	127	130
Engine Speed (rpm) at 100km/hr (top gear)	2817	2687
Gradeability at Rated GVM (theoretical)*	31%	29%
Notes	*This is theoretical performance only. Actual performance may vary under different conditions	

# SPECIFICATIONS

## MODEL

- A** 4x2 815 Wide Cab Tipper SWB 6 Sp. AMT (FEC81CR3SFAC)  
**B** 4x2 815 Wide Cab Tipper SWB 5 Sp. MAN (FEC81CR4SFAC)

## WHEEL BASE

- 2800mm  
 2800mm

## GVM (optional)

- 7,500kg (4,500kg)  
 7,500kg (4,500kg)

## GCM (optional)

- 10,000kg (8,000kg)  
 10,000kg (8,000kg)

### MASS (ESTIMATED)\*

	A	B
Front*	1670kg	1660kg
Rear*	1520kg	1520kg
Total*	3190kg	3180kg
Notes	* Mass (est.) includes oil and water but excludes spare wheel, tools & fuel. Weights provided are subject to 3.5% variation (+/-)	

### DIMENSIONS (MM)

Width Front Fender (mm)	1995
Width Rear Axle (mm)	2034
Width Frame (mm)	850
A - Length Overall (mm)	5365
C - Front Overhang (mm)	1140
D - Wheelbase (mm)	2800
G - Front Axle to Rear of Cab (mm)	525
P - Height Cab to Ground (mm)	2180
Q - Height Cab to Frame (mm)	1515
Tipper Body Width Outside	2190
Tipper Body Width Inside	2060
Tipper Body Length Inside	3150
Tipper Capacity (cubic metres)	2.4

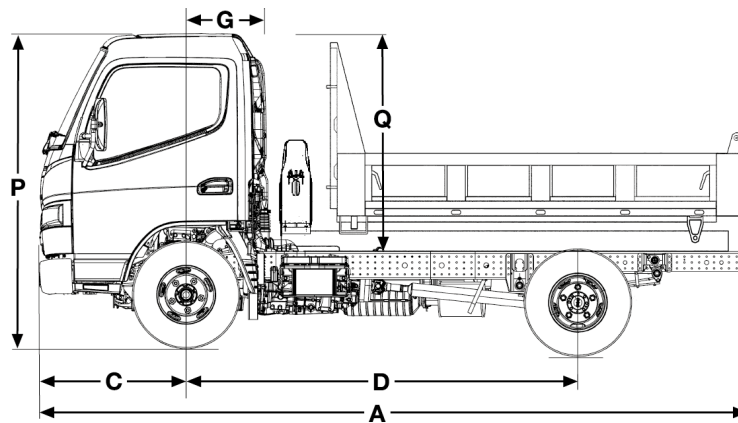

# CALL 1300 429 134

or visit [fuso.com.au](http://fuso.com.au)

# FUSO

Unless specified in writing herein the accessories, applications, bodies or equipment depicted in this document are for illustration purposes only and may not be available from Daimler Truck and Bus Australia Pacific Pty Ltd. (ABN 86 618 413 282) (DTB). No representation or warranty whatsoever is given in relation to any accessories, applications, bodies or equipment or suitability of same that are shown herein that may be manufactured, supplied or fitted by a party other than DTB. DTB reserves the right without notice or obligation to discontinue or make changes to the colour, designs, materials and specifications of the products and options referred to herein at any time. For the most current information and in order to ascertain which accessories, applications, bodies and equipment are available from DTB please contact your authorised FUSO Truck and Bus dealer. Fuso is a registered trademark of Daimler Truck and Bus Australia Pacific Pty Ltd. Copyright DTB. Reproduction in whole or part prohibited without written approval. Part Number TSC134-SSV1. Valid from 18-Jun-18.