



JAC

— THE JAC OF ALL TRADES —

7 YEAR WARRANTY
UNLIMITED. UNCOMPLICATED

ANCAP SAFETY
TESTED 2024 ★★★★★

ACTIVE SAFETY

JAC SERVE MILES & SMILES

Please note: information is accurate as of September 2024. Specification and imagery are indicative and should only be used as a guide. Vehicle and accessory specification, features, colour and trim may differ at the time of vehicle delivery.



IT'S A WHOLE LOTTA UTE

The JAC T9 is one hell of a tough Ute, built to work as hard as you do, ready to tackle any job you throw at it. Designed to perform, loaded to the hilt with extras as standard, and has an unlimited and uncomplicated 7-year warranty[^], the T9 is the JAC of all trades.

03	Introduction	13	Tradies
04	Exterior design	14	Accessories
05	Performance	15	Colours
07	Interior design	19	Specifications
10	Safety	23	Book a test drive
12	Warranty		

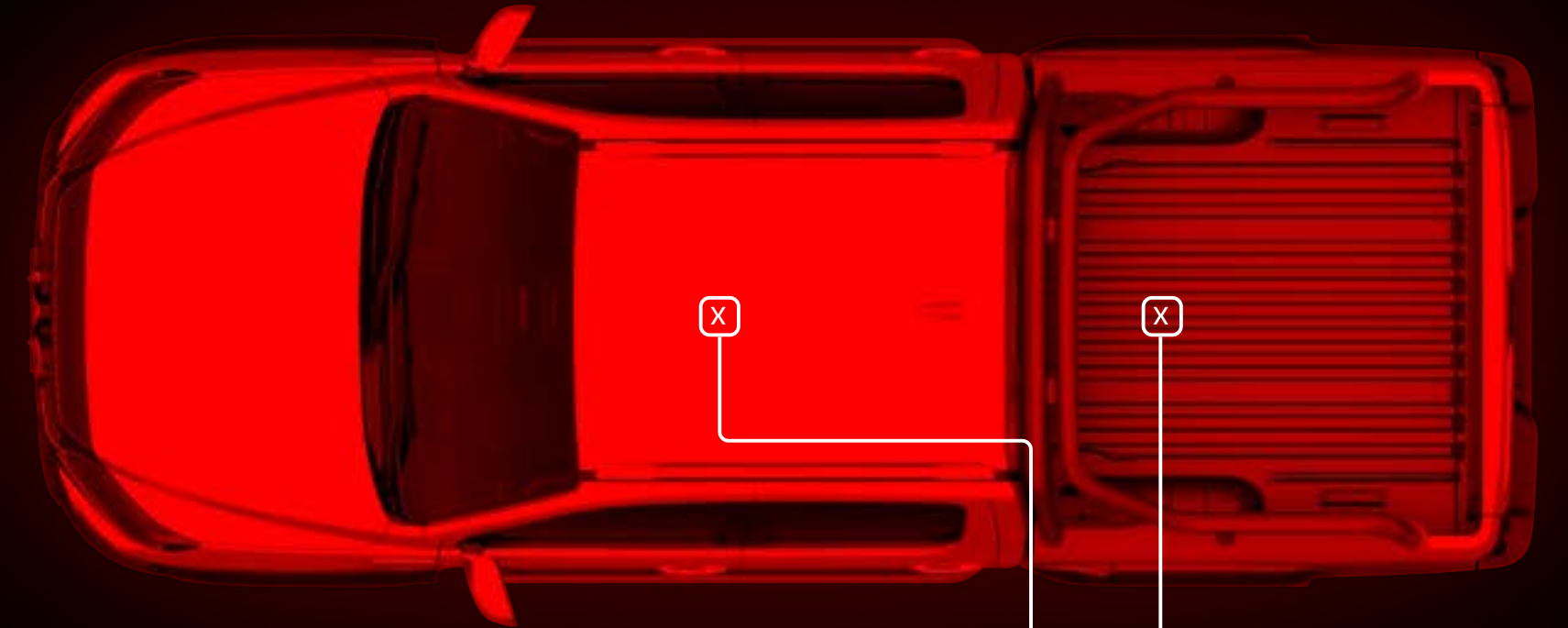

BUILT WITH GALVANISED STEEL CAB & TUB
WITH INTERNAL WAX INJECTION TECHNOLOGY

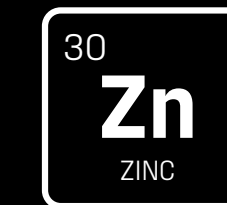

ZINC CONTENT OF 40.9%

A WHOLE LOTTA 'HARDEN THE TRUCK UP'



WHEN YOU'VE BEEN BUILDING TRUCKS SINCE 1964,
YOU GET TO KNOW A THING OR TWO ABOUT 'TOUGH'.

Put through its paces in the toughest Aussie terrain, the T9 has come up flying colours. See for yourself how the T9 took down Mount Disappointment in Victoria.

The T9 has been put together by a team of the globe's best automotive partners.



ENGINE CHAIN SYSTEM



BELT



TURBO AND TRANSFER CASE



TURBO



BEARING BUSH



TRANSMISSION

A WHOLE LOTTA RUGGED GOOD LOOKS



LED DAYTIME
RUNNING
LIGHTS (DRL)



650MM
WADING DEPTH



ROCKRAIL
SIDE STEPS



SPORTS
BAR

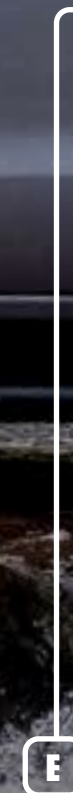

FITS A
FULL-SIZED
AUSSIE PALLET
IN THE TUB



SPRAY-ON
TUB LINER,
4 BUILT-IN CARGO
TIE-DOWN POINTS



FRONT
& REAR
PARKING
SENSORS

A WHOLE LOTTA ROUGH AND TUMBLE

CITY ROADS, BACK ROADS, GREAT OPEN ROADS AND HARDLY-THERE ROADS.

Whatever road you take, your JAC T9 is ready to rumble with 4X4 capability, and four driving modes that let you adjust to the conditions of the day. Switch to **SPORT, NORMAL, ECO** or **SNOW** in the blink of an eye.



**410Nm
TORQUE**

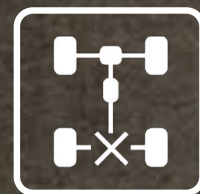

**4X4
REAR-DIFF LOCK**



**1045KG
PAYLOAD**



**3000KG TOWING
CAPACITY**



**LEAF SPRING
RIGID AXLE REAR
SUSPENSION**



**2.0L TURBO
DIESEL ENGINE**



KEY FEATURES

JAC T9 is locked and fully loaded, good to go wherever you want to go.



4X4 CAPABILITY: NORMAL, ECO, SPORT, SNOW



LEAF SPRING RIGID AXLE REAR SUSPENSION



REAR DIFF-LOCK



HILL DESCENT CONTROL & HILL-START HOLD CONTROL



650MM WADING DEPTH



1045KG PAYLOAD[~]



FUEL TANK CAPACITY 76L



FUEL CONSUMPTION COMBINED 7.6L/100KM



3000KG BRAKED TOWING



300KG TOWBALL DOWNLOAD[†]



TRAILER MODE

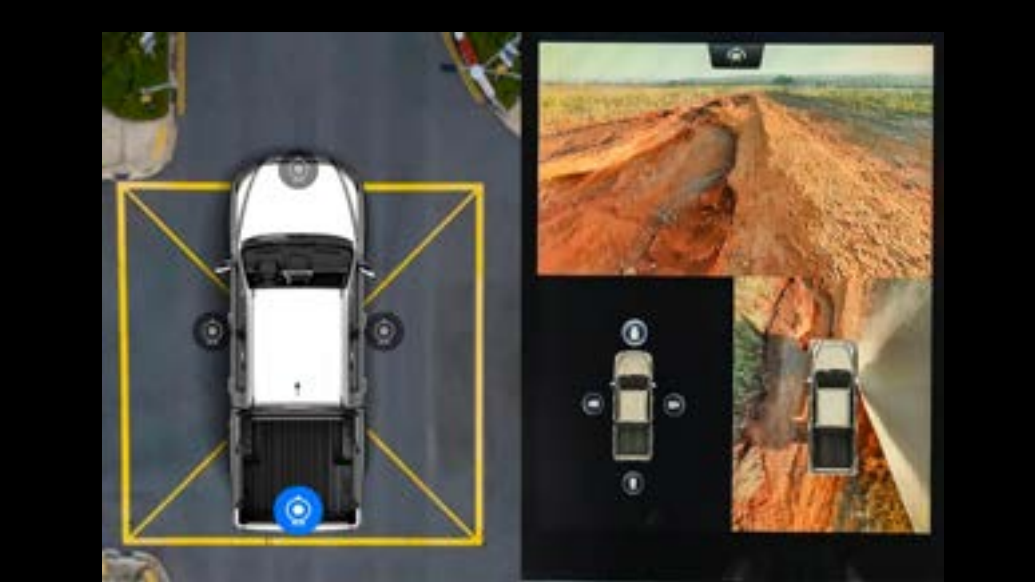

360° CAMERA[~]

A WHOLE LOTTA LUX IN THE CABIN

ALL THE EXTRA TRIMMINGS FOR THE TRADIE OFFICE.

Decked out with a lot of extra tech and extra lux, it's every bit Business Class inside your JAC T9.

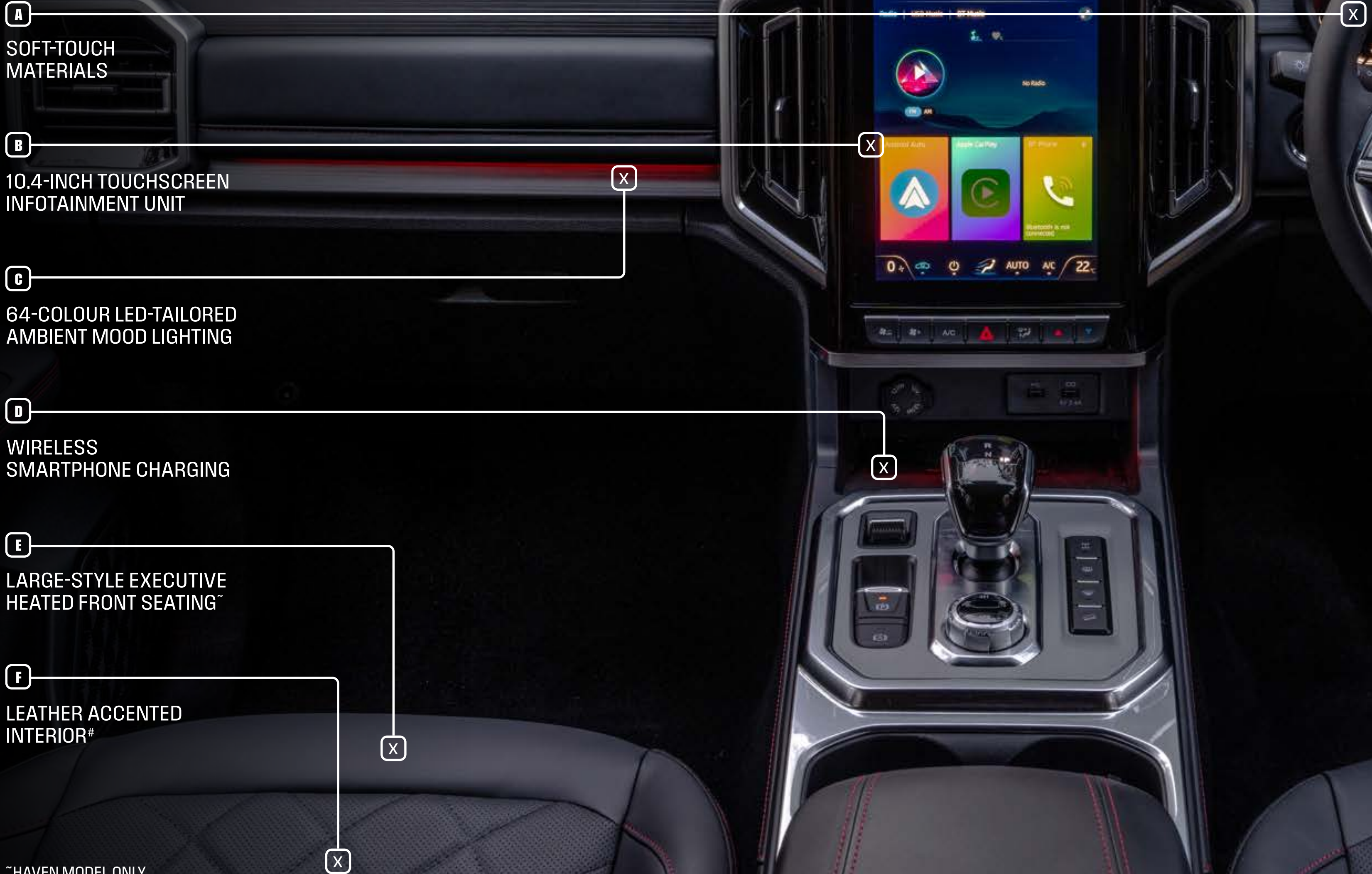

A
SOFT-TOUCH
MATERIALS

B
10.4-INCH TOUCHSCREEN
INFOTAINMENT UNIT

C
64-COLOUR LED-TAILORED
AMBIENT MOOD LIGHTING

D
WIRELESS
SMARTPHONE CHARGING

E
LARGE-STYLE EXECUTIVE
HEATED FRONT SEATING~

F
LEATHER ACCENTED
INTERIOR#

~HAVEN MODEL ONLY

KEY FEATURES

JAC T9 is locked and fully loaded, good to go wherever you want to go.



10.4 INCH INFOTAINMENT TOUCH-SCREEN WITH ANDROID AUTO™ & APPLE CARPLAY*



7 INCH COLOUR INSTRUMENT CLUSTER



WIRELESS SMART PHONE CHARGING & USB-A



360° CAMERA*



DAB+ RADIO



LEATHER ACCENTED INTERIOR



SPACIOUS BACKSEATS WITH A PERFECT 26 DEGREE RECLINE



HEATED FRONT SEATS* & CLIMATE CONTROL



220V POWER PLUG, USB-A, AND USB-C IN THE BACK



CENTRE CONSOLE COOLER BOX



64-COLOUR LED TAILORED AMBIENT MOOD LIGHTING SYSTEM



FRONT* & BACK PARKING SENSORS

A WHOLE LOTTA STREET SMARTS

YOUR JAC T9 IS TOOLED UP WITH INTELLIGENT SAFETY TECHNOLOGY.

Drive safe whatever road you take in your JAC T9. You can rely on the latest safety innovations, to help keep you out of harm's way.

ACTIVE SAFETY



KEY FEATURES

It's bumper-to-bumper safety with the ADAS (Advanced Driver Assistance System) in your JAC T9, helping to protect you at every turn. Safety all round with 7 airbags, including a front centre airbag.

ACTIVE SAFETY



TESTED 2024 ★★★★★



AUTONOMOUS EMERGENCY BRAKING (AEB)

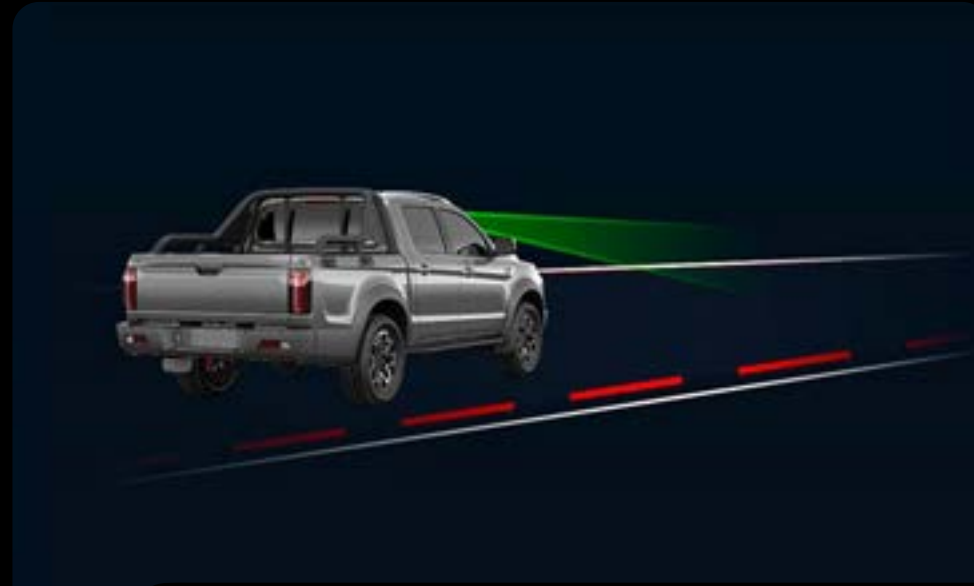

LANE DEPARTURE WARNING (LDW)



FORWARD COLLISION WARNING (FCW)



REAR COLLISION WARNING (RCW)

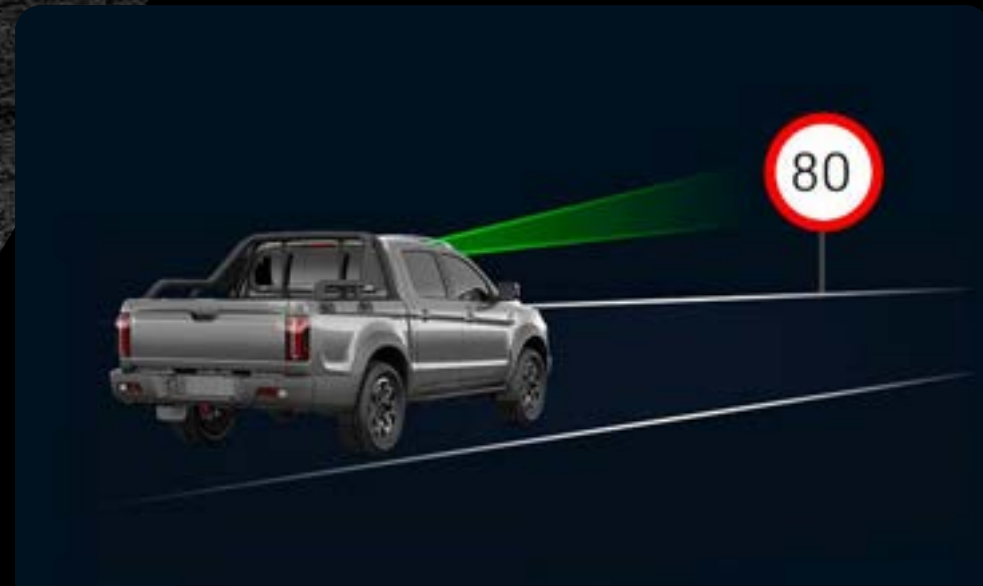

SPEED LIMIT ASSIST (SLA)



REAR AUTONOMOUS EMERGENCY BRAKING (R-AEB)



REAR CROSS TRAFFIC ALERT (RCTA)



TRAFFIC JAM ASSIST (TJA)



BLIND SPOT DETECTION (BSD)



ADAPTIVE CRUISE CONTROL (ACC)



DRIVER MONITORING SYSTEM (DMS)

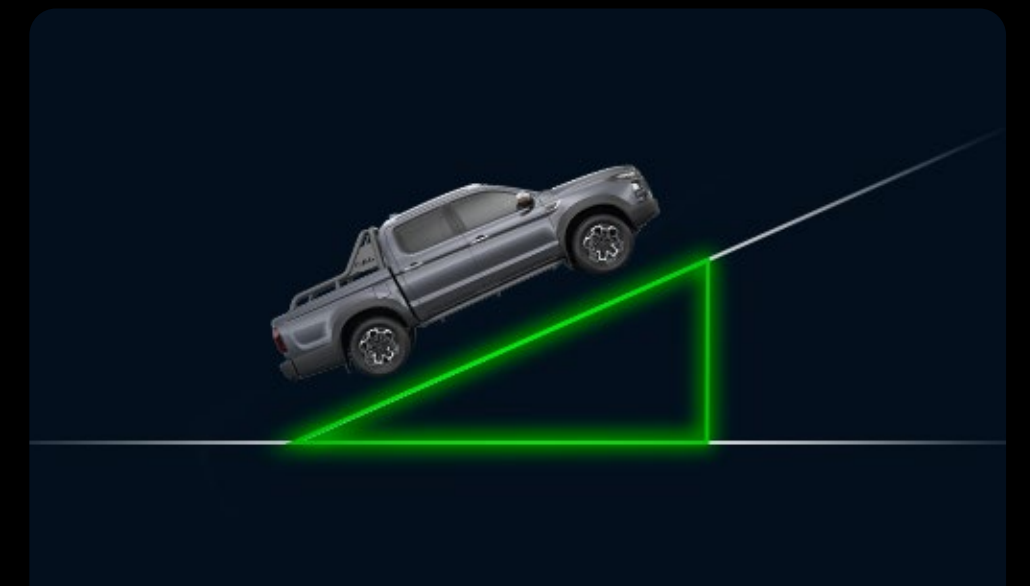

HILL-START HOLD CONTROL (HHC)

A WHOLE LOTTA 'NO WORRIES'

JAC HAS YOUR BACK ALL THE WAY.

Whether your JAC T9 is for private use, business or fleet, every JAC owner gets to drive with 'no worries'.

- 7-year warranty[^]. Unlimited KMs. Uncomplicated.
- 7-year 24/7 Roadside Assistance.
- 7-year Capped Price Servicing.
- Access to 60+ JAC Dealerships and Service Centres across Australia.
- Australia-based parts warehouse, which helps to reduce your wait time.

JAC is committed to providing comprehensive after-sales support. That's a pretty damn good handshake. It's JAC's way of making sure you and your T9 are well looked after without any unwanted surprises.



A WHOLE LOTTA ROOM UP BACK

THE TUB THAT'S A BIG TICK FOR TRADIES.

The JAC T9 can fit a full sized Aussie pallet in the tub. It comes with a spray-on protective tub liner, and 4 built-in cargo tie-down points, as standard across both models. Add to that a 1045kg payload and it makes easy work of a day on the tools.

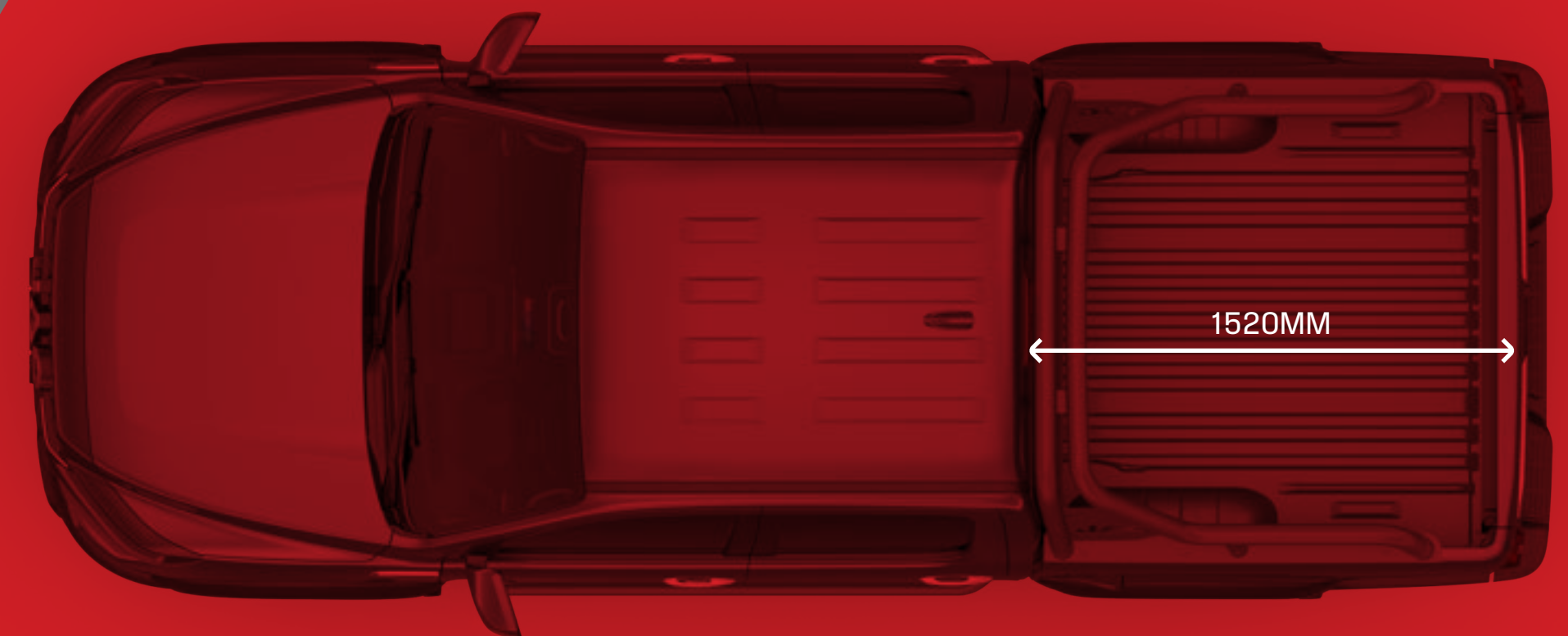
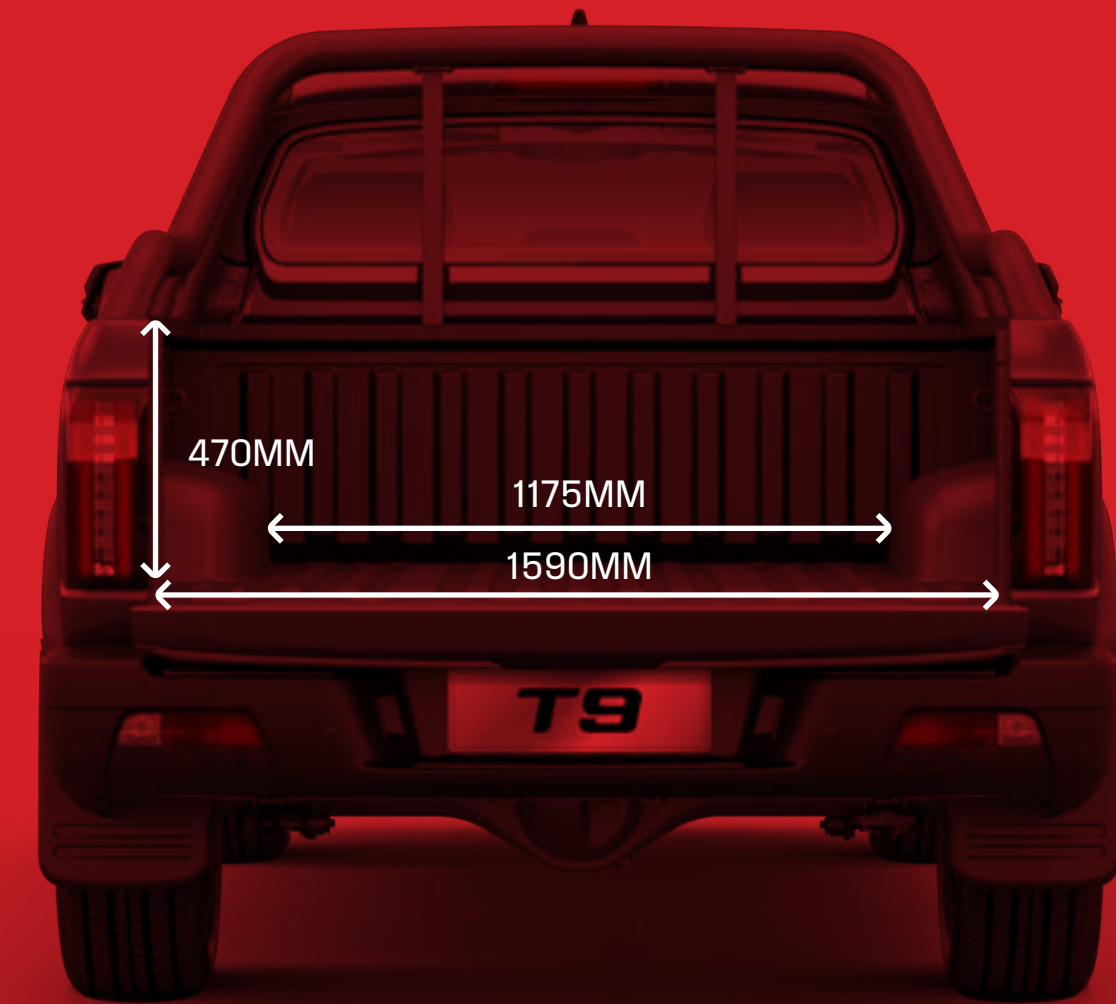

**NUDGE BAR****ROOF TRAY****LED LIGHT BAR**

A WHOLE LOTTA JACCESSORIES

**YOUR JAC T9 COMES LOADED TO THE HILT
WITH EXTRAS AS STANDARD.**

But if you want to crank your ride up a level, then you can choose from any of these genuine JAC accessories. Accessories come with a 7-year warranty[^] if fitted at time of purchase.

- + CARPET FLOOR MATS (3 PIECE)
- + DEEP DISH FLOOR MATS (3 PIECE)
- + RUBBER TUB LINER MAT
- + DEEP DISH PLASTIC TUB MAT
- + WEATHER SHIELDS
- + BONNET PROTECTOR
- + TOWBAR
- + ELECTRONIC BRAKE CONTROLLER
- + NUDGE BAR
- + OUR PRODUCT RANGE WILL CONTINUE TO GROW.
- + ROOF TRAY
- + RIDGE MOUNTS
- + LADDER RACKS
- + SOFT STYLE TONNEAU COVER
- + SOFT STYLE CANOPY
- + MANUAL ROLL TOP COVER
- + ELECTRIC ROLL TOP COVER
- + HARD CANOPY
- + LED LIGHT BAR

A WHOLE LOTTA AUSSIE INSPIRED COLOUR



KARAK



STRATUS



RED BELLY



WREN



HAMMERHEAD



HUNTSMAN



SALT BUSH







THE T9'S EXCEPTIONAL RIDE HEIGHT OFFERS SUPERIOR ROAD VISIBILITY AND SPACIOUS COMFORT FOR ALL OCCUPANTS.

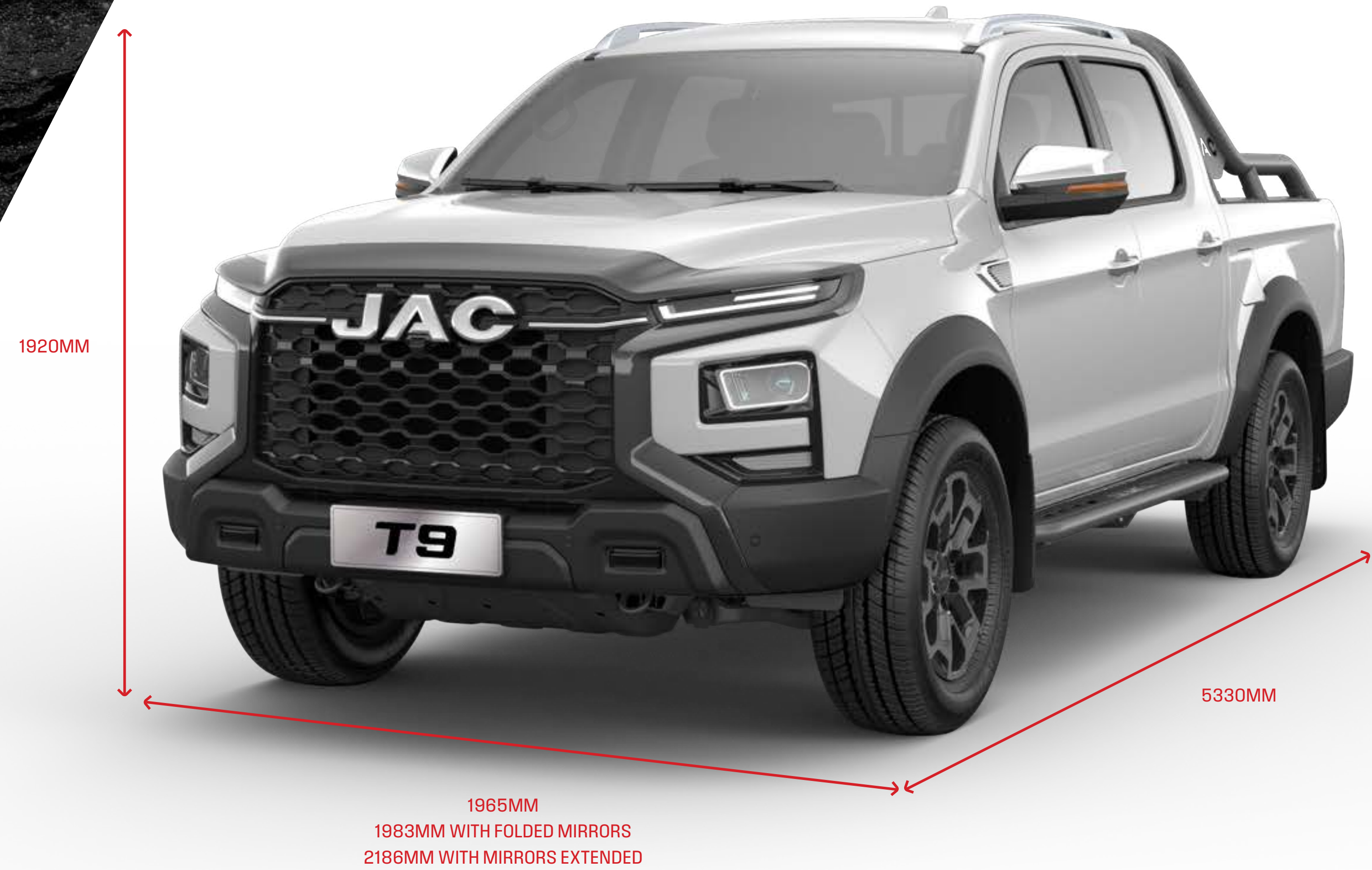

OVERALL DIMENSIONS (MM)	
Length	5330
Width	1965
Height	1920
TUB DIMENSIONS (MM)	
Length	1520
Width	1590
Height	470
GROSS COMBINATION MASS (GCM) (KG)	5430
GROSS VEHICLE MASS (GVM) (KG)	3100
KERB WEIGHT (KG)	2055
PAYLOAD (KG)	1045
TOWING CAPACTIV	
Unbraked	750
Braked	3000
Maximum Towball Download	300

WHEELBASE (MM)	3110
APPROACH ANGLE (DEGREES)	27
DEPARTURE ANGLE (DEGREES)	23
WADING DEPTH (MM)	650
GROUND CLEARANCE (MM)	210

	T9 MODEL	OASIS 4x4	HAVEN 4x4
Basic Information	Fuel Type	Diesel	Diesel
	Engine	2.0 CTI	2.0 CTI
	Product Model	JT9MY2420DDCOAPU4	JT9MY2420DDCHNPU4
	Cabin	Double-Cab	Double-Cab
Dimension	Overall Length / Width / Height (mm)	5330 / 1965 / 1920	5330 / 1965 / 1920
	Body Width With Door Mirrors Folded / Extended (mm)	1983 / 2186	1983 / 2186
	Tub Length / Width / Height (mm)	1520 / 1590 / 470	1520 / 1590 / 470
	Cargo Floor Ground Clearance (mm)	890	890
	Wheelbase (mm)	3110	3110
	Kerb Weight (kg)	2055	2055
	Gross Vehicle Mass (GVM) (kg)	3100	3100
	Payload (kg)	1045	1045
	Unbraked towing capacity (kg)	750	750
	Braked towing capacity (kg)	3000	3000
	Gross Combination Mass (GCM) (kg)	5430	5430
	Tow ball download weight (kg)	300	300
	Seating Capacity	5	5
	Min. Ground Clearance (mm)	210	210
	Maximum Wading Depth (mm)	650	650
	Track Front / Rear (mm)	1610 / 1610	1610 / 1610
	Overhang Front / Rear (mm)	945 / 1275	945 / 1275
	Min Turning Radius (m)	6.2	6.2
	Approach / Departure Angle (degrees)	27 / 23	27 / 23
Power Performance	Engine Model	HFC4DB2-2D1	HFC4DB2-2D1
	Engine Type	Common Rail+EGR+DOC+DPF	Common Rail+EGR+DOC+DPF
	Displacement (cc)	1999	1999
	Bore x Stroke (mm)	83 x 92.4	83 x 92.4
	Compression Ratio	17.5:1	17.5:1
	Net Power (kW @ rpm)	120 @ 3600	120 @ 3600
	Maximum Torque (Nm @ rpm)	410 @ 1500-2500	410 @ 1500-2500
	Emission Control	Euro V	Euro V
	Transmission	8-Speed Automatic	8-Speed Automatic
	Gear Ratio	5.000; 3.200; 2.143; 1.720; 1.314; 1.000; 0.822; 0.640; R:3.456	5.000; 3.200; 2.143; 1.720; 1.314; 1.000; 0.822; 0.640; R:3.456
	Max Speed (km/h)	150	150
	Max Gradeability (%)	30	30
	Differential Ratio (rear)	3.909	3.909
	Part-time 4WD system	•	•
	Driving Modes (Eco, Normal, Sport, Snow)	•	•
	Fuel Tank Capacity (L)	76	76
	Fuel Consumption Combined (L/100km)	7.6	7.6
	Fuel Consumption Extra Urban (L/100km)	7.1	7.1
	Fuel Consumption Urban (L/100km)	8.5	8.5
CO2 Emissions (g/km)	202	202	
Chassis & Steering	Double wishbone independent suspension with coil spring	•	•
	Non-independent leaf spring rigid axle rear suspension	•	•
	Number of leaf springs	3 + 2	3 + 2
	Rear Axle Electronic Differential Lock	•	•
	Electronic Power Steering	•	•
Wheel & Brake	Front/Rear Brake	Disc / Disc	Disc / Disc
	Electrical Park Brake with Auto Hold	•	•
	Tyre Size	265/60R18	265/60R18
	Aluminium Alloy Rim	•	•
	Full Size Spare Tyre with Steel Rim	•	•

	T9 MODEL	OASIS 4x4	HAVEN 4x4
Safety Equipment	Anti-lock Braking System (ABS)	•	•
	Electronic Brake Force Distribution (EBD)	•	•
	Brake Override System (BOS)	•	•
	Auto Hold	•	•
	Hill-Start Hold Control (HHC)	•	•
	Hill Descent Control (HDC)	•	•
	Hydraulic Brake Assist (HBA)	•	•
	Traction Control System (TCS)	•	•
	Vehicle Dynamics Control (VDC)	•	•
	Electronic Stability Control (ESC)	•	•
	Lane Departure Warning (LDW)	•	•
	Lane Keeping Assist (LKA)	•	•
	Emergency Lane Keeping (ELK)	•	•
	Blind Spot Detection (BSD)	•	•
	Lane Change Assist (LCA)	•	•
	Rear Cross Traffic Alert (RCTA)	•	•
	Forward Collision Warning (FCW)	•	•
	Rear Collision Warning (RCW)	•	•
	Door Open Warning (DOW)	•	•
	Speed Limit Assist (SLA)	•	•
	Traffic Sign Recognition (TSR)	•	•
	Traffic Jam Assistant (TJA)	•	•
	Driver Monitoring System (DMS)	•	•
	Autonomous Emergency Braking (AEB)	•	•
	Rear-Autonomous Emergency Braking (R-AEB)	•	•
	Adaptive Cruise Control (ACC)	•	•
	Integrated Cruise Assist (ICA)	•	•
	Tyre Pressure Monitoring System (TPMS)	•	•
	Driver And Front Passenger Airbags	•	•
	Front Centre Airbag	•	•
	Driver And Front Passenger Side Airbags	•	•
	Curtain Airbags	•	•
	Driver And Front Passenger Height Adjustable Seatbelt with Pre-tensioner	•	•
	3-point seatbelt for Rear Seats	•	•
	ISOFIX On Rear Outbound Seats	•	•
	Child Safety Lock	•	•
	Seatbelt Warning Buzzer	•	•
	Rear Middle Seat Headrest	•	•
Power Window Lock Driver Control	•	•	
Power Door Lock	•	•	
Speed Sensing Door Locking	•	•	
Door Ajar Warning	•	•	
Remote Central Locking	•	•	
Smart Entry and Start System	•	•	
Central Locking Rear Tailgate	•	•	
Engine Immobiliser	•	•	
Front Parking Sensors	-	•	
Rear Parking Sensors	•	•	
Reversing Camera	•	-	
360° View Camera	-	•	

	T9 MODEL	OASIS 4x4	HAVEN 4x4
Exterior Equipment	Spray On Tub Liner	•	•
	Black Iron Roll Bar	•	•
	Tub Cargo Tie Down Hooks (4)	•	•
	Roof Trim (no load-carrying capabilities)	-	•
	Privacy Glass	-	•
	Off-Road Iron Side Steps	•	•
	LED Headlamps with Daytime Running Lights	•	•
	Automatic Head Lights	•	•
	Headlamp Manual Levelling	•	•
	Follow Me Home Function	•	•
	Welcome Puddle Lamps	-	•
	Intelligent High Beam Control (IHBC)	•	•
	LED Rear Combination Lamps	•	•
	High Mounted Stop Light	•	•
	Front and Rear Fog Lamps	•	•
	Rear Step Bumper	•	•
	Body Color Door Mirrors	•	-
	Chrome Door Mirrors	-	•
	Electrically Adjustable Side Mirrors	•	•
	Heated Side Mirrors	•	•
Auto Folding Side Mirrors	-	•	
Rear Window Demisters	•	•	
Interior Equipment	Leather Accented Interior	Black	Black or Brown
	Front Reading Light	•	•
	Rear Reading Light	•	•
	Sunglasses Holder	•	•
	Driver And Front Passenger Sun Visors	•	•
	Passenger Sun Visor with Vanity Mirror	•	•
	Leather Accented Steering Wheel	•	•
	Multifunction Steering Wheel Controls	•	•
	Steering Wheel Hight Adjust	•	•
	7" Color Instrument Cluster	•	•
	Power Windows	•	•
	Remote Control Of Opening/Closing Windows	•	•
	Windows Automatic Up/Down And Anti-Clamp	•	•
	Rearview Mirror	Manual Dimming	Electrochromatic
	Rain Sensing Windscreen Wipers	•	•
	Climate Control Air Conditioning	•	•
	Rear Air Vents	•	•
	Heat Insulation Pad Under Hood	•	•
	Gas Bonnet Support	•	•
	Driver Seat Ajustment	6-Way Electric	6-Way Electric
Front Passenger Adjustment	6-Way Manual	4-Way Electric	
Heated Front Seats	-	•	
Center Console with Cooling Storage	•	•	
Rear Armrest With Cup Holders	•	•	

	T9 MODEL	OASIS 4x4	HAVEN 4x4
Multimedia Configuration	Bluetooth® Connectivity	•	•
	10.4" Touch Screen Infotainment System	•	•
	Apple CarPlay™ and Android Auto™	•	•
	Front USB Port	•	•
	Front 12V Accessory Socket	•	•
	Wireless Phone Charging With Fan Cooling Function	•	•
	Rear USB Port	•	•
	Rear 220V Power Plug	-	•
	Speakers	6	6

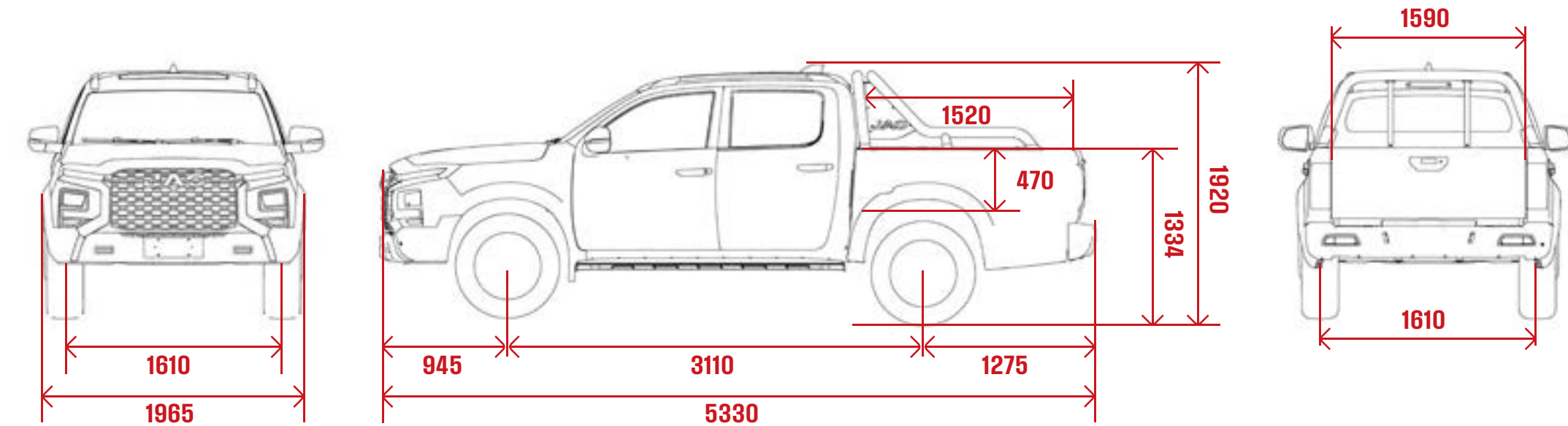



JIAC

T9

JAC

— THE JAC OF ALL TRADES —

DISCLAIMERS

[^]7-YEAR MANUFACTURER'S WARRANTY FROM THE DATE OF FIRST REGISTRATION. TERMS, CONDITIONS AND EXCLUSIONS APPLY. SEE JACUTE.COM.AU.

⁺ DRIVER ASSISTANCE SYSTEMS WORK ONLY WITHIN SYSTEM LIMITS AND ARE INTENDED TO ASSIST THE DRIVER. THE DRIVER REMAINS RESPONSIBLE FOR DRIVING THE VEHICLE AND IS REQUIRED TO REMAIN ATTENTIVE AT ALL TIMES. CHECK YOUR OWNER'S MANUAL FOR EXPLANATION OF LIMITATIONS. PLEASE DRIVE SAFELY.

CARPLAY[®] IS A TRADEMARK OF APPLE, INC. REGISTERED IN THE U.S. AND OTHER COUNTRIES.

ANDROID AUTO[™] IS A TRADEMARK OF GOOGLE LLC.

BLUETOOTH[®] IS A REGISTERED TRADEMARK OF BLUETOOTH SIG, INC.

[†]TOW BALL, TONGUE AND WIRING HARNESS SOLD SEPARATELY.

[~]PAYLOAD IS THE GVM MINUS THE KERB MASS. THE KERB MASS DOES NOT INCLUDE PASSENGERS, LUGGAGE, CARGO, ANY ACCESSORIES FITTED OR ANY TOWBALL DOWNLOAD (AS APPROPRIATE). PAYLOAD IS DISTRIBUTED ACROSS BOTH THE FRONT AND REAR AXLES; NEVER EXCEED THE GVM OR THE AXLE LIMITS.

SEE YOUR JAC MOTORS DEALERSHIP TO CONFIRM WHICH GENUINE ACCESSORY IS SUITABLE FOR YOUR VEHICLE PRIOR TO ORDERING, AS SPECIFICATIONS, APPLICABILITY, AVAILABILITY AND FITMENT REQUIREMENTS MAY CHANGE OVER TIME. CONSIDER COMBINED MASS OF LOAD AND ACCESSORIES TO ENSURE GROSS VEHICLE MASS LIMITS ARE NOT EXCEEDED.

FUEL CONSUMPTION RESULTS ACHIEVED IN ADR81/02 FUEL CONSUMPTION TESTING. RESULTS PRODUCED IN LABORATORY TEST CONDITIONS, USING SAMPLE VEHICLES WITHOUT FITMENT OF ACCESSORIES/CUSTOMISATION, AND DO NOT REFLECT REAL WORLD DRIVING. FIGURES SHOULD ONLY BE USED FOR COMPARATIVE PURPOSES.

[#]LEATHER ACCENTED FEATURES AND UPHOLSTERY MAY CONTAIN SYNTHETIC MATERIAL.

IMPORTANT NOTICE - JAC AUTO (PICKUP) ENSURES THE MATERIAL IS ACCURATE AT THE TIME OF PUBLISHING. ALL INFORMATION MUST BE CONFIRMED WITH YOUR JAC MOTORS DEALER AT THE TIME OF ORDERING, AS SPECIFICATIONS, APPLICABILITY AND AVAILABILITY MAY CHANGE OVER TIME.

JAC AUTO (PICKUP) RESERVES THE RIGHT TO CHANGE AND/OR DISCONTINUE, WITHOUT NOTICE, MODELS, PRICES, COLOURS, MATERIALS, EQUIPMENT, SPECIFICATIONS TO THE EXTENT PERMITTED BY LAW, JAC AUTO (PICKUP) WILL NOT BE LIABLE FOR ANY DAMAGE OR LOSS INCURRED FROM RELYING ON THE INFORMATION AND IMAGES CONTAINED IN THIS MATERIAL.