

ISUZU  
**D-MAX**



**DEPEND ON IT**

# DESIGNED FROM HISTORY



4x4 LS-U Crew Cab Ute in Ash Beige metallic



1963 The Isuzu Wasp is released as the 1st ute in Isuzu's history



1972 The Isuzu Faster is released and is exported all around the world



1980 Isuzu 'pick-up' or 'KB' is offered in three cab styles: single, spce and crew cab



1988 A monumental feat saw the Isuzu ute become the widest body in its class



2002 The internationally branded Isuzu D-MAX ute is launched worldwide



2010 D-MAX impresses with its tough, stylish and fuel efficient model line-up

Founded in 1916, Isuzu Motors has the longest history of any Japanese vehicle manufacturer and is one of the world's largest producers of commercial vehicles spanning light, medium and heavy weight classes. Isuzu Motors is also the world's largest commercial diesel engine manufacturer, producing over 22 million engines to date. Isuzu diesel engines are relied upon by top-level automobile manufacturers around the world for their superior performance and exceptional fuel economy.

The origin of Isuzu's D-MAX ute can be traced back to the Isuzu WASP in 1963, which was produced under the initiative to build a car that looked like a passenger vehicle but functioned as a truck. Over the next 40 years, backed by record sales, Isuzu utes were exported to North America, South Africa, Australia and other markets around the world, where to this day, over two million people depend on the strength, reliability and economy of Isuzu utes.

**Fuel Consumption Figures**

Isuzu D-MAX Models	Transmission	Combined Fuel Consumption <sup>A</sup>
4x2 SX Single Cab Chassis Low-Ride	Manual	8.2L/100km
4x2 SX Single Cab Chassis High-Ride	Automatic	8.3L/100km
4x2 SX Crew Cab Ute Low-Ride	Manual	8.3L/100km
4x2 SX Crew Cab Ute High-Ride	Automatic	8.3L/100km
4x2 LS-U Crew Cab Ute High-Ride	Manual	8.5L/100km
4x2 LS-U Crew Cab Ute High-Ride	Automatic	8.6L/100km
4x4 Single, Space and Crew Cab models	Manual	8.5L/100km
4x4 Single, Space and Crew Cab models	Automatic	8.6L/100km



Improved redesign of fuel injector pintle caps for optimum fuel efficiency



State-of-the-art aerodynamic exterior design, tested for minimal drag



Multi Information Display of instant and average fuel consumption



Fuel efficient sequential shift 5-speed automatic transmission



4x4 LS-M Crew Cab Ute in Titanium Silver metallic

# DEPEND ON IT FOR FUEL ECONOMY

The "pursuit of people's trust" underlies product development at Isuzu. As a matter of principle, the vehicles we manufacture must be worthy of the trust of our customers and stakeholders. This philosophy guides us in perfecting our technology, and creating vehicles with a conscience.

To reduce the environmental impact of vehicles, Isuzu is fully committed to lowering emissions over the course of a vehicle's life cycle - from materials procurement to disposal and recycling. This philosophy is no better illustrated than in our Isuzu D-MAX.

Sporting sleek exterior styling, the Isuzu D-MAX has further improved on its renowned fuel efficiency and performance after extensive wind tunnel testing at the Japan Railway Technical Research Institute where the Bullet train is developed. Advanced refinement in the wind tunnel of

Italian auto design house Pininfarina has ensured the Isuzu D-MAX is the most aerodynamic yet with record low Cd (drag coefficient) figures. This development has also realised an improvement in cabin noise levels adding to passenger comfort.

<sup>A</sup>Tested to ADR 81/02, the Australian government's standard lab based test. Your fuel figures depend on driving style, conditions of usage, vehicle condition and load, and other factors.

4x4 LS-U Crew Cab Ute in Cosmic Black mica

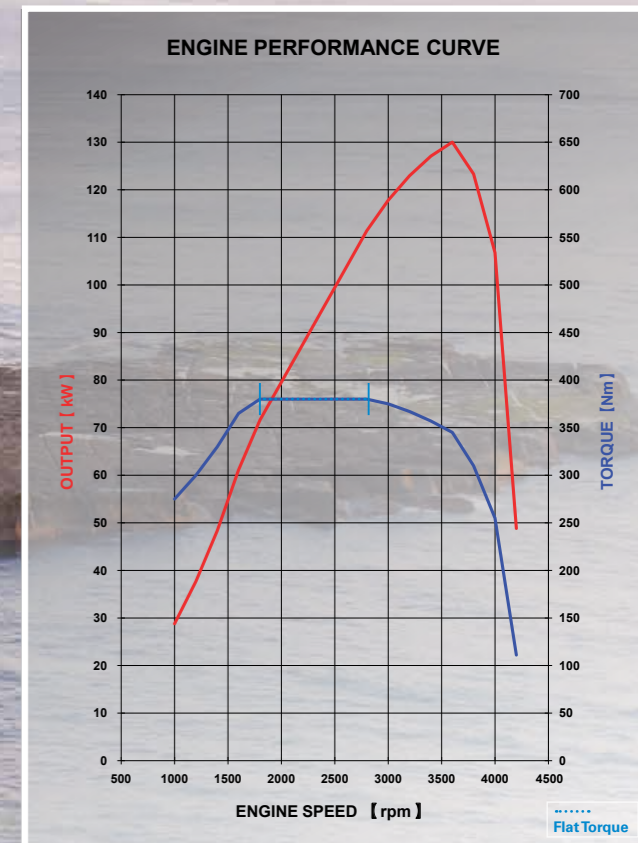

Isuzu 4JJ1-TC Hi-Power turbo diesel engine offers maximum torque output across a wide rev range minimising the need to change gears

# DEPEND ON IT FOR PERFORMANCE

The Isuzu D-MAX range is powered by a highly refined 3-litre turbo diesel common rail engine which offers superior fuel efficiency thanks to low friction, fuel injection optimisation and a large front-mounted intercooler.

This advanced Euro4-compliant unit generates 130kW of power and a peak torque output of 380Nm at a low 1800rpm. The torque is delivered across a flat curve through a large majority of the rev-range to aid drivability and make towing up to 3.5 tonne\* a breeze.

\*Braked towing on 4x4 models.

Mated to an advanced five-speed 'Rev-Tronic' automatic transmission with sequential sports mode, the auto box is electronically controlled by the transmission control module (TCM) and features an adaptive-learning function which constantly monitors brake and throttle applications. This allows the transmission to automatically select the most appropriate shift points and lock-up points

depending on the driver's behaviour, the vehicle speed and the vehicle load. A smooth shift manual transmission is also available. It features a superior gear-lever pivot point, reducing gear-shift travel for a sportier feel.

# SPIRIT OF TRUCK

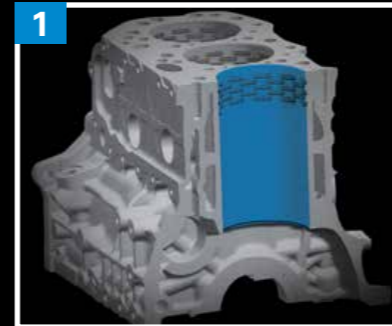
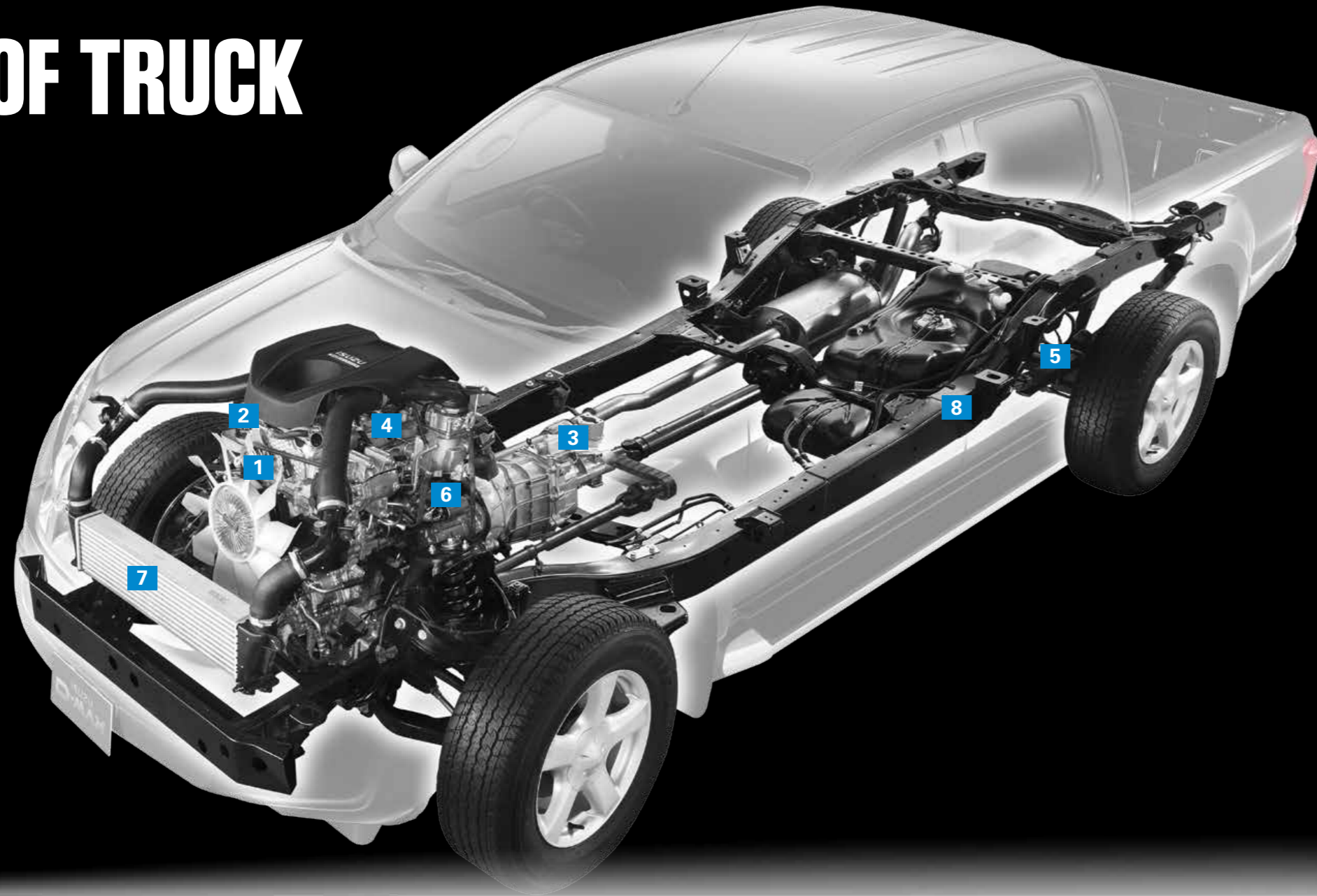

1 Advanced induction hardened liner technology eliminates the need for cylinder liners

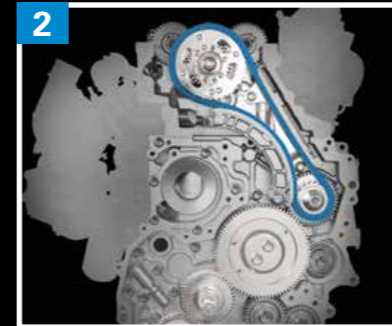

2 Steel timing chain (not poly belt)



3 Optimised automatic and manual transmissions with equal maximum torque output



4 Sophisticated engine head; cam-to-valve roller bearings and variable swirl action gas flow

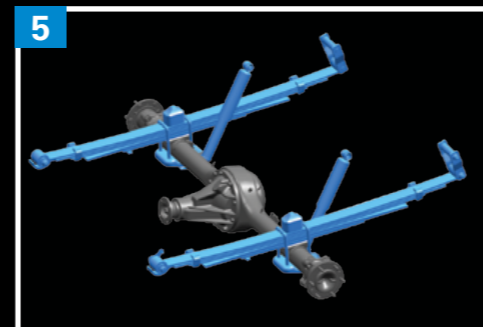

5 Independent double wishbone and gas shock absorber front suspension. Over slung rear springs for improved off-road operation\*

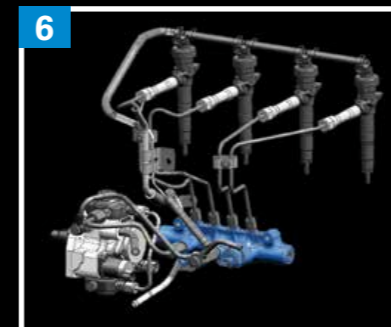

6 High pressure common rail fuel injection system minimises the amount of fuel needed in the combustion process, providing superior fuel economy

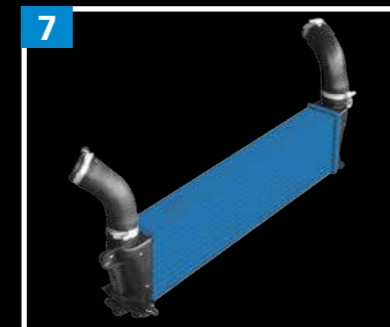

7 A large intercooler means greater thermo-cooling capacity

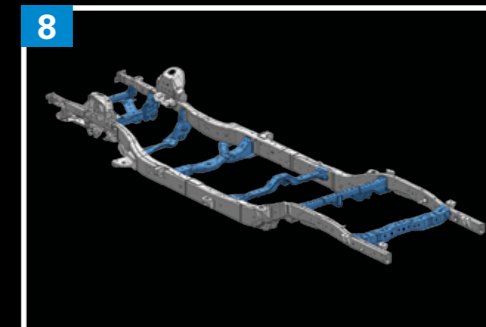

8 A strong, durable yet light chassis design

The Isuzu D-MAX comes from a lineage of the world's toughest, most reliable workhorses. Almost a century of truck-manufacturing DNA has gone into the Isuzu D-MAX and it remains the only ute produced by a commercial vehicle manufacturer. Featuring a truck-tough chassis means better balance and performance whether loaded or not, delivering superior stability and roadholding in all conditions.

As a testament to the immense confidence we have in building durable, reliable and efficient utes, every Isuzu D-MAX is backed by a five-year warranty and five-year Premium Roadside Assist package<sup>^</sup> – which adds further peace of mind when it comes to protecting your investment.

Designed with superior know-how combined with state-of-the-art Japanese technology, you don't just get a ute, you get true 'Spirit of Truck' with every Isuzu D-MAX.

<sup>^</sup>5yr/130,000km whichever occurs first, for eligible customers; excludes accessories and trays.  
\*Available only on 4x2 High-Ride and all 4x4 models.





Electroluminescent instrument display gives clear vision to the driver



All SX and LS are equipped with steering wheel cruise and audio controls



Remote keyless entry



Glove compartment (lower) and article storage compartment (upper) with easy access power outlet



Dual function storage compartment and cupholder

# DEPEND ON IT FOR CONVENIENCE

At your finger tips you will find all the technology and modern conveniences you have come to expect in a new ute. From the entry-level Isuzu D-MAX 4x4 EX Single Cab Chassis through to the top-of-the-range 4x4 LS-U Crew Cab Ute, the Isuzu D-MAX offers a generous complement of standard equipment, including cruise control and Multi-Information Display (MID), air conditioning with a fine-particle pollen filter and an audio system with mini-USB input, iPod® and Bluetooth®

connectivity for phone/audio streaming<sup>1</sup>. SX and LS models also feature Isuzu's 'Sky Sound' roof-mounted surround sound system<sup>1</sup> and a leather steering wheel featuring cruise and audio controls. Remote keyless entry, power windows and mirrors are standard on SX & LS Models. You will also discover a host of convenient storage compartments and cup holders.

<sup>1</sup>The Bluetooth® word mark is owned by Bluetooth SIG, Inc. Not all devices will be compatible and functionality will vary depending on the device.

<sup>2</sup>Not available on single cab models.

iPod® is a trademark of Apple, Inc.

LS-U Crew Cab interior with automatic transmission

LS-U Crew Cab interior with manual transmission

# DEPEND ON IT FOR SAFETY AND COMFORT

The entire D-MAX range comes standard with a host of important safety benefits, including six airbags (dual front, curtain and side), Electronic Stability Control (ESC), Traction Control System (TCS) and 4-channel 4-sensor ABS (Anti-skid Brake System) with EBD (Electronic Brakeforce Distribution) and Brake Assist (BA). A high-strength tailor blank welded passenger safety cell with side impact anti-intrusion bars also increases occupant safety.

Further enhancing driver safety is a collapsible steering column and brake pedal, while pedestrian safety has been improved with an impact absorbing bonnet design, recessed fog lamps and shatter-resistant polycarbonate headlamp covers. Rear LED brake lights are also standard on the Isuzu D-MAX LS models, as are projector lens headlights. All this adds up to give the Isuzu D-MAX a five-star ANCAP safety rating\* to keep you safe whether you're hard at work or on an adventure.

A larger cabin interior across the range provides greater head and leg room for all passengers, and a contoured seat design with 'wrap-around' bolsters provide increased shoulder, back and base support delivering more comfort for occupants. Thoughtfully-designed wider door arches and A-pillar assist grips allows for easy access to the cabin.

\*On 4x4 crew cab models.



For added safety and protection – six airbags: dual front, curtain and side

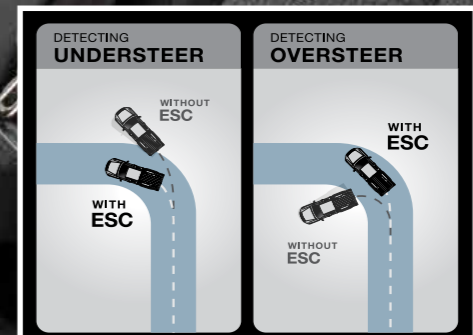

Included on all D-MAX models, Electronic Stability Control (ESC) detects if the vehicle is under or oversteering

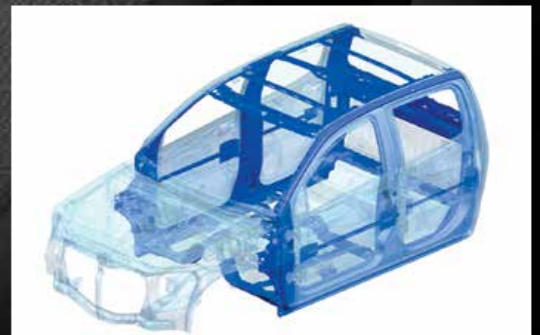

The cabin is constructed from high tensile tailor blank welded steel for unyielding strength and rigidity of the passenger safety cell





4x4 SX Crew Cab Chassis in Titanium Silver metallic with Heavy Duty Steel Tray

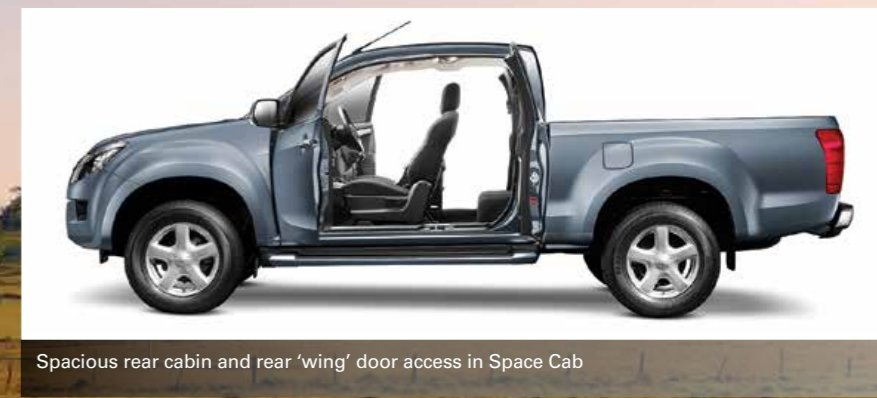

Spacious rear cabin and rear 'wing' door access in Space Cab



SX interior with 'Sky Sound' 6 speaker audio system<sup>1</sup> and Bluetooth<sup>®</sup> audio streaming<sup>1</sup>



Fold down rear seats in Space Cab with storage compartments

# DEPEND ON IT TO GET THE JOB DONE

Like Isuzu trucks, the Isuzu D-MAX is built to work hard for all professionals - whether you're working the land, a building site or keeping the family on the go. Featuring a superior designed ladder chassis that provides a robust platform for all D-MAX variants. Dubbed the "i-GRIP" (Isuzu Gravity Response Intelligent Platform), this proven chassis has increased strength and rigidity by 42%

over its predecessor, thanks to a larger side rail cross-section and the addition of 'cross member to chassis rail' braces. With improved stability while both loaded and towing, it ensures long term durability when exposed to harsh driving environments and enables 4x4 models a 3.5-tonne braked towing capacity.

Our ingenious 'Space Cab' is a worker's best mate – it features convenient rear 'wing' doors to make cabin access even easier and pull-down 'jump' seats for additional passengers. For even more versatility, match your D-MAX with a genuine Isuzu D-MAX tray body. Choose from our range of alloy or steel bodies and accessories so your equipped to get the job done.

To top it off, all SX and LS-M models come standard with tough 'All-terrain' tyres, which make light work of even the roughest of terrain but also offer a smooth ride on-road with low road noise.

<sup>1</sup>The Bluetooth<sup>®</sup> word mark is owned by Bluetooth SIG, Inc. Not all devices will be compatible and functionality will vary depending on the device.  
<sup>2</sup>Not available on single cab models.





"Terrain Command" 4WD system allows for simple shift from 2WD high, 4WD high and 4WD low



Large front brakes with ventilated disc

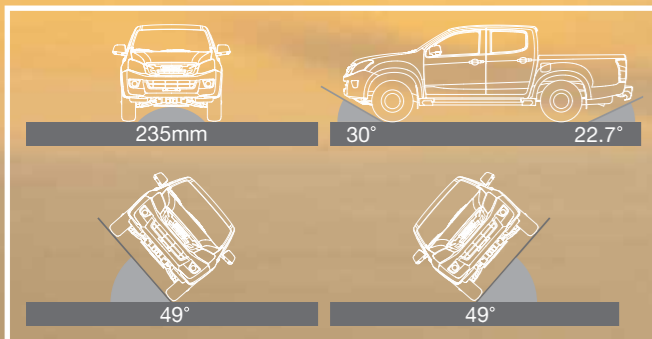

Angle dimensions of the LS-U model only



Steel underbody guards on sump and transfer case on 4x4 models



4x4 LS-M Crew Cab Ute in Titanium Silver metallic

# DEPEND ON IT FOR ADVENTURE

The Isuzu D-MAX will redefine your spirit for adventure and allow you to go places you've never before dared. Independent double wish-bone with coil springs and gas shock absorbers guarantee superior front end grip and steering control, while the rear suspension consists of long span leaf-springs (under-slung on low-ride models and over-slung on high-ride models) resulting in excellent power down and stability under every road condition with or without loading.

The Isuzu D-MAX also features a "Terrain Command" 4WD select dial, allowing the driver to adjust between 2WD-high and 4WD-high modes while travelling at speeds of up to 100km/h, and 4WD-low for rugged terrain. The automatic transmission also engages 'Hill-Descent' and 'Hill-Ascent' for when the going gets tough, and steel underbody protection along with generous ground clearance adds further piece of mind when pushing the limits off-road.



# TRIED AND TESTED

4x4 SX Crew Cab Ute in Mineral Grey metallic

Over 4,000,000km of strenuous testing in searing heat, heaving rain, hail and even snow was conducted in the development of the latest Isuzu D-MAX to ensure it never lets you down. We've called on our truck engineering heritage to bring you a tough reliable partner and refined it with all the comforts, technology and safety features you've come to expect from a passenger car.

Powered by our most responsive engine ever – the Isuzu D-MAX strives ahead of the competition with its legendary durability and fuel efficiency. Whether it's hauling big loads, powering through the work week, cruising through the weekend or going where the others won't, the Isuzu D-MAX is simply better – Depend on it!



**ISUZU**  
**UTE**  
Spirit of Truck

[www.isuzuute.com.au](http://www.isuzuute.com.au) Toll Free: 1300 147 898

This brochure should be read with the separate Isuzu D-MAX Specification insert. Isuzu UTE Australia Pty Ltd (ABN 80 129 563 739, 1000 Wynnum Road, Cannon Hill, Queensland, 4170, Australia) reserves the right to change specifications and content without notice, subject to any applicable Federal, State or Territory laws or regulations which may apply. Any accessories shown herein are illustrative and generally are extra-cost optional, not standard equipment. Colours depicted herein may differ from actual due to the printing process. Please refer to [isuzuute.com.au](http://isuzuute.com.au) or consult your authorised Isuzu UTE Dealer for current availability of models, options, specifications, colours and Isuzu UTE Genuine Accessories. No part of this brochure can be reproduced without the written permission from Isuzu UTE Australia. All information is true and correct at the time of publishing, July 2014. Printed in Australia. Copyright Isuzu UTE Australia Pty Ltd 2014. Part No.: 5443756110 - 2015MY D-MAX SALES BROCHURE

  
FSC  
[www.fsc.org](http://www.fsc.org)  
MIX  
Paper from  
responsible sources  
FSC® C001959

Engine			
Series	Isuzu 4JJ1-TC Hi-Power		
Description	3.0 litre turbo diesel, in-line 4-cylinder, DOHC, 16-valve		
Maximum torque	380 Nm @ 1800→2800 rpm (automatic & manual)		
Maximum power	130 kW @ 3600 rpm		
Bore x stroke	95.4mm x 104.9mm		
Displacement	2999cc		
Compression ratio	17.3 : 1		
Cylinder head	Isuzu-patent special aluminium alloy with double-walled water jacketing		
Valve gear	Chain-driven dual overhead camshafts, roller rockers, 4 valves/cylinder		
Induction	Electronic high pressure common rail direct fuel injection with VSS (Variable Swirl System) and intercooled VGS (Variable Geometry System) turbo charger		
Cylinder block	Cast iron upper with induction-hardened cylinder bores, cast alloy lower; special pistons with nickel composite oil rings		
Emission level	Euro 4		
Alternator	90 amp		
Transmissions			
Manual	Isuzu MUX 5-speed manual with high torque capacity and output reduction 275mm diameter clutch plate		
Automatic	Aisin AW TB50-LS 5-speed with sequential shift and brake shift lock electronically controlled, tri-mode with Adaptive Grade Logic Control and fuel-saving lock-up torque converter on gears 3, 4 & 5 ▶ Adaptive Grade Logic Control: holds gear in varied-gradient ascents, selects gear on steep descents to hold speed with engine braking ▶ Hill-ascent and hill-descent control		
Ratios: 1		<b>5-speed Manual</b>	<b>5-speed Automatic</b>
	1st	4.332	3.520
	2nd	2.561	2.042
	3rd	1.492	1.400
	4th	1.000	1.000
	5th	0.791	0.716
	Reverse	3.947	3.224
Final drive	4x2 SX	3.416	3.727
	LS	3.727	3.727
	4x4	3.727	3.727
	Snorkelled diff breathers to reduce mud blockage		
Transfer gearing	4x4 low-range	2.482	2.482
	4x4 high-range	1.000	1.000
4x4 system	"Terrain Command" control with 'shift on the fly' 2-high↔4-high selection at up to 100km/h		
Drivetrain system	TCS (Traction Control System) & ESC (Electronic Stability Control) on all model variants		

Chassis	
Frame	Separate, full-length heavy-duty truck chassis with 7 cross members on low ride models & 6 cross members on high ride models
Front suspension	4x2 SX Low-Ride model: Independent, coil springs, gas shock absorbers, upper and lower wishbones, stabiliser bar 4x2 High-Ride & 4x4 models: Independent, high-ride, coil springs, gas shock absorbers, upper and lower wishbones, stabiliser bar
Rear suspension	4x2 SX Low-Ride model: Alloy-steel underslung semi-elliptic leaf springs, heavy-duty on cab chassis; gas shock absorbers 4x2 SX High-Ride & 4x4 models: Alloy-steel overslung long-span semi-elliptic leaf springs, heavy-duty on cab chassis and LS-M; gas shock absorbers
Axles	
Front	Independent 4x4: fully floating with outer CV, inner double offset joints and equal length driveshafts. Ratings: Low-Ride 1250kg; High-Ride 1350kg
Rear	Rigid semi-floating banjo with hypoid final drive and dual tapered needle roller bearings. Rating: 1870kg
Steering	
Engine-speed-sensitive variable capacity power-assisted rack and pinion system; 3.2 turns lock-to-lock via tilt-adjustable steering wheel	
Brakes	
Power-assisted via 10.5" servo unit; 300mm diameter ventilated front discs with 2-piston callipers, 295mm rear drums (280mm on Low-Ride models)	
Anti-lock Brake System (ABS) with Electronic Brakeforce Distribution (EBD) and Emergency Brake Assist (EBA)	
Central pull up park brake	
Wheels & Tyres	
4x2 SX (Low-Ride)	15" x 6.5" drilled silver-finish steel; 215 / 70 R15c Highway Terrain
4x2 SX (High-Ride)	16" x 7" drilled silver-finish steel; 245 / 70 R16 All Terrain
4x2 LS-U (High-Ride)	17" x 7" alloy; 255 / 65 R17 Highway Terrain
4x4 EX, SX	16" x 7" drilled silver-finish steel; 245 / 70 R16 All Terrain
4x4 LS-M	16" x 7" alloy; 245 / 70 R16 All Terrain
4x4 LS-U	17" x 7" alloy; 255 / 65 R17 Highway Terrain
All models: full size steel spare wheel	
Warranty & Roadside Assistance	
New vehicle warranty and premium roadside assistance for 5 years/130,000km, whichever occurs first, for eligible customers; excludes accessories and trays.	
Please read with current vehicle brochure. Isuzu UTE Australia reserves the right to change specifications and features at any time.	

Published July 2014.

Colours depicted herein may differ from actual due to the printing process. Please refer to [isuzuute.com.au](http://isuzuute.com.au) or consult your authorised Isuzu UTE Dealer for current availability of models, options, specifications, colours and Isuzu UTE Genuine Accessories.



# FEATURES & SPECIFICATIONS

FEATURES														
	SX	SX	SX	SX	LS-U	EX	SX	SX	LS-U	SX	SX	LS-M	LS-U	
<b>Engine</b>														
2999cc DOHC 4cyl. with intercooled turbo charger, Euro 4 (380Nm, 130kW)	●	●	●	●	●	●	●	●	●	●	●	●	●	●
<b>Transmissions</b>														
5-speed manual transmission	●		●		●	●	●	●	●	●	●	●	●	●
5-speed "Rev-Tronic" automatic transmission with sequential sport mode		●		●	●	●	●	●	●	●	●	●	●	●
<b>Safety &amp; Security</b>														
4-channel 4-sensor ABS (Anti-lock Brake System) with EBD (Electronic Brakeforce Distribution)	●	●	●	●	●	●	●	●	●	●	●	●	●	●
Electronic Stability Control (ESC)	●	●	●	●	●	●	●	●	●	●	●	●	●	●
Traction Control System (TCS)	●	●	●	●	●	●	●	●	●	●	●	●	●	●
Emergency Brake Assist (EBA)	●	●	●	●	●	●	●	●	●	●	●	●	●	●
6 Airbags: dual front, curtain and side airbags	●	●	●	●	●	●	●	●	●	●	●	●	●	●
Height-adjustable upper mounts for front seat belts	●	●	●	●	●	●	●	●	●	●	●	●	●	●
Pre-tensioners with load limiters for front seat belts (*Dual Pretensioners)	●	●	●	●	●	●	●	●	●	●*	●*	●*	●*	●*
3-point retractable seat belts for all rear and centre seating positions (*centre seat not applicable)			●	●	●				●*	●*	●	●	●	●
Childseat tethers x 3 (rear - outer and centre)			●	●	●				●	●	●	●	●	●
Height-adjustable head restraints for all full-size seats	●	●	●	●	●	●	●	●	●	●	●	●	●	●
Child-proof rear door locks			●	●	●				●	●	●	●	●	●
Single 10.5 inch servo brake master cylinder	●	●	●	●	●	●	●	●	●	●	●	●	●	●
Side anti-intrusion bars inside all doors	●	●	●	●	●	●	●	●	●	●	●	●	●	●
Engine immobilizer	●	●	●	●	●	●	●	●	●	●	●	●	●	●
Warning alarm: headlights or parking lights on with ignition key removed	●	●	●	●	●	●	●	●	●	●	●	●	●	●
Rear window demister			●	●	●				●	●	●	●	●	●
High Density Polyethylene (HDPE) fuel tank	●	●	●	●	●	●	●	●	●	●	●	●	●	●
High mount brake light on cabin	●	●	●	●	●	●	●	●	●	●	●	●	●	●
Dual horn	●	●	●	●	●	●	●	●	●	●	●	●	●	●
<b>Protection</b>														
Under-front steel plate skid/splash shield (high-ride)		●		●	●	●	●	●	●	●	●	●	●	●
Under-front aero cover (low-ride)	●		●											
Steel plate guards: sump, transfer case, fuel tank leading edge; sheet steel under fuel tank			●			●	●	●	●	●	●	●	●	●
<b>Suspension and Brakes</b>														
Standard rear leaf suspension			●	●	●				●		●		●	
Heavy duty rear leaf suspension	●	●				●	●	●		●		●		●
Front independent, coil spring suspension w/gas shock absorbers, upper and lower wishbones & stabiliser bar	●	●	●	●	●	●	●	●	●	●	●	●	●	●
Heavy-duty brakes: 300mm ventilated front discs w/twin-pot calipers, 295mm rear drums			●	●	●	●	●	●	●	●	●	●	●	●
Heavy-duty brakes: 280mm ventilated front discs w/twin-pot calipers, 295mm rear drums	●		●											
<b>Seating</b>														
Front bucket whiplash protection seats	●	●	●	●	●	●	●	●	●	●	●	●	●	●
Height-adjustable driver's seat					●				●	●	●	●	●	●
Split-fold rear seat (*with centre arm rest)			●	●	●*					●*	●*	●*	●*	●*
Rear twin pull-down jump seats									●	●				
Rear centre seat headrest			●	●	●					●	●	●	●	●
<b>In-cabin Storage</b>														
Upper and lower glovebox compartments	●	●	●	●	●	●	●	●	●	●	●	●	●	●
Power outlet in glovebox	●	●	●	●	●	●	●	●	●	●	●	●	●	●
Centre floor console with rear flipout cup holder (*AT models only)				●	●					●*	●*	●	●	●
Dual-purpose driver and front passenger cup holder tray	●	●	●	●	●		●	●	●	●	●	●	●	●
Rear passenger door cup holders			●	●	●					●	●	●	●	●
Map pockets on backs of front seats					●				●	●	●	●	●	●
Overhead console with twin map lights & flip-down sunglasses case					●				●			●	●	●
Front door storage compartment with bottle bulge	●	●	●	●	●	●	●	●	●	●	●	●	●	●
Two coat hooks			●	●	●				●	●	●	●	●	●
Tool storage under rear flip-up seats			●	●	●				●	●	●	●	●	●



# FEATURES & SPECIFICATIONS

FEATURES	Chassis Options													
	SX	SX	SX	SX	LS-U	EX	SX	SX	LS-U	SX	SX	LS-M	LS-U	
<b>Rear Tub</b>														
Double-walled ute tub			•	•	•				•		•	•	•	•
4 cargo tie-down hooks inside ute tub			•	•	•				•		•	•	•	•
Cab guard frame (unboltable for canopy and tonneau cover fitting)			•	•							•			
<b>Exterior Style</b>														
Short front overhang for optimal manoeuvrability & approach angle	•	•	•	•	•	•	•	•	•	•	•	•	•	•
Halogen multi-reflector headlights	•	•	•	•		•	•	•		•	•			
Projector lens headlights for extra low beam depth & reduced flare					•				•			•	•	•
Front fog lights					•				•			•	•	•
Chrome radiator grille					•				•			•	•	•
Gun Metal Grey radiator grille	•	•	•	•			•	•		•	•			
Black front bumper and radiator grille						•								
Colour-coded front bumper	•	•	•	•	•		•	•	•	•	•	•	•	•
Rear step bumper bar (Chrome)						•			•					•
Rear step bumper bar (Black)												•		
Space cab rear "wing" doors									•	•				
Aluminium side steps					•				•					•
Black door handles	•	•	•	•		•	•	•		•	•	•	•	•
Chrome door and tailgate handles					•				•					•
Lockable tailgate					•				•					•
Chrome fold-in power door mirrors with integrated turn indicators					•				•					•
Colour-coded power door mirrors with integrated turn indicators	•	•	•	•			•	•		•	•	•	•	•
Black door mirrors						•								
Centre front roof-mounted bee-sting aerial			•	•	•			•	•	•	•	•	•	•
LED rear combination lamps					•				•			•	•	•
One-step chrome-plated rear bumper					•				•					•
<b>Cabin Amenities</b>														
Air-conditioning with integrated heater/windscreen demister	•	•	•	•	•	•	•	•	•	•	•	•	•	•
Pollen & fine particle air filter	•	•	•	•	•	•	•	•	•	•	•	•	•	•
Power windows with one-touch down driver's window	•	•	•	•			•	•		•	•			
Power windows with one-touch up/down driver's window with safety stop and delay closing					•				•			•	•	•
Central locking with keyless entry	•	•	•	•	•		•	•	•	•	•	•	•	•
Power-adjustable door mirrors with turn indicator lights	•	•	•	•	•		•	•	•	•	•	•	•	•
Cruise control	•	•	•	•	•		•	•	•	•	•	•	•	•
"Sky Sound" roof-mounted sound system with 6 speakers (mounted in front dash, front doors and roof)					•				•			•	•	•
CD/MP3/FM/AM/AUX audio unit with Micro USB, iPod® input & Bluetooth® audio streaming			•	•	•				•			•	•	•
CD/MP3/FM/AM/AUX 4 speaker audio unit with Micro USB, iPod® input & Bluetooth® audio streaming	•	•				•	•					•	•	•
Tilt-adjustable steering wheel with power steering	•	•	•	•	•	•	•	•	•	•	•	•	•	•
Leather steering wheel with cruise and audio controls	•	•	•	•	•		•	•	•	•	•	•	•	•
Leather steering wheel with audio controls						•								
Multi-Information Display (MID): odometer, trip odometers A & B	•	•	•	•		•	•	•		•	•			
Multi-Information Display (MID): as above plus fuel economy, range and maintenance distance					•				•			•	•	•
Electro-luminescent gauges					•				•			•	•	•
"Terrain Command" 4WD select dial						•	•	•	•	•	•	•	•	•
Windscreen wipers with intermittent sweep mode	•	•	•	•		•	•	•		•	•			
Windscreen wipers with variable intermittent sweep mode					•				•			•	•	•
Day/night interior rear view mirror	•	•	•	•	•	•	•	•	•	•	•	•	•	•
Sun visors with vanity mirror (left) & ticket retaining strap (right)					•				•			•	•	•
Fixed A-pillar assist-grips for driver and front passenger		•			•	•	•	•	•	•	•	•	•	•
Folding assist-grips for driver and front passenger	•	•	•	•	•	•	•	•	•	•	•	•	•	•
Folding assist-grips for rear passengers			•	•	•					•	•	•	•	•
Carpet flooring					•				•					•
Easy-clean vinyl flooring	•	•	•	•		•	•	•		•	•	•		

# ISUZU D-MAX | FEATURES & SPECIFICATIONS

SPECIFICATIONS	<div style="display: flex; justify-content: space-between; text-align: center;"> <span>4x2 Single Cab Chassis Low-Ride</span> <span>4x2 Single Cab Chassis High-Ride</span> <span>4x2 Crew Cab Ute Low-Ride</span> <span>4x2 Crew Cab Ute High-Ride</span> <span>4x4 Single Cab Chassis</span> <span>4x4 Single Cab Chassis</span> <span>4x4 Space Cab Chassis</span> <span>4x4 Space Cab Ute</span> <span>4x4 Crew Cab Chassis</span> <span>4x4 Crew Cab Ute</span> <span>4x4 Crew Cab Ute</span> <span>4x4 Crew Cab Ute</span> </div>													
	SX	SX	SX	SX	LS-U	EX	SX	SX	LS-U	SX	SX	LS-M	LS-U	
<b>D-MAX ADR 81/02<sup>2</sup> Fuel Consumption Values</b>														
Transmission (MT = Manual, AT = Automatic)	MT	AT	MT	AT	MT / AT	MT	MT / AT	MT / AT	MT / AT	MT / AT	MT / AT	MT / AT	MT / AT	MT / AT
<b>FUEL CONSUMPTION (litres/100km)</b>														
Urban	10.7	10.5	10.8	10.5	11.0/10.9	11.0	11.0/10.9	11.0/10.9	11.0/10.9	11.0/10.9	11.0/10.9	11.0/10.9	11.0/10.9	11.0/10.9
Extra Urban	6.7	7.0	6.9	7.0	7.0/7.3	7.0	7.0/7.3	7.0/7.3	7.0/7.3	7.0/7.3	7.0/7.3	7.0/7.3	7.0/7.3	7.0/7.3
Combined	8.2	8.3	8.3	8.3	8.5/8.6	8.5	8.5/8.6	8.5/8.6	8.5/8.6	8.5/8.6	8.5/8.6	8.5/8.6	8.5/8.6	8.5/8.6
<b>CO<sup>2</sup> (g/km)</b>														
Urban	281	277	284	277	289/287	289	289/287	289/287	289/287	289/287	289/287	289/287	289/287	289/287
Extra Urban	177	185	183	185	186/192	186	186/192	186/192	186/192	186/192	186/192	186/192	186/192	186/192
Combined	215	219	220	219	224/227	224	224/227	224/227	224/227	224/227	224/227	224/227	224/227	224/227
<b>Dimensions (mm unless stated otherwise)</b>														
Wheelbase	3095	3095	3095	3095	3095	3095	3095	3095	3095	3095	3095	3095	3095	3095
Overall length	5040	5040	5190	5190	5295	5040	5040	5020	5295	5020	5190	5295	5295	5295
Overall width (excluding door mirrors)	1775	1860	1775	1860	1860	1860	1860	1860	1860	1860	1860	1860	1860	1860
Overall height (*depends on body fitted)	1685*	1780*	1690	1785	1795	1780*	1780*	1780*	1790	1785*	1785	1785	1795	1795
Front overhang	905	905	905	905	905	905	905	905	905	905	905	905	905	905
Rear overhang (*depends on body fitted)	1040*	1040*	1190	1190	1295	1040*	1040*	1020*	1295	1020*	1190	1295	1295	1295
Front and rear track	1510	1570	1510	1570	1570	1570	1570	1570	1570	1570	1570	1570	1570	1570
Ground clearance	190	225	190	225	235	225	225	225	235	225	225	225	235	235
Turning circle diameter between kerbs (metres)	12.0	12.6	12.0	12.6	12.6	12.6	12.6	12.6	12.6	12.6	12.6	12.6	12.6	12.6
Approach angle	20.7°	29.4°	20.7°	29.4°	30°	29.4°	29.4°	29.4°	30°	29.4°	29.4°	30°	30°	30°
Departure angle	20.3°	27.4°	20.3°	27.4°	22.7°	27.4°	27.4°	27.4°	22.7°	27.4°	27.4°	22.7°	22.7°	22.7°
Ramp-over angle	17.3°	21.7°	17.3°	21.7°	22.4°	21.7°	21.7°	21.7°	22.4°	21.7°	21.7°	22.4°	22.4°	22.4°
<b>Load area (mm)</b>														
Cab to rear axle	1235	1235	430	430	430	1235	1235	740	740	430	430	430	430	430
Length (top)	-	-	1485	1485	1485	-	-	-	1795	-	1485	1485	1485	1485
Length (floor) (*inside genuine accessory tray body)	2550*	2550*	1552	1552	1552	2550*	2550*	1950*	1825	1650*	1552	1552	1552	1552
Maximum width (*inside genuine accessory alloy tray body)	1778*	1778*	1530	1530	1530	1778*	1778*	1778*	1530	1778*	1530	1530	1530	1530
Width between wheel houses	-	-	1105	1105	1105	-	-	-	1105	-	1105	1105	1105	1105
Depth	-	-	465	465	465	-	-	-	465	-	465	465	465	465
<b>Interior (mm)</b>														
Leg room - front	1070	1070	1070	1070	1070	1070	1070	1070	1070	1070	1070	1070	1070	1070
Leg room - rear	-	-	915	915	915	-	-	740	740	915	915	915	915	915
Shoulder room - front	1460	1460	1460	1460	1460	1460	1460	1460	1460	1460	1460	1460	1460	1460
Head room - front	1005	1005	1005	1005	1005	1005	1005	1005	1005	1005	1005	1005	1005	1005
<b>Mass (kg)</b>														
Tare mass* (*depends on body fitted) (* +10kg for automatic on 4x2; +5kg for automatic on 4x4)	1530*	1585*	1770	1820	1835*	1660*	1665**	1745**	1905*	1815**	1925*	1925*	1940*	1940*
Total load capacity (*depends on body fitted) (* -10kg for automatic on 4x2; -5kg for automatic on 4x4)	1320*	1265*	1080	1030	1015*	1290*	1285**	1205**	1045*	1135**	1025*	1025*	1010*	1010*
Gross Vehicle Mass (GVM)	2850	2850	2850	2850	2850	2950	2950	2950	2950	2950	2950	2950	2950	2950
Gross Combination Mass (GCM)	5350	5350	5350	5350	5350	5950	5950	5950	5950	5950	5950	5950	5950	5950
Maximum towing mass (braked trailer)	2500	2500	2500	2500	2500	3500	3500	3500	3500	3500	3500	3500	3500	3500
Maximum towing mass (non-braked trailer)	750	750	750	750	750	750	750	750	750	750	750	750	750	750
Maximum tow ball download (when fitted with genuine Isuzu UTE tow kit)	250	250	250	250	250	350	350	350	350	350	350	350	350	350
Fuel tank capacity (litres)	76	76	76	76	76	76	76	76	76	76	76	76	76	76

<sup>2</sup>ADR 81/02 is the Australian government's standard lab-based test. Your fuel figures depend on driving style, conditions of usage, vehicle condition and load, and other factors.  
 iPod® is a trademark of Apple Inc. The Bluetooth® word mark is owned by Bluetooth SIG, Inc. Not all devices will be compatible and functionality will vary depending on the device.  
 \*Tare Mass - unladen mass of vehicle and 10 litres of fuel; excludes tray body for cab chassis vehicles.

## 4x4 LS-U Crew Cab Ute & 4x2 LS-U Crew Cab Ute High-Ride

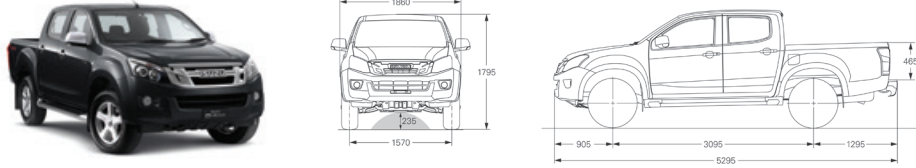

## 4x4 LS-U Space Cab Ute

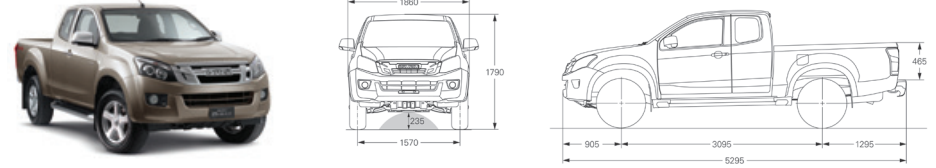

## 4x4 LS-M Crew Cab Ute

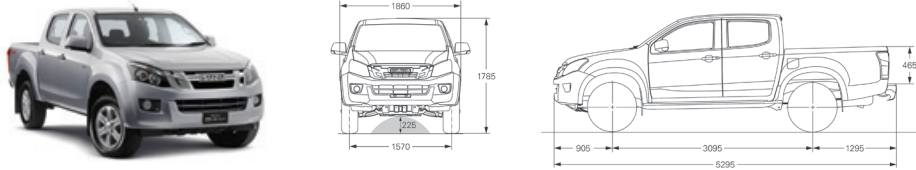

## 4x4 SX Space Cab Chassis

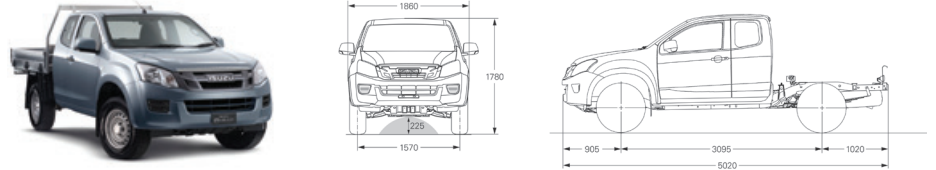

## 4x4 SX Crew Cab Ute & 4x2 SX Crew Cab Ute High-Ride

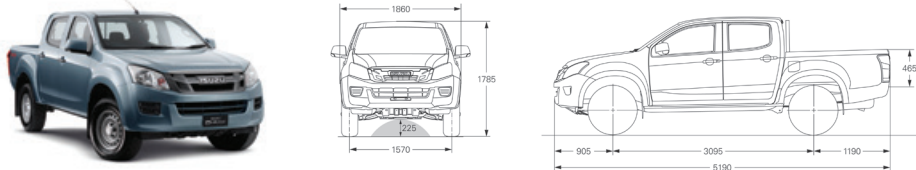

## 4x4 SX Single Cab Chassis & 4x2 SX Single Cab Chassis High-Ride

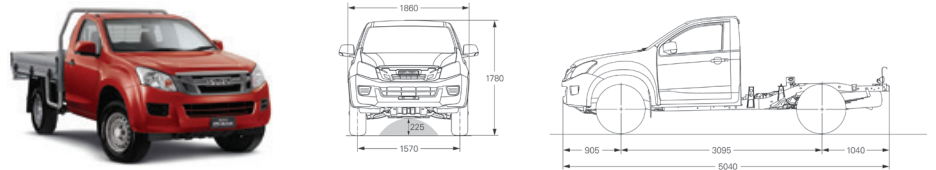

## 4x4 SX Crew Cab Chassis

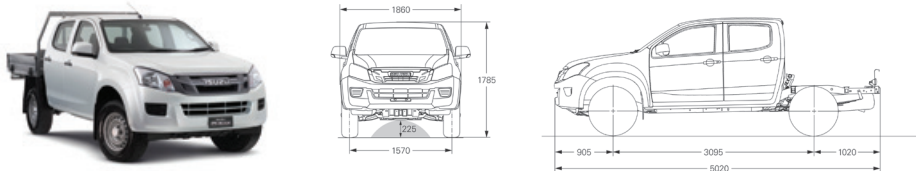

## 4x4 EX Single Cab Chassis

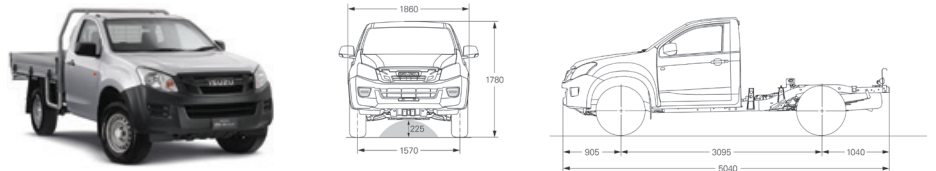

## 4x2 SX Crew Cab Ute Low-Ride

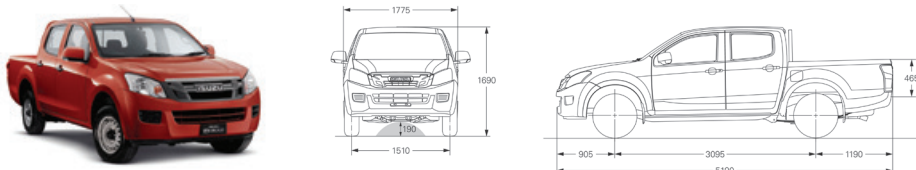

## 4x2 SX Single Cab Chassis

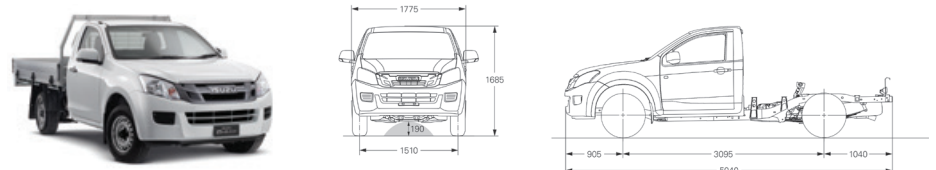

## Colour Options



Ash Beige metallic



Cosmic Black mica



Mineral Grey metallic



Nautilus Blue mica



Splash White



Titanium Silver metallic



Tundra Green mica



Venetian Red mica