

ISUZU  
TRUCKS  
CELEBRATING  
**25**  
YEARS LEADERSHIP  
1989 - 2013

We  
share  
the  
load.

**ISUZU**  
RELIABILITY IS EVERYTHING

## FY SERIES

GVM: 30,000 – 35,000KG GCM: 42,500KG



EFFECTIVE  
MAR 2014

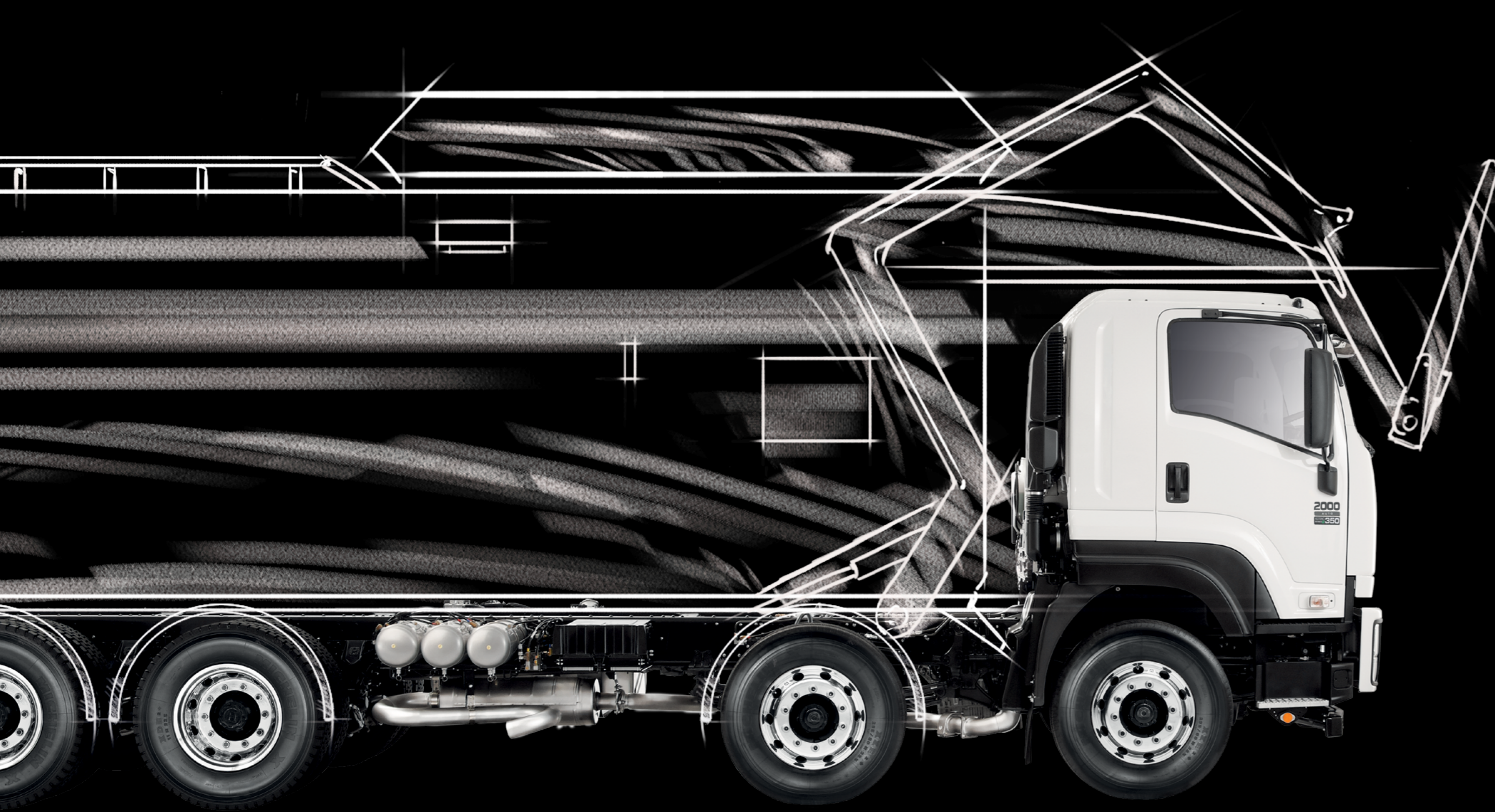

# WE SHARE THE LOAD. SO DOES THE TWIN AXLE.

**ISUZU HAS BEEN THE LEADING TRUCK BRAND IN AUSTRALIA FOR 25 YEARS STRAIGHT\*. A DOMINANT POSITION EARNED BY OFFERING YOU SAFETY, PERFORMANCE, DRIVEABILITY, COMFORT, OPERATING COSTS, PRODUCTIVITY AND, ABOVE ALL, OUR LEGENDARY RELIABILITY. THE FY SERIES, WHAT'S MORE, GIVES YOU A BIG EXTRA: ANOTHER STEER AXLE. IT COMES IN 8X4 AND 10X4 CONFIGURATIONS, WITH THREE MODELS AND NINE VARIANTS. YOU ALSO HAVE CHOICES OF TRANSMISSIONS, WHEELBASES, AXLES AND SUSPENSIONS. AND, DEPENDING ON THE TYPE OF BODY YOU HAVE FITTED, THE FY SERIES IS JUST AS EFFICIENT AT CRANING BRICKS AS CRUSHING GARBAGE. ALL OF WHICH WILL HELP MAKE YOUR DAILY GRIND MUCH LESS OF A GRIND, WHATEVER YOUR APPLICATION. AND BY CONTINUING TO SHARE THE LOAD WITH YOU WE HOPE TO NEVER SHARE THE LEAD WITH ANYONE.**

\*According to T-Mark industry statistics.

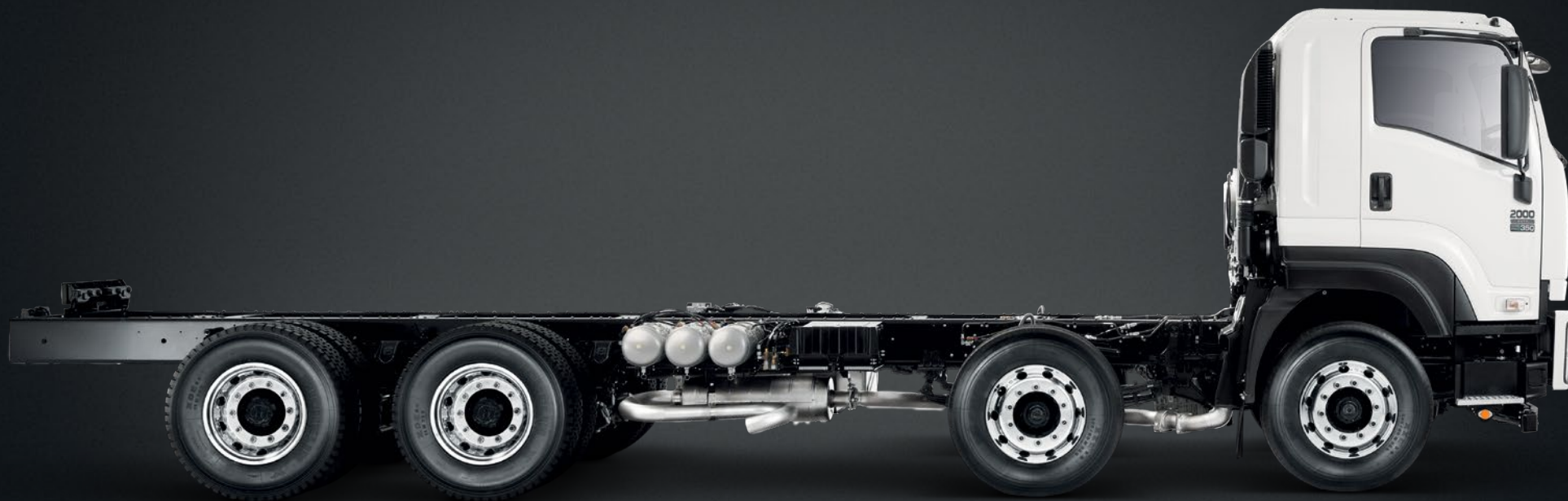

# 8X4

**THERE ARE TWO 8X4s, THE FYJ 2000 AND FYH 2000, EACH COME FOUR WAYS. AS YOU'D EXPECT FROM ISUZU, THEY'RE SUPERBLY ENGINEERED, EQUIPPED FOR INSTANCE WITH AN ALLISON 4430 IN THE AUTO MODELS, WHERE A 3200 IS THE INDUSTRY NORM. WE NEVER SKIMP.**

- Isuzu SITEC III 350 diesel engine.
- ZF 9-speed and Eaton 10-speed manuals.
- Allison 4430 auto.
- Long and extra-long wheelbases.
- Hendrickson airbag and Isuzu 6-rod suspensions.
- Meritor front and rear axles.
- First-class cabs come standard with three seats.
- ISRI 6860 air-suspension driver's seat.
- Integrated air-conditioning.
- DAVE infotainment system, with digital radio, DVD, MP3, voice-control and Bluetooth.

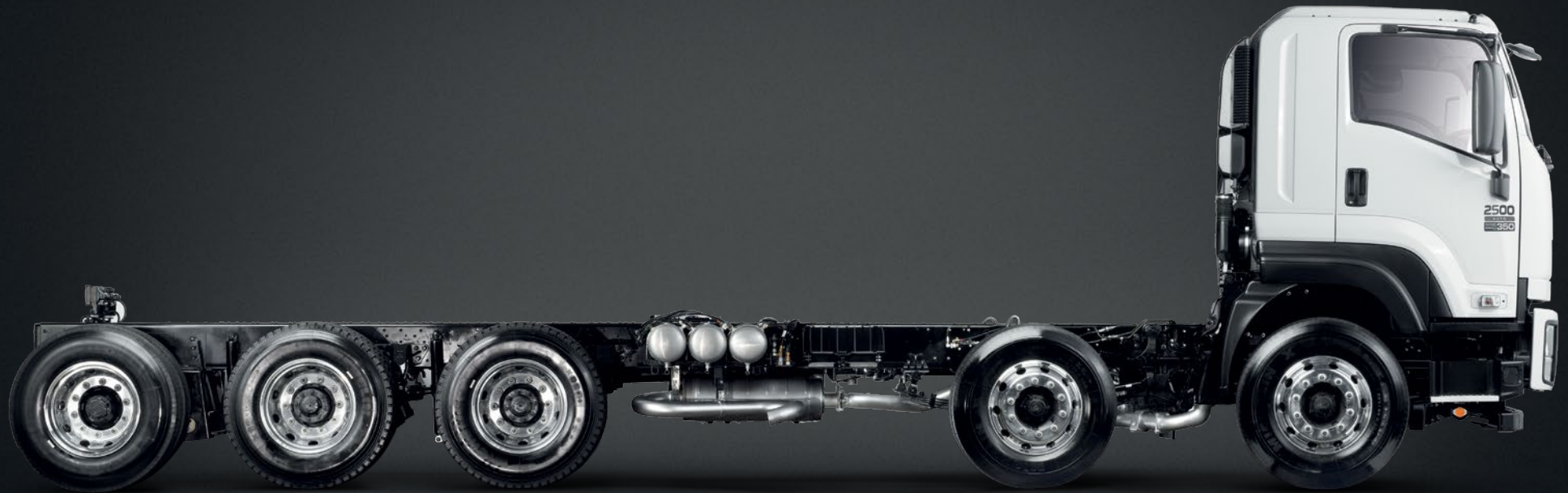

# 10X4

**THE FYX 2500 IS AUTO ONLY, AGAIN BOASTING THE SUPREME ALLISON 4430 (WHERE OTHERS WOULD'VE SETTLED FOR A SMALLER VERSION). WHILE THE REAR END COMBINES THE VERY BEST OF AMERICAN COMPONENTRY, FROM MERITOR AND HENDRICKSON.**

- Isuzu SITEC III 350 diesel engine.
- Allison 4430 auto transmission.
- Hendrickson airbag / HLM suspension.
- Meritor front axles / Hendrickson rear lift axle.
- First-class cabs come standard with three seats.
- ISRI 6860 air-suspension driver's seat.
- Integrated air-conditioning.
- DAVE infotainment system, with digital radio, DVD, MP3, voice-control and Bluetooth.

## FOUR FRONT WHEELS. IT'S A STEERING COMMITTEE.

The FY's load-sharing twin-steer front axle can really broaden your horizons. You see, it's ideal for all sorts of heavy-duty applications, from tipping to tilting. Simply because it boosts your GVM by a tonne and spreads it evenly across your wheelbase. (We share your load; so does it). The front end also features a unique dampener system to give you a better ride and the chassis an easier day.



## THE BEST SEAT IN THE BUSINESS.

All FY Series have the ISRI 6860 air-suspension driver's seat as standard. And it's anything but standard. It incorporates a lap-sash seatbelt, head restraint, dual-stage air lumbar/lateral support, integrated pneumatic system, adjustable shock-absorber and body-hugging upholstery from head to knee. Sharing the load for the sake of your body.



## CONVENIENCE THAT CLICKS.

As you've read, we've made our cabs easy and safe to get in and out of. Remote, keyless entry and locking make it convenient as well. And if you're in and out of your truck all day long, it's a feature you'll really appreciate.

\*Remote shown is for illustrative purposes only.

## CARRY LOADS IN THE CAB.

Cabs are anything but afterthoughts with Isuzu. For instance, you'll find stacks of storage space and locations for all your stuff. Along with heaps of room for you and your workmates as well, including generous stretch-out legroom. All in all, it's a very comfy and accommodating place to be.



## MEET DAVE, YOUR STREET-SMART SIDEKICK.

Our Digital Audio Visual Equipment, the ultimate cab infotainment system, is right at your fingertips. Navigate through the simple menu to play your favourite songs or (digital) station, or, for even greater convenience and safety, use voice-controls for many of the functions available. Hands-free Bluetooth is standard, and sat-nav and tyre-pressure monitoring are optional. You'll never work alone.

## TWIN STEER. DOUBLE COMPLIANCE.

All FYs come pre-fitted with the Front Under-run Protection System (FUPS), complying with the ECE-R93 safety standard. And their strengthened cabs comply with ECE-R29. All helping you to work safe.



# BRICKS, SKIPS OR MILK. FY HAULS IT ALL.

Few other trucks can comfortably fill so many roles. Tilt, lift, skip, tip, mix, chill, pump, crush and more, as you see here. The FY Series wears many, many hats.

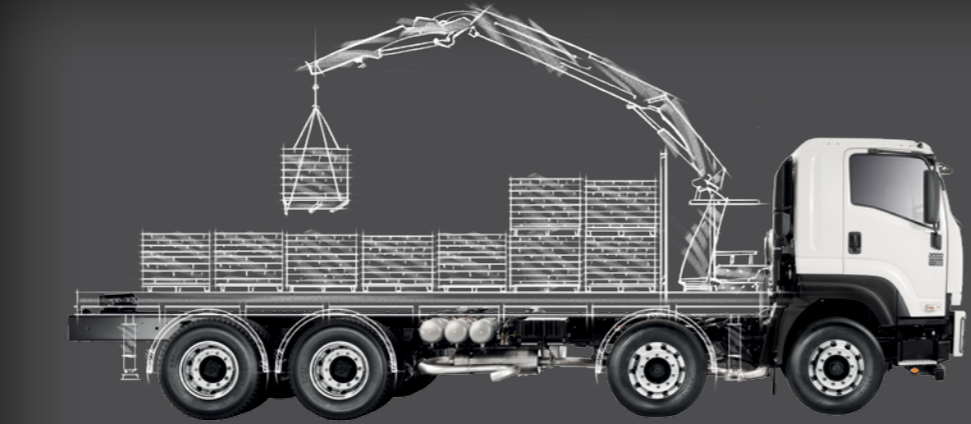

CRANE

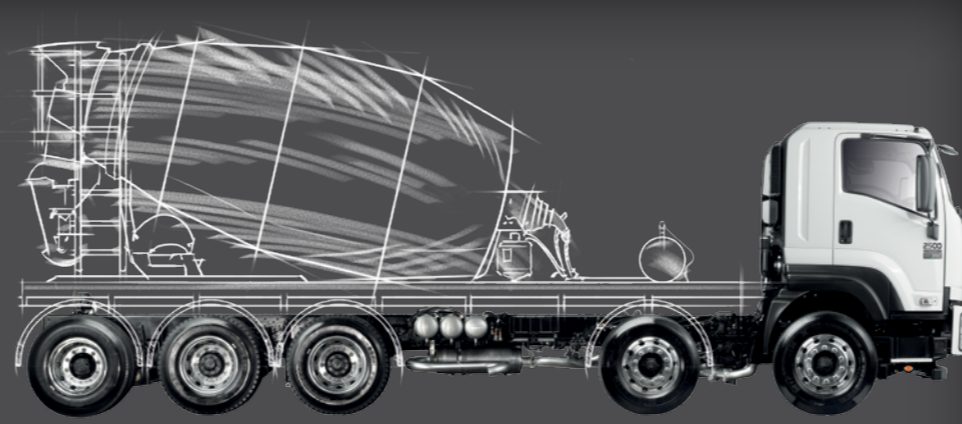

AGITATOR



CONCRETE PUMPER

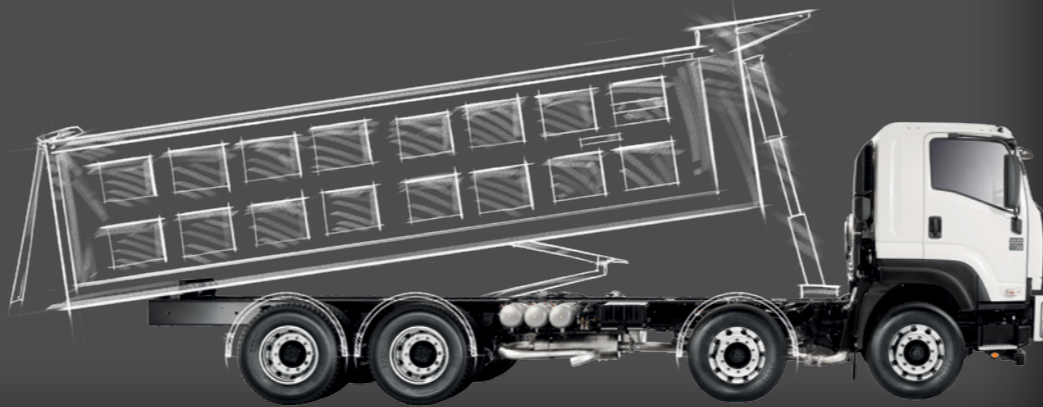

TIPPER

# BRIGHT AND LIGHT.

Isuzu has an 8x4 and 10x4 model that comes standard with aluminium disc wheels. Combined with aluminium fuel tanks and other weight-saving measures, our 8x4 'Agitator spec' comes in at a very respectable tare mass.



# EURO V COMPATIBLE.

To meet tough Euro V environmental standards we have fitted a Diesel Oxidation Catalyst (DOC) and an Exhaust Gas Recirculation system (EGR). The DOC offers greater simplicity for body builders and operators, while the EGR not only reduces harmful emissions, but also delivers improved driveability and enhanced engine braking.

Most of all, no particulate filter or the need for AdBlue, so all you need to do is fill it with diesel and drive.



# SELECT YOUR GEAR.

The FY offers you three tried-and-tested transmissions. The trusty German ZF 9-speed and rugged American Eaton 10-speed manuals. And the mighty Allison HD 4430 6-speed auto, also from America. What a choice it is.



# NEVER GET STUCK.

Our factory-fitted cross locks mean you'll never again get hung-up on rough or uneven surfaces. Simply flick a switch to engage all your driving wheels and get power firmly to the ground. No stopping you.

MODEL	DESIGNATION	GVM (kg)	GCM (kg)	ENGINE	POWER (kW@RPM)	TORQUE (Nm@RPM)	TRANSMISSION (GEARS/TYPE)	REAR AXLE	REAR SUSPENSION
FYJ 2000 8x4	PTO	30,000	42,500	SITEC III 350	257 @ 2,000	1,422 @ 1,400	Eaton 10	Meritor RT40-145	HAS 461 Air
	AUTO						Allison 4430 automatic		
	LONG / X-LONG						ZF 9-speed manual		
FYH 2000 8x4	PTO / AUTO	30,000	42,500	SITEC III 350	257 @ 2,000	1,422 @ 1,400	Eaton 10	Meritor RT40-145	Isuzu 6-rod
	LONG PTO / LONG AUTO						Allison HD 4430		
FYX 2500 10x4	AUTO	35,000	42,500	SITEC III 350	257 @ 2,000	1,422 @ 1,400	Allison 4430 automatic	Meritor RT40-145 + Hendrickson D22	HAS 461 Air + HLM2

# WARRANTIES<sup>†</sup>

MODEL	VEHICLE	ENGINE	CABIN PERFORATION CORROSION	EXTENDED CARE WARRANTY*
All FY models	3 years or 250,000 kilometres or 4,000 hours		3 years unlimited kilometres	Refer to your Isuzu Dealer

<sup>†</sup>From delivery. \*Extended Warranty available at extra cost. Conditions apply. Note: The above chart is a brief representation of the chassis specifications within the Isuzu FY Series model range. For a detailed understanding of the model and specification variants, please refer to the applicable Isuzu model Specification Sheet. Subject to the conditions outlined in the IAL New Vehicle Warranty, the FY Series models carry a standard factory warranty as above. Extended Warranty may be purchased to cover the owner against the failure of original components, but may exclude some components and expendable items such as oil, filters etc. Isuzu Roadside Assistance is valid for three years from the date of new vehicle purchases. All Isuzu warranties are subject to mandatory prescribed terms under Australian Consumer law including customer guarantees. For more details visit the Isuzu website which explains Isuzu Warranties in more detail, or alternatively contact your local dealer. All warranties commence from date of delivery.

# ISUZU CARE.

Reliability means so much more than just a mechanically reliable truck. Isuzu Care is the most comprehensive customer care truck programme ever seen in Australia, offering a suite of innovative support services and a level of customer care that's setting new industry standards. Wherever you may be, Care's as close as Freecall 1800 035 640.



## THE CONNECTED TRUCK.

Isuzu 'Connect' telematics interconnects both truck and driver with your full support team, from the dispatcher to the service manager. To electronically, automatically and continuously share countless data, in real time, on virtually everything the truck and the driver do. From its brakes to his breaks. From how long it spent idling to where it spent the night. And in the process, makes all of you even better 'drivers', including the driver himself.



## ISUZU ROADSIDE ASSIST.

Isuzu Assist is a 3-year, 24-hour roadside assistance program that comes at no extra cost with all new Isuzu Trucks. And while our trucks are renowned for their reliability, even if you run out of fuel, lose your keys, get a flat tyre (or battery), Isuzu Assist will be there to sort it out. Just Freecall 1800 947 898.



## ISUZU SERVICE AGREEMENTS.

Truck maintenance costs can be unpredictable. However, Isuzu Service Agreements level out the costs of operating your Isuzu Truck. For one fixed monthly fee your truck is serviced to precise specifications by Isuzu technicians using high-tech diagnostic equipment and genuine Isuzu parts. And you can choose from a fixed-price Scheduled Services Plan right through to a comprehensive Total Repair and Maintenance Plan.

## ISIS.

Isuzu Sales Information System (ISIS for short) is a software program the dealer will use to help you select the right truck and body for your application. Once it's been programmed with your information, ISIS simulates how the truck will perform in terms of its weight distribution, available power and other performance characteristics. So with ISIS, you're sure to find your perfect match.

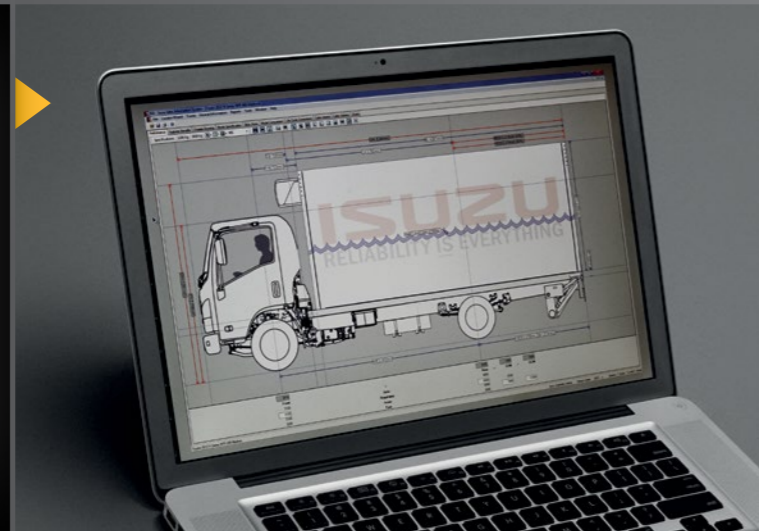

## ISUZU EXTENDED CARE.

Isuzu Extended Care\* provides a two-year extension to Isuzu's three-year factory warranty. As well as the five-year factory warranty, you'll also receive five years of Isuzu's Customer Care programme and Isuzu Assist. Available when you buy your truck, it's the ultimate peace-of-mind.

\*At additional cost



## ISUZU TRUCK INSURANCE.

By joining forces with Australia's leading truck insurance specialist, NTI, Isuzu can now offer you access to a broad range of insurance products designed specifically for the transport industry, including Commercial Motor Policy, Public & Products Liability Policy, Marine Cargo Policy to cover the freight liability and carriers' cargo insurance, and Business Interruption Policy.





**We  
share  
the  
load.**

**ISUZU**  
RELIABILITY IS EVERYTHING

[isuzu.com.au](http://isuzu.com.au)

TIC: Isuzu is a member of the Truck Industry Council – *Safer Greener Essential*. Isuzu Australia Limited ABN 97 006 962 572 ("IAL"). The information in this brochure was correct at time of printing, but all measurements, specifications and equipment are subject to change without notice. Some equipment may have been changed and/or is available at extra cost. IAL may make changes at any time without notice, in prices, colours, materials, equipment and models. IAL makes all reasonable attempts to ensure the availability of all vehicles and equipment. The information in this brochure is general in nature. Your Isuzu Truck Dealer can confirm all measurements, specifications and vehicle/equipment availability upon request. Any body illustrated is not standard equipment. MAR2014 F•S•A/ISZ9021